

F9J GCB B

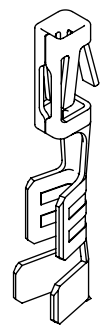

CNN'FO GP URQP U'CTG'TGHGTGP EGU  
 \*UGG'ZE/39;/ZZ/Z/ZZ'HQT'EQP VTQNNR I 'RTR' V+'

77 +-L!LLLL!LLL!  
 G DD@98  
 I@ @C C G9  
 IF. F99@  
 D@5 HB:  
 I: : @5G: G9@97 HJ 9  
 I@ @: <H9@97 HJ 9  
 I G G9@97 HJ 9  
 @958 GHM@  
 !&\* \$ R&'! \$ 5K ; E  
 !&\$&( T&S!& ( 5K ; E  
 H !& ' \$ R&'! \$ 5K ; E TDH 9E  
 C DHC B  
 RIB G @5HC B H: -7 ? B 9GGE  
 I \$%



H'BC HF9@95 G98 : C F DFC 81 7 HC B

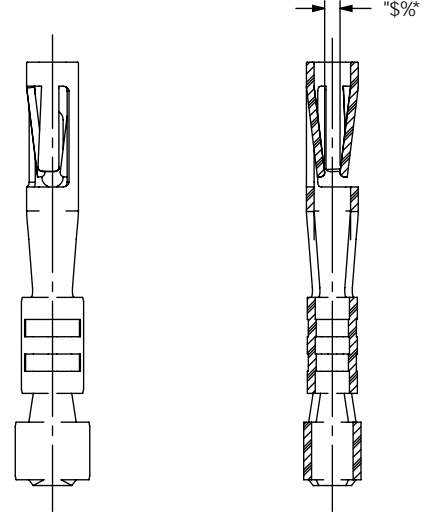
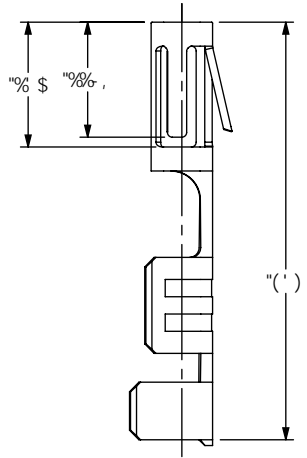
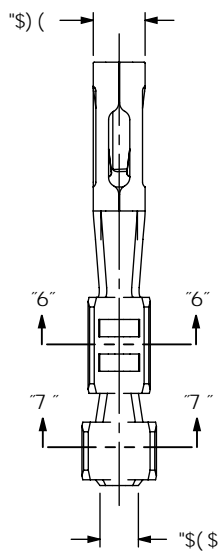
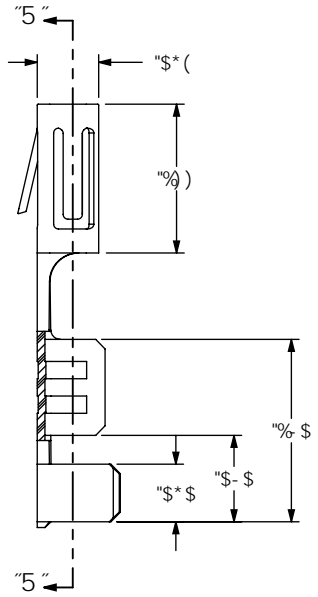

G97 HC B "5" "5"

: = "%

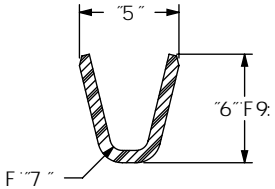

G97 HC B "6" "6"

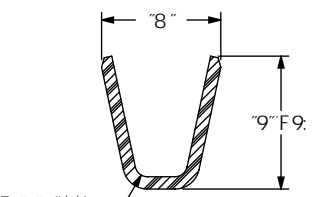

G97 HC B "7" "7"

TABLE 1

STYLE	"A"	"B" REF	"C"	"D"	"E" REF	"F"	"J"	"K"
-2630	.055	.045	.015	.080	.073	.025	.010	.020
-2024	.080	.073	.018	.110	.103	.030	.010	.030
*-2830	.055	.045	.015	.054	.057	.016	.010	.020

I'BC HHC @98

I B @9G C H: 9FK @9 : G97 = 982 8 A 9B GC BG 5F9 B B7 < 9G HC @9F 5B 7 9G 5F9. 897 A 5 @G ..... 5B; @9G "LLL" ..... & * "LLL" ..... "LLLL" .....	DFC DF 9H5 FMBC H@ H: 68C 71 A 9B H7 C B15 8G B: CFA 5HC B 7 C B: 89B H5 @5B 8 DFC DF 9H5 FMBC G5A H7 Z B7 * 5B 8 G: 5 @B C H69 F 90FC 81 7 98 C F H5BG 9F 98 HC C H: 9F 8C 71 A 9B HG C F 8 47 @C 98 HC C H: 9F GC F I 98 : C F 5BM DI FDC 9C H: 9F H: 5B H: 5HK < 7 < H: 5G C 6H5 898 K H: C I H: 9 9L DF 9G98 K F H98 7 C B 98 HC : G5A H7 Z B7 *	) & \$ D5 F? 95 GH6 @ 82 B 9K 5 @5 B M B (+) \$ D < C B 9 ; %& L - ((! * + ..... 5L ; %& L - ( ) ) \$ (+ YIA UJ ; ) & z 4 G5A H7 Wc a ..... Wc XY.) ) & &
A 5H F 5 @ ..... 8 C ' B C H G 7 5 @9 8 F 5 K B : ..... G: 99 H G 7 5 @9 ) . % D < C G 6 F C B N 92 ) % \$ G D F B : H 9A D 9 F H: - 7 ? B 9 G G " \$ \$ , \$	8 9 G 7 F @ H C B : ..... "% \$ \$ - D 8 % 7 C B H 5 7 H 8 K : " B C " ..... 7 7 +- L ! L L L L ! L L L !	6 M 8 9 5 B D , # / & # & \$ \$ ( ..... G < 9 9 H % C : &

: .P8K : PA 47 PA 7H P77 +-L!LLLL!LLL!IA ?HG@88FK

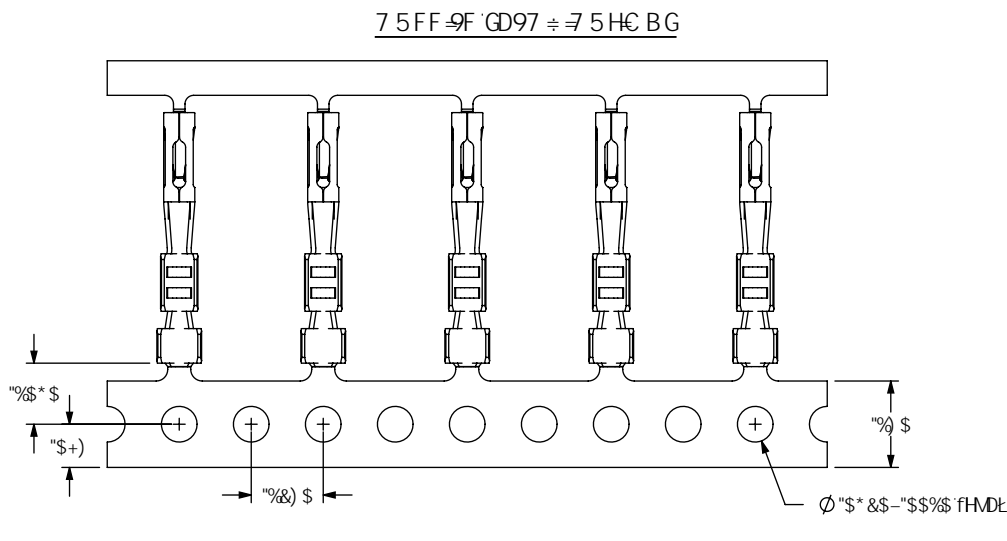

F 99@GD97 ≈ 7 5H€ BG

D@5H8 7 !%+- D5FHGHC '69DI @98ZD@5H9C DHC B 7 C B: #A 98Z7 CFF97 H85G<  
BI A 69F 7 C B: #A 98 '6M7 < 97 ? B: "9F9: "8 A 9BGC BZ  
I BK C I B8ZHK 9B F9K C I B8 5B8 7 C I BH8Z  
% Z\$S\$Z' \$S\$# 'D7 GDC G#C B98 5GG<CK B C B G5A H97 F99@K #k J 9K DC FHGZ  
@5 69@98 7 7 +- K #k 5DDFC DF 5H9D@5H97 5@CC I H5B8' @5 69@D@5 7 98 5GG<CK B"  
A 5L A I A Bc C: 'GD@7 9GD9F F99@&" GD@7 9G5F9BC HHC '697 CBB97 H98"  
BI A 69F C: 'GD@7 9GHC '69A 5F?98 C B 957 < F99@  
F99@8 'D5FHGHC '69 BHPF @95J 98 K #k D5D9F '69H 99B 957 < @M9F C: 'D5FHG'  
'C B9 GD@7 9 B -BHPF @95: 5@CC K 98 D9F F99@ G97 I F9@M7 C BB97 H BHPF @95: 'GD@7 9'  
C I HPF K F5D G< 5@@F 97 9J 9F6I& (! \$+) !D DFC H97 HJ 9F99@65B8"

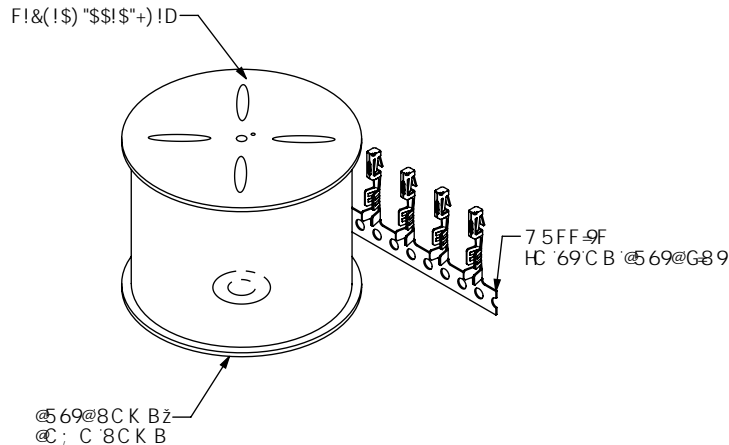

I BK B8B; '8F97 H€ B

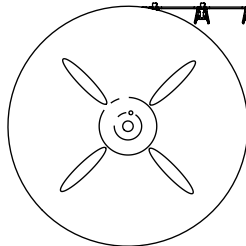

: P8K : PA 67 PA 7H P77 +-LILLILLILLIA ?HG@8FK

DFC.DF-9F5FMBCI9  
H:GBC71A 98H7C B16BG B:CFA 5HC B  
7C B: @98H@5B8 DFCDF 945F HMC  
GSA H97Z 87"5B8 G-5@9BC H69F9FC 81 798  
CF HF5BG 9F98 HC C H: 9F 8C71A 98H6CF  
8 47 @C98 HC C H: 9FGCF I 98: C F 58M  
DI FDC @9CH: 9F H: 5B H: 5HK < ? < #K 5G  
C 616 B 98 K #k C I H H: 99L DF 9098 K F #H8  
7 C B 98HC: G5A H97 Z 87"

8C 'BCH G7 5@ 8F5K B:

G: 99HG7 5@ 9) %:

) &\$ D5F? 95GH6@ 8ZB9K 5@5BM B ( + ) \$ D < C B 9 ; %&L - ( ( ! * + ) ) : ; S L ; %&L - ( , ) \$ ( + YIA UJ ; J Z: 4 G5A H97 Wc a ..... Wc X Y ) ) ' &&	
89G7 F@HC B. "%\$\$ -D8% 7 C B H 57 H	
8K : "BC" 77 +- LILLILLILLI!	
6M 895 B D , #/ & # & \$ \$ (	G< 99H & C : &

# Mouser Electronics

Authorized Distributor

Click to View Pricing, Inventory, Delivery & Lifecycle Information:

[Samtec:](#)

[CC79L-2830-01-S](#)