

DIMENSIONS ARE IN INCHES UNLESS OTHERWISE NOTED TOLERANCES ARE:
 ONE PLACE DECIMALS ±.1[2.5] THREE PLACE DECIMALS ± .005 [.13]
 TWO PLACE DECIMALS ±.01[.25] FOUR PLACE DECIMALS ±.0020[.05]
 ANGLES ± 2°

TITLE: 2mm
 TERMINAL STRIP
 ASSEMBLY

DWG NO: MTMM-1XX-XX-XX-X-XXX-XX-XXX
 SHEET 1 OF 2

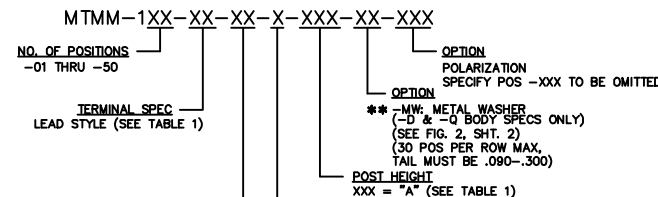
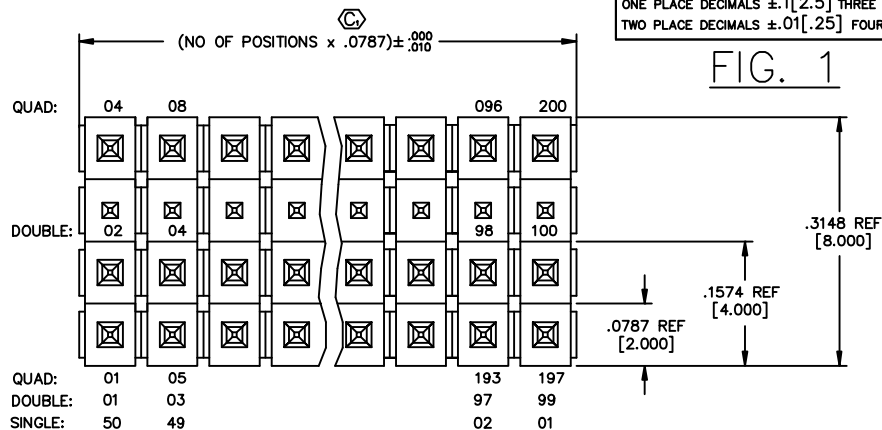

- PLATING SPECIFICATION
 -G: GOLD (USE T-1S13-XX-G-2)
 -T: TIN (USE T-1S13-XX-T-2)
 -S: HEAVY SELECTIVE GOLD (USE T-1S13-XX-S-2)
 -L: LIGHT SELECTIVE GOLD (USE T-1S13-XX-L-2)
 -F: FLASH SELECTIVE GOLD (USE T-1S13-XX-F-2)
 -H: HEAVY GOLD (USE T-1S13-XX-H-2)
 -SM: HEAVY GOLD SELECTIVE, MATTE TIN TAIL (USE T-1S13-XX-S-2)
 -TM: MATTE TIN (USE T-1S13-XX-T-2)
 -LM: LIGHT GOLD SELECTIVE, MATTE TIN TAIL (USE T-1S13-XX-L-2)
 -FM: FLASH GOLD SELECTIVE, MATTE TIN TAIL (USE T-1S13-XX-F-2)

**** - MW OPTION, DO NOT DESIGN IN. SAMTEC WILL ONLY SUPPORT EXISTING BUSINESS 2/08/02.**

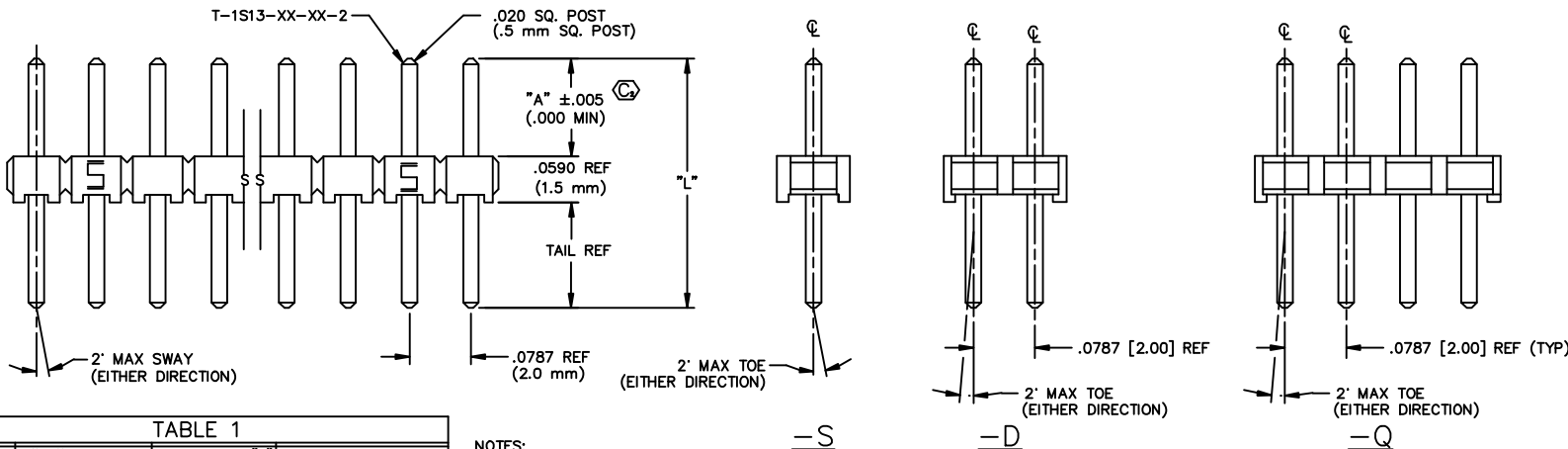

| LEAD STYLE | "A" MAX. | PIN LENGTH "L" | TERMINAL |
|------------|---------------|----------------|----------------|
| -02 | .1960 [4.98] | .255 [6.48] | T-1S13-04-XX-2 |
| -03 | .2430 [6.17] | .302 [7.67] | T-1S13-07-XX-2 |
| -04 | .2640 [6.71] | .323 [8.20] | T-1S13-20-XX-2 |
| -05 | .3180 [8.08] | .377 [9.58] | T-1S13-02-XX-2 |
| -06 | .3380 [8.59] | .397 [10.08] | T-1S13-05-XX-2 |
| -07 | .3970 [10.08] | .456 [11.58] | T-1S13-13-XX-2 |
| -08 | .4170 [10.59] | .476 [12.09] | T-1S13-08-XX-2 |
| -09 | .4760 [12.09] | .535 [13.59] | T-1S13-03-XX-2 |
| -10 | .4960 [12.60] | .555 [14.10] | T-1S13-06-XX-2 |
| -11 | .5350 [13.59] | .594 [15.09] | T-1S13-09-XX-2 |
| -12 | .5550 [14.10] | .614 [15.60] | T-1S13-14-XX-2 |
| -13 | .6140 [15.60] | .673 [17.09] | T-1S13-10-XX-2 |
| -14 | .6920 [17.58] | .751 [19.07] | T-1S13-11-XX-2 |
| -15 | .7710 [19.58] | .830 [21.08] | T-1S13-12-XX-2 |

- NOTES:
 1. MAX ALLOWABLE BOW: .005 IN/IN AFTER ASSEMBLY.
 2. MAX PIN ROTATION IN BODY: 2°
 3. PUSHOUT FORCE SHALL BE 1 lb MIN.
 4. Ⓢ REPRESENTS A CRITICAL DIMENSION FOR STATISTICAL PROCESS CONTROL USE.
 5. NOTE DELETED
 6. CUT PARTS WITH METAL WASHERS TOWARD OPERATOR ALLOWING FLASH TO BE ON POST AWAY FROM CRITICAL AREA (METAL WASHERS).
 7. ORIENTATE PINS TO LIMIT BANDOLIER MARKS FROM SHOWING IN THE POST AREA. (SEE TABLE 3)

PROPRIETARY NOTE
 THIS DOCUMENT CONTAINS INFORMATION CONFIDENTIAL AND PROPRIETARY TO SAMTEC INC. AND SHALL NOT BE REPRODUCED OR TRANSFERRED TO OTHER DOCUMENTS OR DISCLOSED TO OTHERS OR USED FOR ANY PURPOSE OTHER THAN THAT FOR WHICH IT WAS OBTAINED WITHOUT THE EXPRESSED WRITTEN CONSENT OF SAMTEC INC.

"A" MAX = "L" - .059 (BODY) TAIL CAN BE .000

MATERIAL:
 BODIES: LCP
 COLOR: BLACK
 TERMINALS: PHOSPHOR BRONZE

PLOT SCALE 1=125/ DIMSCALE: 1=100

EXISPROD\ASSEMBLY\2MM
 MTMM-ASM
samtec

520 PARK EAST BLVD. NEW ALBANY, INDIANA 47150
 PHONE (812) 944-6733 P.O. BOX 1147
 CODE 55322

MADE BY: REIDINGER 12-1-93

MTMM-1XX-XX-XX-X-XXX-XX-XXX
 SHEET 1 OF 2

REV. AC

FIG. 2

DO NOT SCALE FROM THIS PRINT.

** -MW: METAL WASHER (ONE PER POSITION)
(-D & -Q BODY SPECS ONLY)
(SEE NOTE 6 ON SHEET 1)

** - MW OPTION, DO NOT DESIGN IN. SAMTEC WILL ONLY SUPPORT EXISTING BUSINESS 2/08/02.

| | | | |
|------------------------------|-----------------------------------|-----------------|------|
| DIMENSIONS ARE IN INCHES | | TOLERANCES ARE: | |
| ONE PLACE DECIMALS ±.1[2.5] | THREE PLACE DECIMALS ± .005 [.13] | ANGLES | ± 2° |
| TWO PLACE DECIMALS ±.01[.25] | FOUR PLACE DECIMALS ±.0020[.05] | | |

TITLE: 2mm TERMINAL STRIP ASSEMBLY

DWG NO: MTMM-1XX-XX-XX-X-XXX-XX-XXX
SHEET 2 OF 2

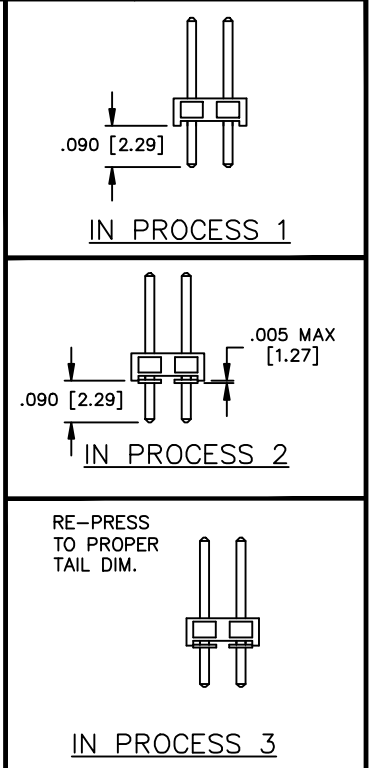
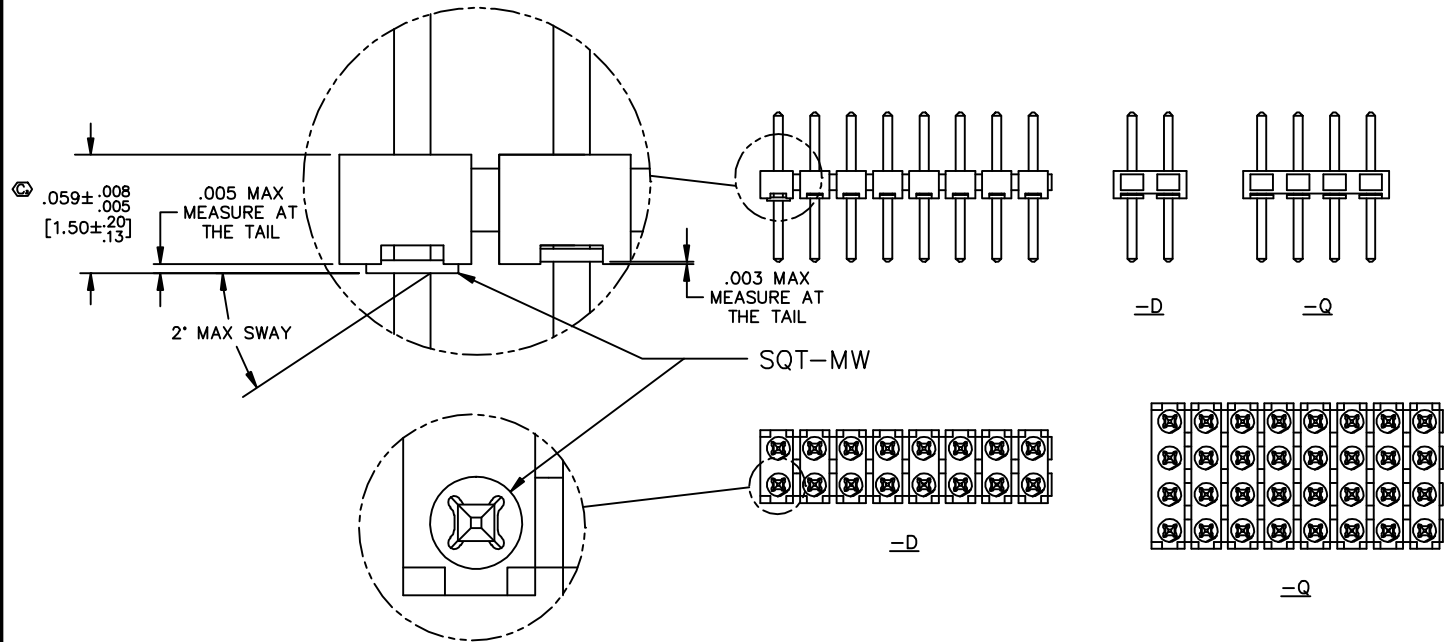

IN PROCESS 4
-T PLATING ONLY

| LEAD STYLE | MAX NUMBER OF BAND MARKS ALLOWED IN THE POST AREA | | | |
|------------|---|-------|-------|-------|
| | PIN A | PIN B | PIN C | PIN D |
| -02 | 1 | 1 | 1 | 1 |
| -03 | 2 | 2 | 2 | 2 |
| -04 | 2 | 2 | 2 | 2 |
| -05 | 2 | 2 | 2 | 2 |
| -06 | 2 | 2 | 2 | 2 |
| -07 | 2 | 2 | 2 | 2 |
| -08 | 2 | 2 | 2 | 2 |
| -09 | 2 | 2 | 2 | 2 |
| -10 | 2 | 2 | 2 | 2 |
| -11 | 2 | 2 | 2 | 2 |
| -12 | 2 | 2 | 2 | 2 |
| *-13 | 2 | 2 | 2 | 2 |
| *-14 | 2 | 2 | 2 | 2 |
| -15 | 2 | 2 | 2 | 2 |

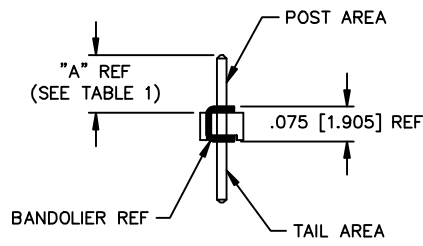

* PINS TO BE FLIPPED OPPOSITE OF SELECTIVE PLATING BEFORE BEING INSERTED

(SEE NOTE 7)
(SEE TABLE 3)

| BODY SPECIFICATION | LEAD STYLE | PKG TUBE | TUBE PLUG |
|--------------------|-------------------------|---------------|-----------|
| -D | -02, -03, -04, -05, -06 | PT-1-24-02-17 | TP-24 |
| | -07, -08, -09, -10 | PT-1-24-03-75 | TP-03 |
| | -11, 12, 13, -14 | PT-1-24-02-48 | TP-03 |
| | -15 | PT-1-24-02-47 | TP-03 |
| -Q | -02, -03, -04, -05, -06 | PT-1-24-02-17 | TP-03 |
| | -07, -08, -09 | PT-1-24-01-40 | TP-24 |
| | -10, -11 | PT-1-24-02-29 | TP-24 |
| | -12, -13, -14, -15 | PT-1-24-02-51 | TP-07 |

PROPRIETARY NOTE
THIS DOCUMENT CONTAINS INFORMATION CONFIDENTIAL AND PROPRIETARY TO SAMTEC INC. AND SHALL NOT BE REPRODUCED OR TRANSMITTED TO OTHER DOCUMENTS OR DISCLOSED TO OTHERS OR USED FOR ANY PURPOSE OTHER THAN THAT FOR WHICH IT WAS OBTAINED WITHOUT THE EXPRESSED WRITTEN CONSENT OF SAMTEC INC.

samtec
EXISPROD\ASSEMBLY\2MM
MTMMASM2
520 PARK EAST BLVD. NEW ALBANY, INDIANA 47150
PHONE (812) 944-6733 P.O. BOX 1147
CODE 55322

MADE BY: M. CARTER 7-10-98
PLOT SCALE 1=2
MTMM-1XX-XX-XX-X-XXX-XX-XXX
SHEET 2 OF 2

Mouser Electronics

Authorized Distributor

Click to View Pricing, Inventory, Delivery & Lifecycle Information:

[Samtec:](#)

[MTMM-107-02-T-D-196](#)