

DO NOT SCALE FROM THIS PRINT

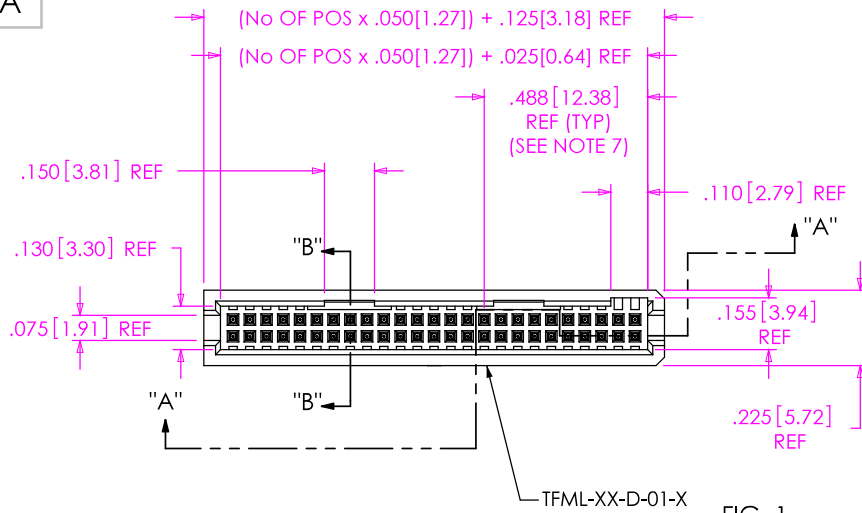
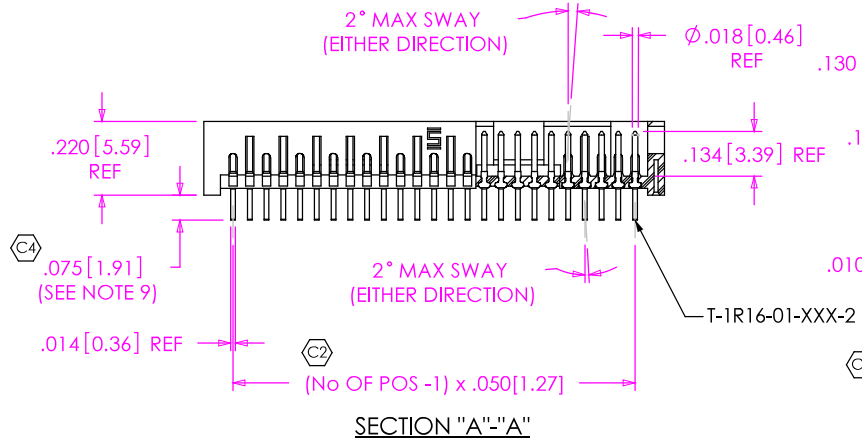
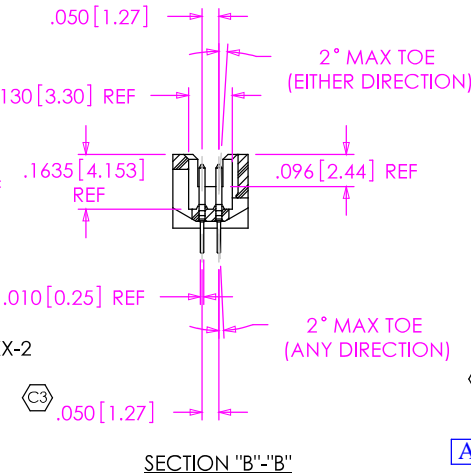

FIG. 1

-01: THROUGH HOLE



SECTION "A"-"A"



SECTION "B"-"B"

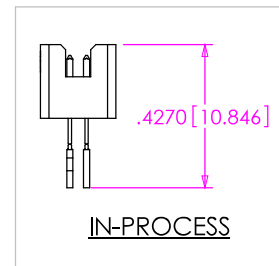

IN-PROCESS

No OF POSITIONS

-10 THRU -50
(PER ROW)

LEAD STYLE

-01: THROUGH HOLE
(SEE FIG. 1)
-02: SURFACE MOUNT
(SEE FIG.3, SHT 2)

PLATING SPECIFICATION

-S: SELECTIVE (USE T-1R16-XX-S-X)
-L: LIGHT SELECTIVE (USE T-1R16-XX-L-X)
-F: FLASH GOLD (USE T-1R16-XX-F-X)
-P: GOLD FLASH PALLADIUM NICKEL
(USE T-1R16-XX-P-X)
-H: HEAVY GOLD (USE T-1R16-XX-H-X)
-FM: SELECTIVE FLASH GOLD, MATTE TIN TAIL
(USE T-1R16-XX-F-X)
-LM: SELECTIVE LIGHT GOLD, MATTE TIN TAIL
(USE T-1R16-XX-L-X)
-SM: SELECTIVE HEAVY GOLD, MATTE TIN TAIL
(USE T-1R16-XX-S-X)
-STL: SELECTIVE TIN LEAD
(USE T-1R16-XX-STL-X)

OPTION

-A: ALIGNMENT PIN (USE TFML-XX-D-01-A)
(SEE FIG. 7, SHT 3)
-LC: LOCKING CLIP (USE LC-05-TM)
(SEE FIG. 9, SHT 3, N/A ON -RA OPTION)
-P: PICK & PLACE PAD (USE PPP-04)
(AVAIL IN ALL POSITIONS, N/A ON -RA
OPTION, SEE FIG. 5, SHT 2)
-RA: RIGHT ANGLE (LEAD STYLE -01 ONLY)
(SEE FIG. 4, SHT 2)
-TR: TAPE & REEL (SEE FIG. 2)
-SA: STAKED ALIGNMENT PIN (USE SM-A5)
(SEE FIG. 8, SHT 3)
-K: POLYAMIDE FILM (USE K-500-300)
(SEE FIG. 6, SHT 2)
-SN: SOLDER NAIL (USE TFML-XX-D-01-SN &
WT-27-01-T) (SEE FIG. 10, SHEET 4)
(AVAILABLE ON -02 LEAD STYLE ONLY)

ROW SPECIFICATION

-D: DOUBLE ROW

NOTES:

1. Ⓢ REPRESENTS A CRITICAL DIMENSION.
2. COPLANARITY: POSITIONS -10 THRU -26: .004[0.10]
POSITIONS -27 THRU -50: .006[0.15].
3. MANUFACTURING IN-PROCESS DIMENSION
DESIGNED TO ACHIEVE FINISHED ASSEMBLY.
4. MINIMUM PUSHOUT FORCE: 1.0 LB [4.4 N].
5. MAXIMUM ALLOWABLE BOW: .004 INCH/INCH
[0.10 MM/MM] AFTER ASSEMBLY.
6. MEASURED FROM BEND.
7. POSITIONS -10 THROUGH -24 WILL HAVE ONLY
ONE CLIP AT DIMENSION SHOWN;
POSITIONS -25 THROUGH -34 WILL HAVE TWO
CLIPS AT DIMENSION SHOWN;
POSITIONS -35 THROUGH -50 WILL HAVE THREE
CLIPS: TWO AT DIMENSION SHOWN & ONE
CENTERED ON INSULATOR.
8. NOTE DELETED.
9. .003[0.08] MAXIMUM TERMINAL BURR
10. .005[0.13] MAXIMUM HEIGHT VARIATION BETWEEN
ANY TWO PINS.

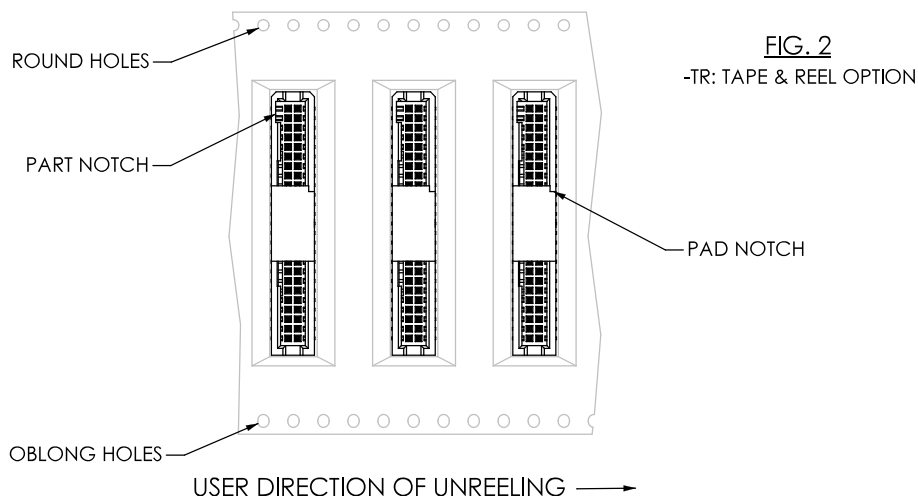

FIG. 2

-TR: TAPE & REEL OPTION

UNLESS OTHERWISE SPECIFIED,
DIMENSIONS ARE IN INCHES.

TOLERANCES ARE:

DECIMALS ANGLES
.XX: ±.01
.XXX: ±.005
.XXXX: ±.0020

PROPRIETARY NOTE

THIS DOCUMENT CONTAINS INFORMATION
CONFIDENTIAL AND PROPRIETARY TO
SAMTEC, INC. AND SHALL NOT BE REPRODUCED
OR TRANSFERRED TO OTHER DOCUMENTS OR
DISCLOSED TO OTHERS OR USED FOR ANY
PURPOSE OTHER THAN THAT WHICH IT WAS
OBTAINED WITHOUT THE EXPRESSED WRITTEN
CONSENT OF SAMTEC, INC.



520 PARK EAST BLVD, NEW ALBANY, IN 47150
PHONE: 812-944-6733 FAX: 812-948-5047
e-Mail: info@SAMTEC.com code: 55322

MATERIAL:
VETRA E130I, COLOR: BLACK
CONTACT: PHOS BRONZE, THICKNESS: .018

DO NOT SCALE DRAWING

SHEET SCALE: 1:75:1

DESCRIPTION:
.050 SHROUDED TERMINAL ASSEMBLY

DWG. NO.
TFML-1XX-XX-XXX-D-XX

BY: DEANP 4/8/99 SHEET 1 OF 4

FIG. 3

-02: SURFACE MOUNT
(SHOWN: TFML-125-02-XXX-D)
(SAME AS FIG. 1, UNLESS OTHERWISE STATED)

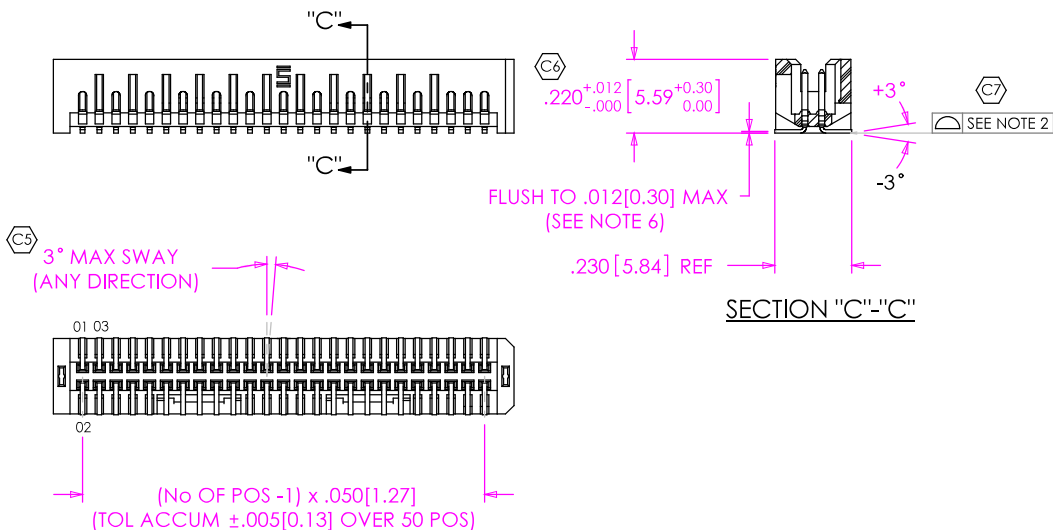

FIG. 5

-P: PICK & PLACE PAD OPTION
(SHOWN: TFML-125-02-XXX-D-P)
(SAME AS FIG. 1, UNLESS OTHERWISE STATED)

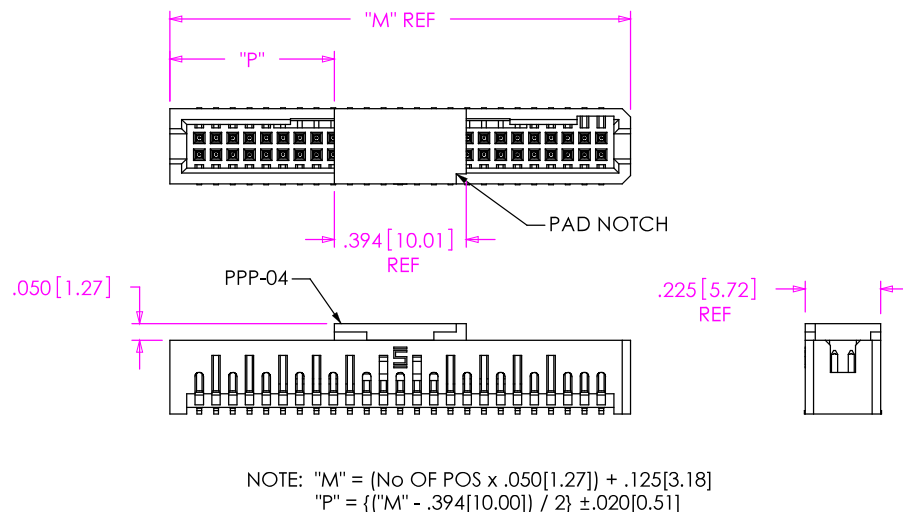

FIG. 4

-RA: RIGHT ANGLE OPTION
(SHOWN: TFML-125-01-XXX-D-RA)
(SAME AS FIG. 1, UNLESS OTHERWISE STATED)

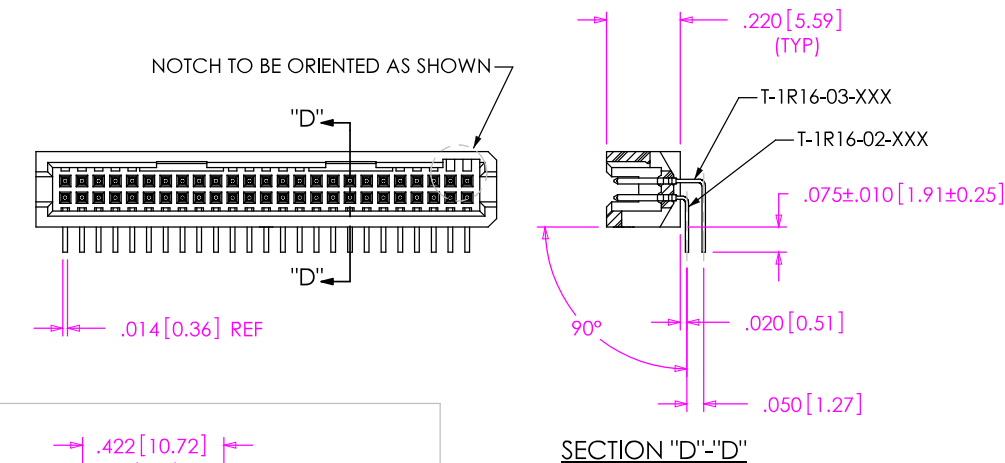
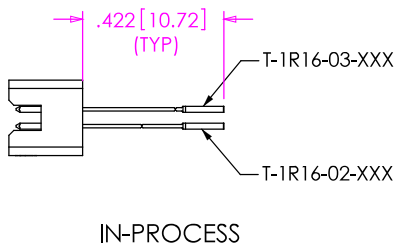
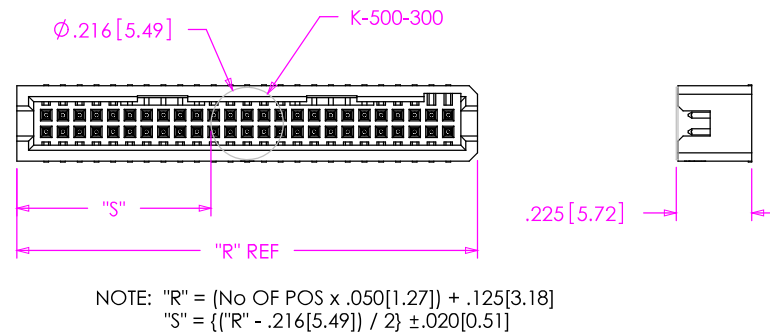

FIG. 6

-K: POLYAMIDE FILM PAD OPTION
(SHOWN: TFML-125-02-XXX-D-K)
(SAME AS FIG. 1, UNLESS OTHERWISE STATED)



F:\DWG\MISC\MKTG\TFML-1XX-XX-XXX-D-XX-MKT.SLDDRW

PROPRIETARY NOTE

THIS DOCUMENT CONTAINS INFORMATION CONFIDENTIAL AND PROPRIETARY TO SAMTEC, INC. AND SHALL NOT BE REPRODUCED OR TRANSFERRED TO OTHER DOCUMENTS OR DISCLOSED TO OTHERS OR USED FOR ANY PURPOSE OTHER THAN THAT WHICH IT WAS OBTAINED WITHOUT THE EXPRESSED WRITTEN CONSENT OF SAMTEC, INC.

DO NOT SCALE DRAWING

SHEET SCALE: 1.75:1



520 PARK EAST BLVD, NEW ALBANY, IN 47150
PHONE: 812-944-6733 FAX: 812-948-5047
e-Mail: info@SAMTEC.com code: 55322

DESCRIPTION:
.050 SHROUDED TERMINAL ASSEMBLY

DWG. NO.
TFML-1XX-XX-XXX-D-XX

BY: DEANP 4/8/99 SHEET 2 OF 4

PACKAGING VIEWS

PARTS TO BE POSITIONED WITH POLARIZING NOTCH FACING THE SAMTEC LOGO AND ARROW.

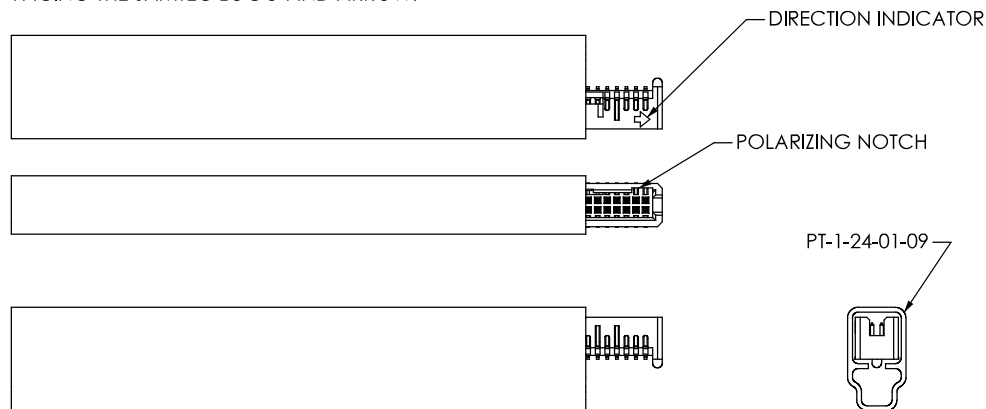

PARTS TO BE POSITIONED WITH TAILS FACING LOGO SIDE OF TUBE AND POLARIZING NOTCH ORIENTED AS SHOWN

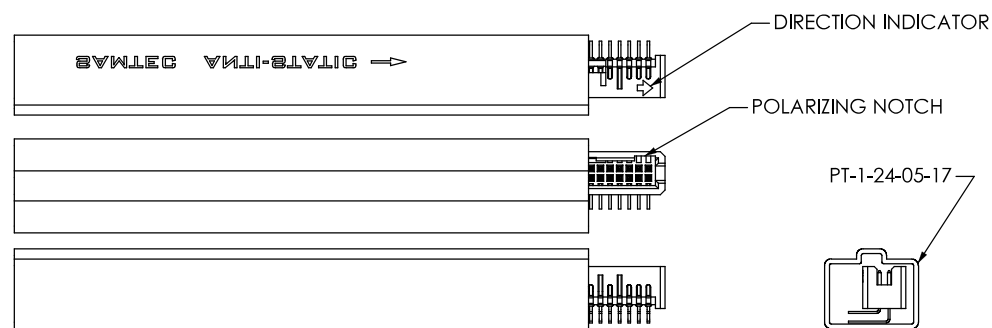

POSITION PARTS WITH POLARIZING NOTCH ORIENTED AS SHOWN

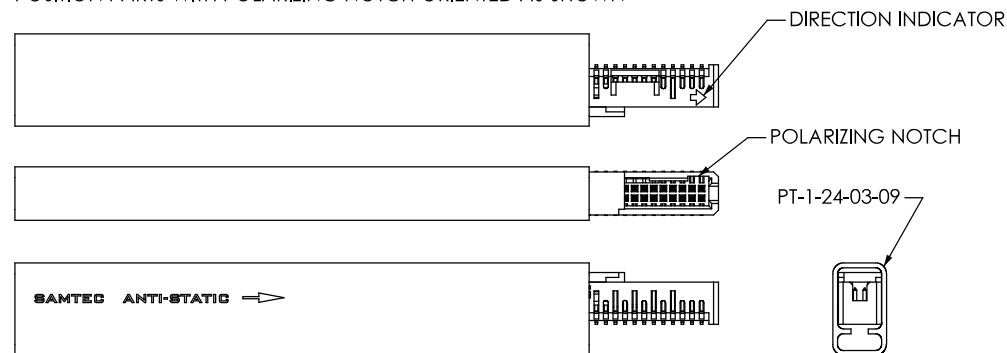

LEAD STYLE	PACKAGING TUBE	PLUG
-RA ONLY	PT-1-24-05-17	TP-07
-01,-02 EXCEPT -RA OR -P	PT-1-24-01-09	TP-24
-01-P,-02-P	PT-1-24-03-09	TP-03

FIG. 7

-A: ALIGNMENT PIN OPTION
(SHOWN: TFML-125-02-XXX-D-A)
(SAME AS FIG. 1, UNLESS OTHERWISE STATED)
-NOT AVAILABLE WITH -RA

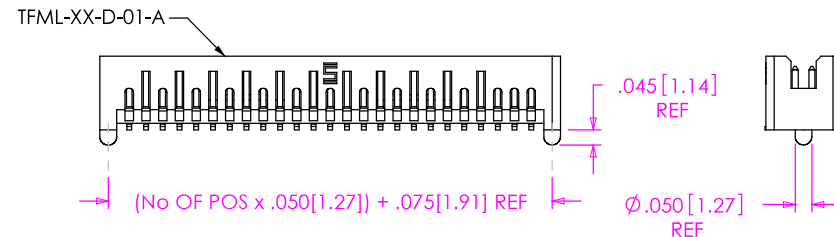

FIG. 8

-SA: STAKED ALIGNMENT PIN OPTION
(SHOWN: TFML-125-02-XXX-D-SA)
(SAME AS FIG. 1, UNLESS OTHERWISE STATED)
-NOT AVAILABLE ON -RA

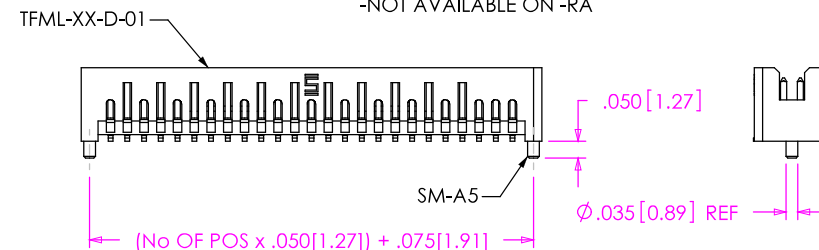
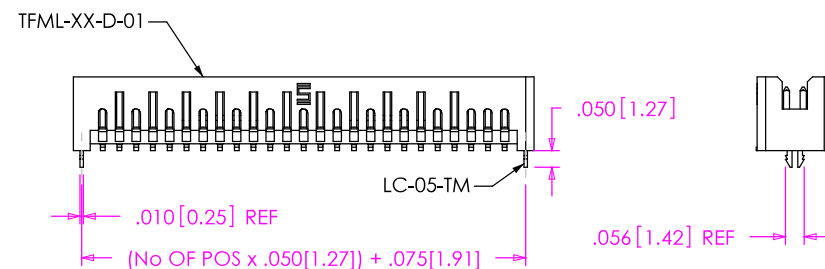

FIG. 9

-LC: LOCKING CLIP OPTION
(SHOWN: TFML-125-02-XXX-D-LC)
(SAME AS FIG. 1, UNLESS OTHERWISE STATED)
-NOT AVAILABLE ON -RA



F:\DWG\MISC\MKTG\TFML-1XX-XX-XXX-D-XX-MKT.SLDDRW

PROPRIETARY NOTE

THIS DOCUMENT CONTAINS INFORMATION CONFIDENTIAL AND PROPRIETARY TO SAMTEC, INC. AND SHALL NOT BE REPRODUCED OR TRANSFERRED TO OTHER DOCUMENTS OR DISCLOSED TO OTHERS OR USED FOR ANY PURPOSE OTHER THAN THAT WHICH IT WAS OBTAINED WITHOUT THE EXPRESSED WRITTEN CONSENT OF SAMTEC, INC.

DO NOT SCALE DRAWING

SHEET SCALE: 1.75:1



520 PARK EAST BLVD, NEW ALBANY, IN 47150
PHONE: 812-944-6733 FAX: 812-948-5047
e-Mail: info@SAMTEC.com code: 55322

DESCRIPTION:
.050 SHROUDED TERMINAL ASSEMBLY

DWG. NO.
TFML-1XX-XX-XXX-D-XX

BY: DEANP 4/8/99 SHEET 3 OF 4

FIG. 10
 -SN: SOLDER PIN OPTION
 (SHOWN: TFML-125-02-XXX-D-SN)
 (SAME AS FIG. 1, UNLESS OTHERWISE STATED)
 (ONLY AVAILABLE ON -02 LEAD STYLE)

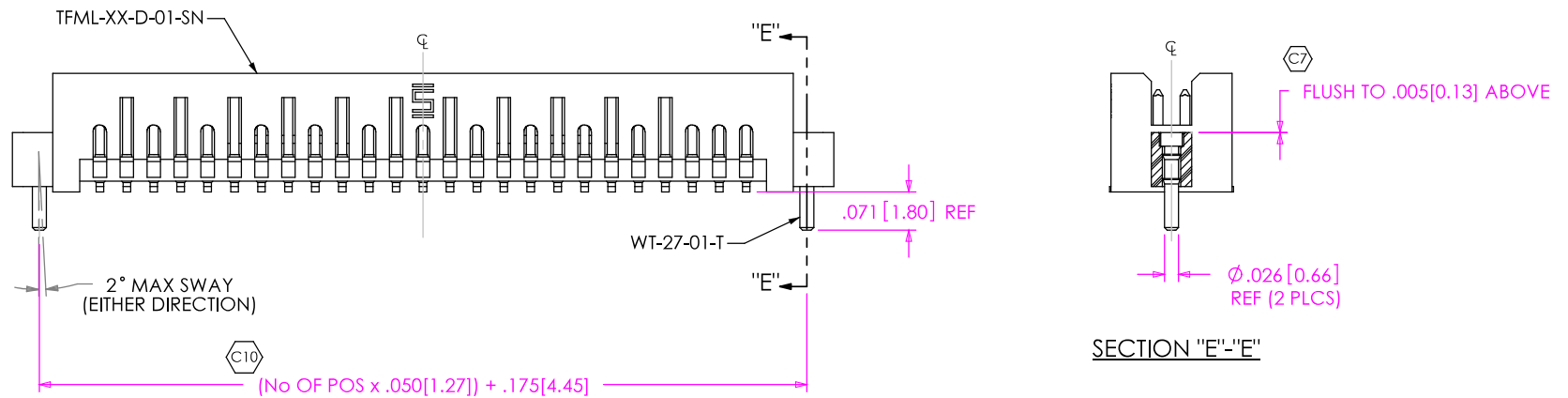

PROPRIETARY NOTE
 THIS DOCUMENT CONTAINS INFORMATION CONFIDENTIAL AND PROPRIETARY TO SAMTEC, INC. AND SHALL NOT BE REPRODUCED OR TRANSFERRED TO OTHER DOCUMENTS OR DISCLOSED TO OTHERS OR USED FOR ANY PURPOSE OTHER THAN THAT WHICH IT WAS OBTAINED WITHOUT THE EXPRESSED WRITTEN CONSENT OF SAMTEC, INC.

DO NOT SCALE DRAWING

SHEET SCALE: 3:1

samtec	
520 PARK EAST BLVD, NEW ALBANY, IN 47150 PHONE: 812-944-6733 FAX: 812-948-5047 e-Mail: info@SAMTEC.com code: 55322	
DESCRIPTION: .050 SHROUDED TERMINAL ASSEMBLY	
DWG. NO. TFML-1XX-XX-XXX-D-XX	
BY: DEANP	4/8/99
SHEET 4 OF 4	

Mouser Electronics

Authorized Distributor

Click to View Pricing, Inventory, Delivery & Lifecycle Information:

[Samtec:](#)

[TFML-150-02-H-D-A](#)