

RIGHT ANGLE JACK RECEPTACLE FOR PCB

R124.681.800

SOLDER LEGS

Series : SMA-COM

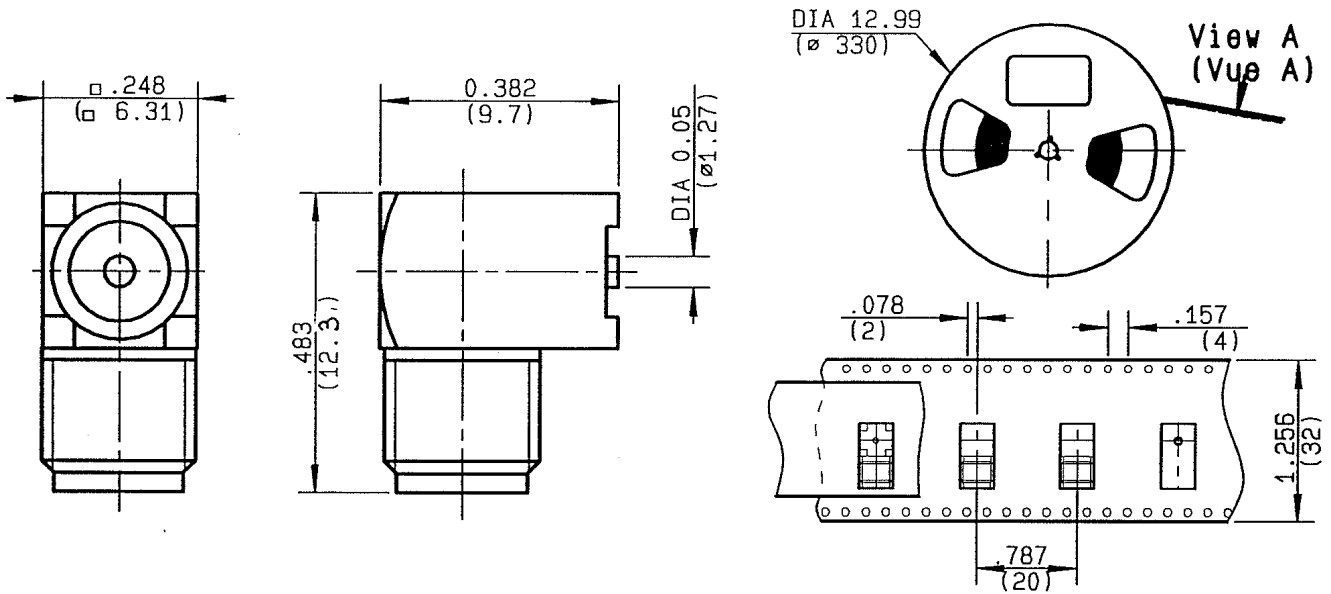

All dimensions are in mm.

COMPONENTS	MATERIALS	PLATINGS (µm)
BODY	BRASS	GOLD 0.2 OVER NICKEL 2
CENTER CONTACT	BERYLLIUM COPPER	GOLD 0.5 OVER NICKEL 2
OUTER CONTACT	-	-
INSULATOR	PTFE	-
GASKET	-	-
OTHERS PARTS	-	-
-	-	-
-	-	-

Issue : 0430 B

In the effort to improve our products, we reserve the right to make changes judged to be necessary.



RIGHT ANGLE JACK RECEPTACLE FOR PCB

R124.681.800

SOLDER LEGS

Series : SMA-COM

PACKAGING

SPECIFICATION

Standard	Unit	Other
100	'W' option	Contact us

ELECTRICAL CHARACTERISTICS

ENVIRONMENTAL

Impedance		50 Ω
Frequency		0-6 GHz
VSWR	1.16 +	0.000 x F(GHz) Maxi
Insertion loss		0.07 √F(GHz) dB Maxi
RF leakage	- (60 - F(GHz)) dB Maxi
Voltage rating		500 Veff Maxi
Dielectric withstanding voltage		1000 Veff mini
Insulation resistance		5000 MΩ mini

Operating temperature	-65/+165 ° C
Hermetic seal	NA Atm.cm3/s
Panel leakage	NA

OTHERS CHARACTERISTICS

Assembly instruction

Others :

MECHANICAL CHARACTERISTICS

Center contact retention		
Axial force – Mating end	15	N mini
Axial force – Opposite end	15	N mini
Torque	1	N.cm mini
Recommended torque		
Mating	40	N.cm
Panel nut	NA	N.cm
Mating life	100	Cycles mini
Weight	3.000	g

Issue : 0430 B

In the effort to improve our products, we reserve the right to make changes judged to be necessary.



RIGHT ANGLE JACK RECEPTACLE FOR PCB

R124.681.800

SOLDER LEGS

Series : SMA-COM

SOLDER PROCEDURE

1. Deposition of solder paste 'Sn Ag4 Cu0.5' on mounting zone by screen printing application. We recommend a low residue flux.
We advise a thickness of 150 microns (5.850 microinch). Verify that the edges of the zone are clean.
2. Placement of the receptacle on the mounting zone with an automatic machine of 'pick and place' type. Aspiration port (see page 4) centered into body and push against it.
Video camera is recommended for the positioning of the component. Adhesive agents must not be used on the receptacle.
3. Soldering by infra-red reflow.
Below, please find the typical profile to use.
4. Cleaning of printed circuit boards by CFC solvents (or a substitute product according to united nation's environmental program.)
5. Checking of solder joints and position of the component by visual inspection.

TEMPERATURE PROFILE

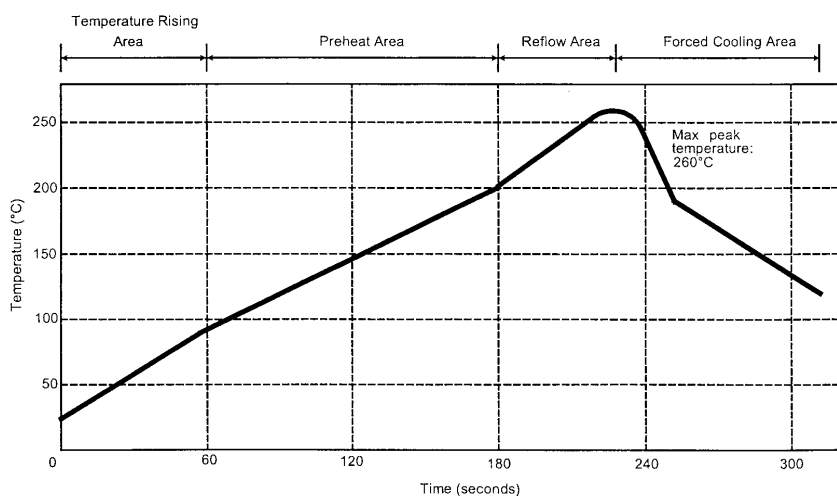

Parameter	Value	Unit
Temperature rising Area	1 - 4	°C/sec
Max Peak Temperature	260	°C
Max dwell time @260°C	10	sec
Min dwell time @235°C	20	sec
Max dwell time @235°C	60	sec
Temperature drop in cooling Area	-1 to - 4	°C/sec
Max dwell time above 100°C	420	sec

Issue : 0430 B

In the effort to improve our products, we reserve the right to make changes judged to be necessary.



RIGHT ANGLE JACK RECEPTACLE FOR PCB

R124.681.800

SOLDER LEGS

Series : SMA-COM

SMA B SERIES - INFORMATIONS

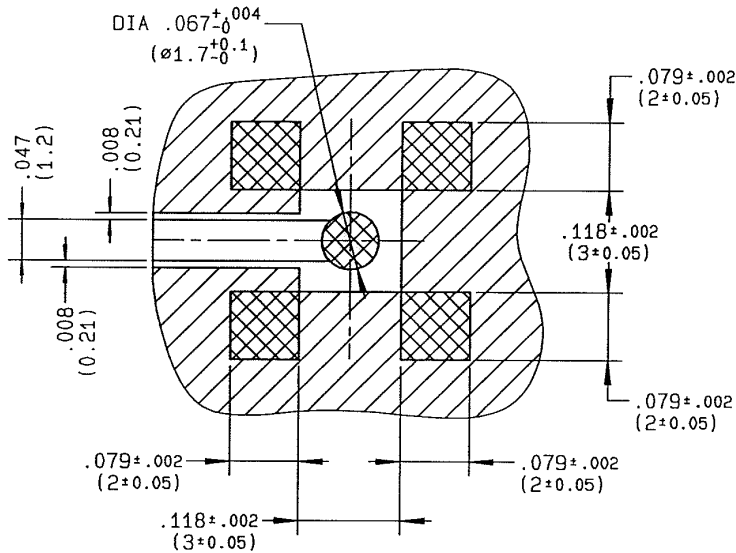

COPLANAR LINE

Pattern and signal are on the same side

Thickness of PCB : $.063$ (1.6 mm)

The material of PCB is the epoxy resin of glass fabrics bacs. ($E_r = 4.8$)

The solder resist should be printed except for the land pattern on the PCB.



Pattern



Land for solder paste

SHADOW OF "SMA B" RECEPTACLE FOR VIDEO CAMERA

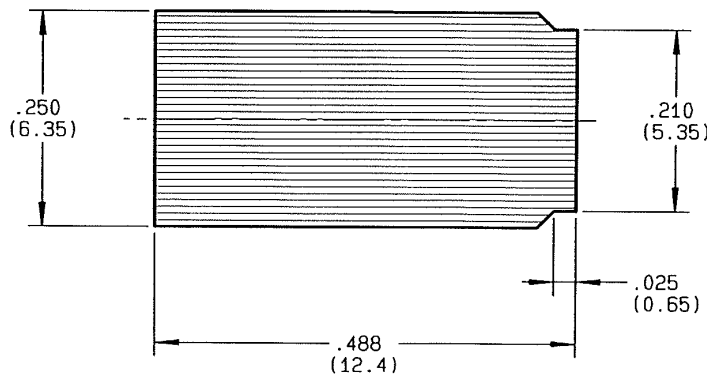

Issue : 0430 B

In the effort to improve our products, we reserve the right to make changes judged to be necessary.



RADIALL®

Mouser Electronics

Authorized Distributor

Click to View Pricing, Inventory, Delivery & Lifecycle Information:

[Radial:](#)

[R124681800](#)