

STRAIGHT JACK SOLDER TYPE

R121.222.000

CABLE .085

Series : SSMA

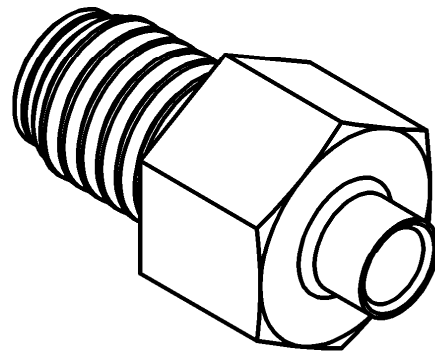
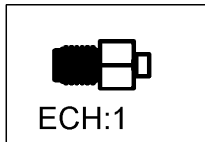
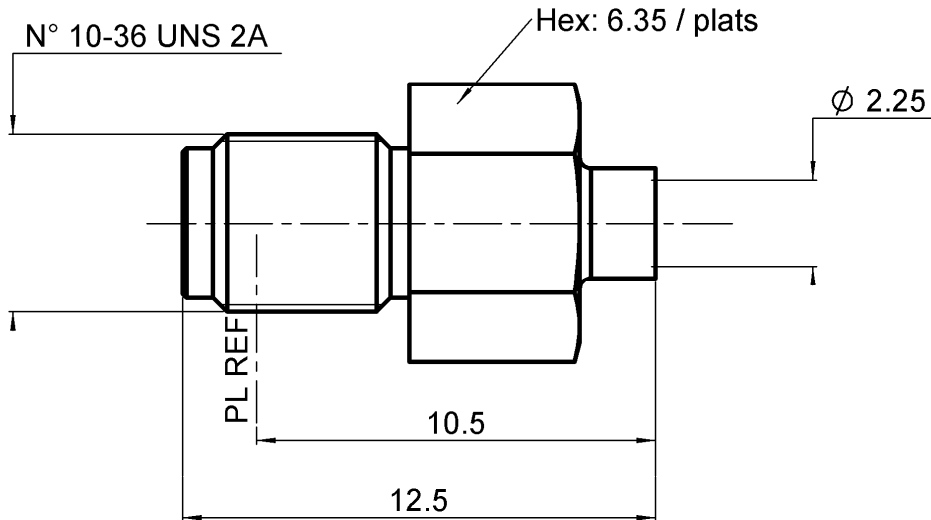

All dimensions are in mm.

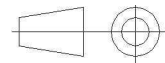

COMPONENTS	MATERIALS	PLATING (µm)
BODY	-	NICKEL 2
CENTER CONTACT	- BERYLLIUM COPPER	GOLD 2.5 OVER NICKEL 2
OUTER CONTACT	-	-
INSULATOR	- PTFE	-
GASKET	-	-
OTHERS PARTS	-	-
-	-	-
-	-	-

Issue : 0931 C

In the effort to improve our products, we reserve the right to make changes judged to be necessary.



STRAIGHT JACK SOLDER TYPE

R121.222.000

CABLE .085

Series : SSMA

PACKAGING

Standard	Unit	Other
1		Contact us

SPECIFICATION

ELECTRICAL CHARACTERISTICS

Impedance		50 Ω
Frequency		0-18 GHz
VSWR	A.D. + 0,0000	x F(GHz) Maxi
Insertion loss	A.D.	√F(GHz) dB Maxi
RF leakage	- (- F(GHz)) dB Maxi
Voltage rating		250 Veff Maxi
Dielectric withstanding voltage		750 Veff mini
Insulation resistance		1000 MΩ mini

CABLE ASSEMBLY

Stripping	a	b	c	d	e	f
mm	1,80	0,00	0,00	0,00	0,00	0,00

Assembly instruction : **Solder 01**

Recommended cable(s)
 BELN 1671A
 RG 405
 KS 1

Characteristics indicated on this data sheet are those that can be achieved with the highest performance cable. Intrinsic limitations of the cable may diminish the performance of the assembly

Cable retention

- pull off **200** N mini
 - torque - N.cm

MECHANICAL CHARACTERISTICS

Center contact retention		
Axial force – Mating end	22	N mini
Axial force – Opposite end	22-	N mini
Torque	-	N.cm mini

TOOLING

Part Number	Description	Hexagon
.	.	.
R282.051.000	STRIPPING TOOL	
R282.062.000	POINTER GAUGE	
R282.862.050	SOLDER GAUGE THCK .012	
R282.730.033	INSULATOR MOUNTING TOOL	
R282.740.000	SOLDERING MOUNTING	

Recommended torque		
Mating	-	N.cm
Panel nut	-	N.cm
Clamp nut	-	N.cm
A/F clamp nut	0,0000	mm

Mating life	500	Cycles mini
Weight	1,5200	g

ENVIRONMENTAL

Operating temperature	-55/+115	°C
Hermetic seal	-	Atm.cm3/s
Panel leakage	-	

OTHER CHARACTERISTICS

Issue : 0931 C

In the effort to improve our products, we reserve the right to make changes judged to be necessary.



Mouser Electronics

Authorized Distributor

Click to View Pricing, Inventory, Delivery & Lifecycle Information:

[Radial:](#)

[R121222000](#)