

**MALE STRAIGHT RECEPTACLE FOR PCB**

**R114.424.100**

**SMT TYPE- REEL OF 100**

Series : SMB

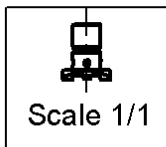
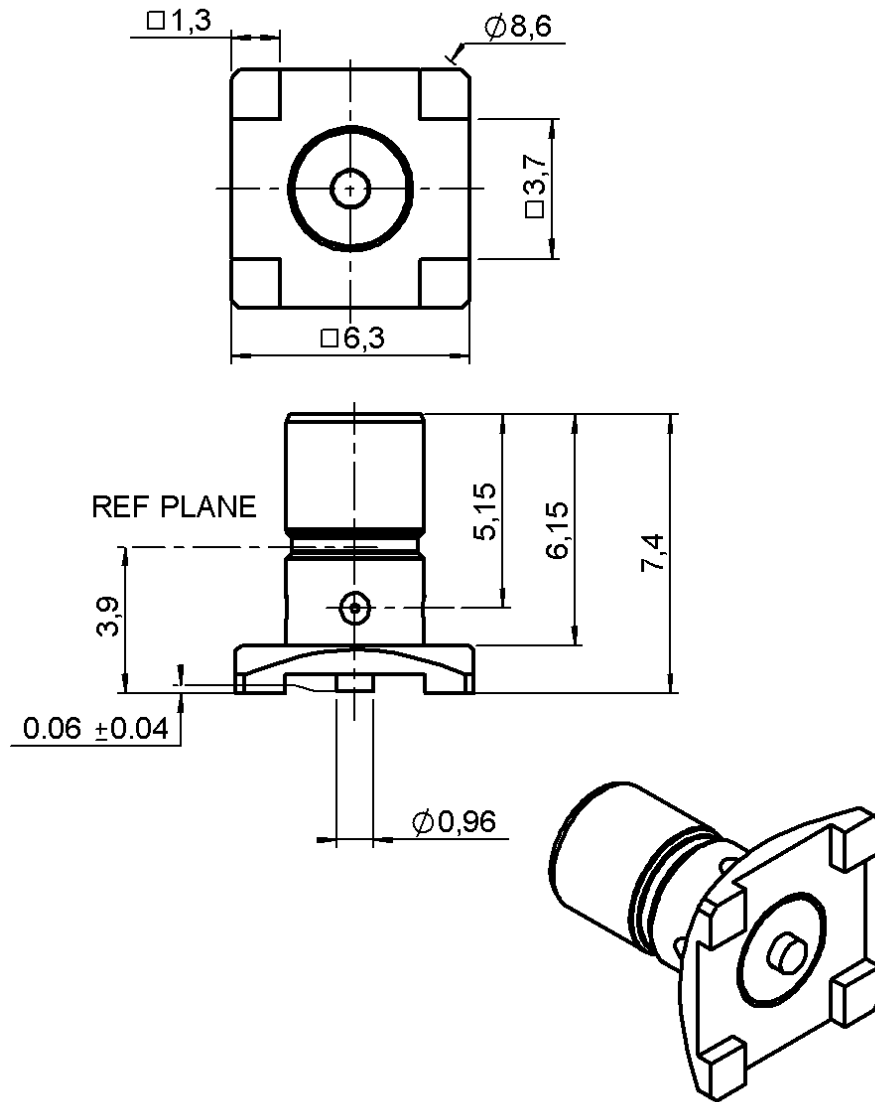

All dimensions are in mm.

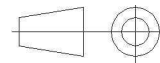

COMPONENTS	MATERIALS	PLATINGS (µm)
BODY	BRASS	GOLD 0.2 OVER NICKEL 2
CENTER CONTACT	BRASS	GOLD 0.5 OVER NICKEL 2
OUTER CONTACT	-	-
INSULATOR	PTFE	-
GASKET	-	-
OTHERS PARTS	-	-
-	-	-
-	-	-

Issue : 0847 C

In the effort to improve our products, we reserve the right to make changes judged to be necessary.



**MALE STRAIGHT RECEPTACLE FOR PCB**

**R114.424.100**

**SMT TYPE- REEL OF 100**

Series : **SMB**

**PACKAGING**

**SPECIFICATION**

Standard	Unit	Other
<b>100</b>	<b>'W' option</b>	<b>Contact us</b>

**ELECTRICAL CHARACTERISTICS**

Impedance	<b>50</b>	$\Omega$
Frequency	<b>0-4</b>	GHz
VSWR	<b>1.05*</b> + <b>0,0080</b>	x F(GHz) Maxi
Insertion loss	<b>0.03*</b>	$\sqrt{F}$ (GHz) dB Maxi
RF leakage	- ( <b>57</b> )	- F(GHz)) dB mini
Voltage rating	<b>500</b>	Veff Maxi
Dielectric withstanding voltage	<b>1000</b>	Veff mini
Insulation resistance	<b>1000</b>	M $\Omega$ mini

**ENVIRONMENTAL**

Operating temperature	<b>-65/+165</b>	$^{\circ}$ C
Hermetic seal	<b>NA</b>	Atm.cm <sup>3</sup> /s
Panel leakage	<b>NA</b>	

**OTHERS CHARACTERISTICS**

Assembly instruction

Others :

\* COAXIAL TRANSMISSION LINE ONLY

**MECHANICAL CHARACTERISTICS**

Center contact retention		
Axial force – Mating end	<b>10</b>	N mini
Axial force – Opposite end	<b>10</b>	N mini
Torque	<b>NA</b>	N.cm mini
Recommended torque		
Mating	<b>NA</b>	N.cm
Panel nut	<b>NA</b>	N.cm
Mating life	<b>500</b>	Cycles mini
Weight	<b>0,4830</b>	g

Issue : 0847 C

In the effort to improve our products, we reserve the right to make changes judged to be necessary.



**MALE STRAIGHT RECEPTACLE FOR PCB**

**R114.424.100**

**SMT TYPE- REEL OF 100**

Series : SMB

**SMB SERIES – INFORMATION**

Coplanar line : pattern and signal are on the same side. Thickness of PCB : 1.6 mm

The material of PCB is the epoxy resin of glass fabrics bacs. (Er=4.8). The solder resist should be printed except for the land pattern on the PCB.

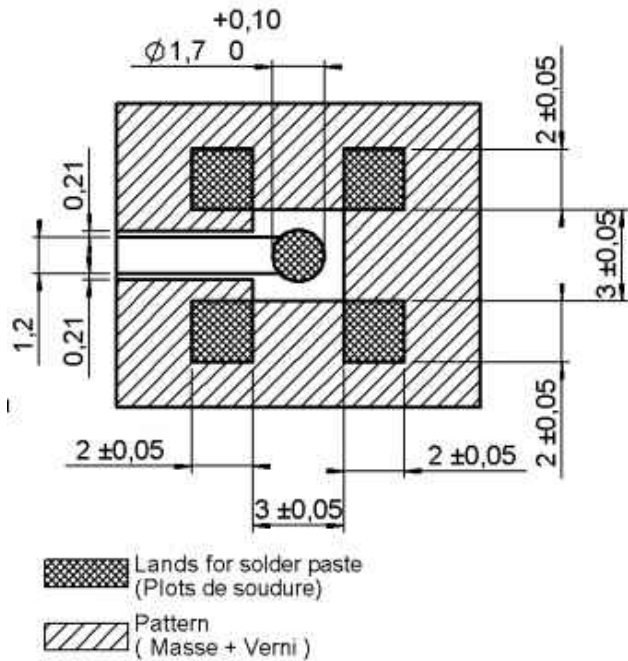

**SHADOW OF SMB RECEPTACLE FOR VIDEO CAMERA**

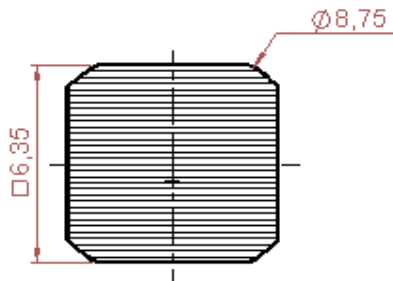

**ASRIRATION AREA**

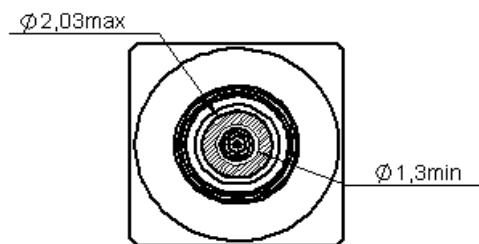

ASPIRATION AREA

Issue : 0847 C

In the effort to improve our products, we reserve the right to make changes judged to be necessary.



**MALE STRAIGHT RECEPTACLE FOR PCB**

**R114.424.100**

**SMT TYPE- REEL OF 100**

Series : **SMB**

**SOLDER PROCEDURE**

1. Deposit solder paste 'Sn Ag4 Cu0.5' on mounting zone by screen printing application. We recommend a low residue flux.  
We advise a thickness of 150 micromm ( 5.850 microinch ). Verify that the edges of the zone are clean.
2. Placement of the receptacle on the mounting zone with an automatic machine of 'pick and place' type.
3. Soldering by infra-red reflow.
4. Cleaning of printed circuit boards.
5. Checking of solder joints and position of the component by visual inspection.

**TEMPERATURE PROFILE**

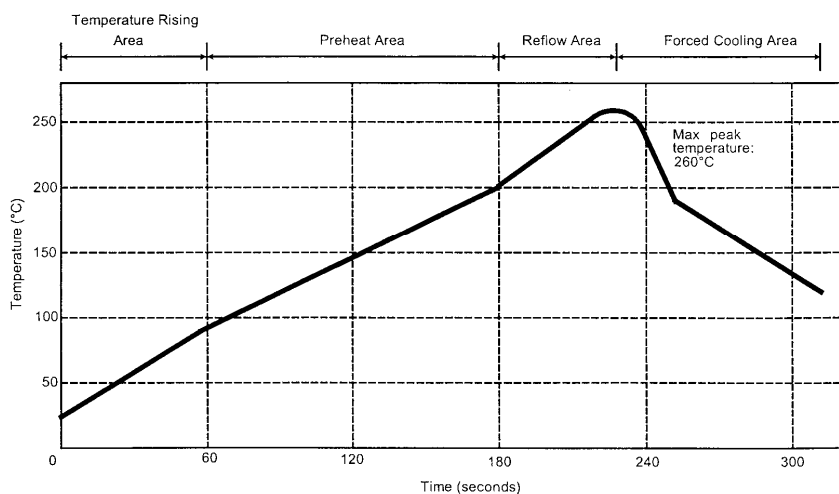

Parameter	Value	Unit
Temperature rising Area	1 - 4	°C/sec
Max Peak Temperature	260	°C
Max dwell time @260°C	10	sec
Min dwell time @235°C	20	sec
Max dwell time @235°C	60	sec
Temperature drop in cooling Area	-1 to - 4	°C/sec
Max dwell time above 100°C	420	sec

Issue : 0847 C

In the effort to improve our products, we reserve the right to make changes judged to be necessary.



**MALE STRAIGHT RECEPTACLE FOR PCB**

**R114.424.100**

**SMT TYPE- REEL OF 100**

Series : SMB

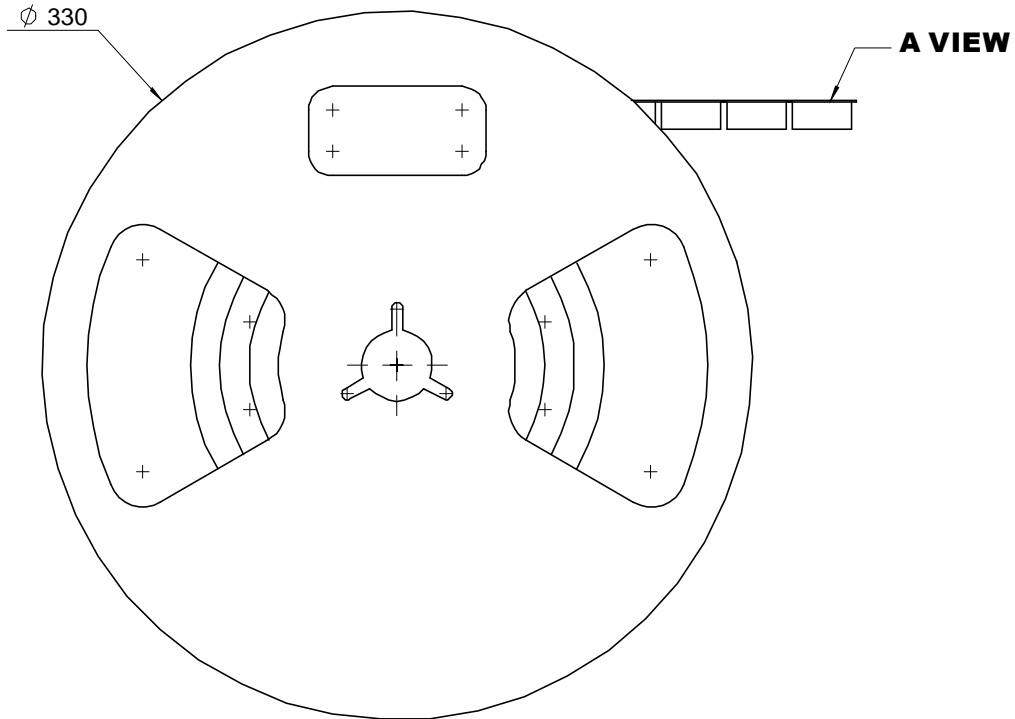

**A VIEW (Scale 3)**

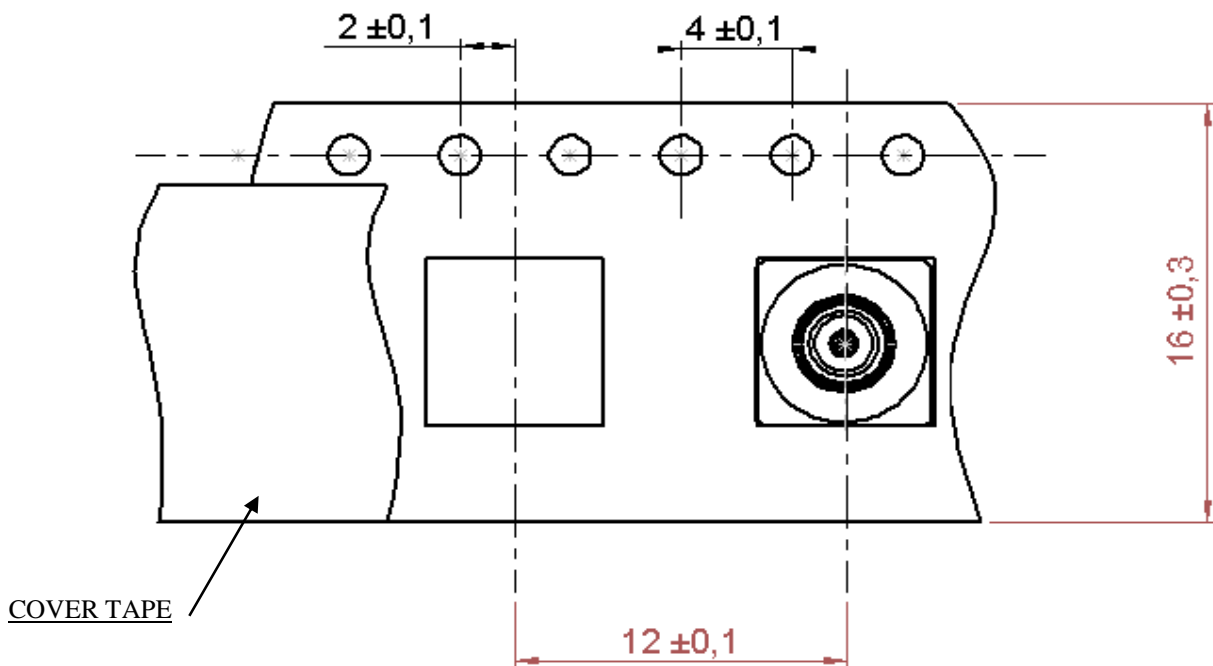

**Issue : 0847 C**

In the effort to improve our products, we reserve the right to make changes judged to be necessary.



# Mouser Electronics

Authorized Distributor

Click to View Pricing, Inventory, Delivery & Lifecycle Information:

Radial:

[R114424100](#)