

**Chip Inductor AWVI Series**

**Automotive  
AEC-Q200**

RoHS Compliant  
Halogen Free  
REACH Compliant

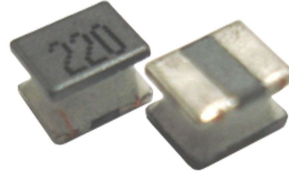

- RF  
Circuit
- Unshield
- Wire  
Wound
- Ferrite
- General  
Signal line

**Part Numbering**

A	WVI	00	322522	3R3	K	H2
Grade	Series Name	Control Code	Dimensions Code (mm)	Inductance (uH)	Tolerance	Internal Code
			322522 3.2x2.5x2.2	3R3 3.3 100 10	K ±10% J ±5%	

**AWVI00322522 Type**

**■ Dimensions**

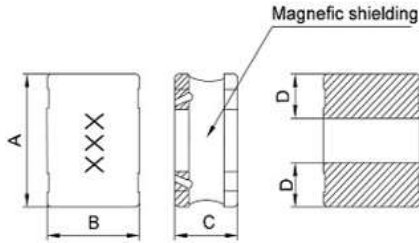

Dimensions in mm

TYPE	322522
A	3.2±0.2
B	2.5±0.2
C	2.2±0.2
D	1.1 typ

unit:mm

**■ Recommended Land Pattern**

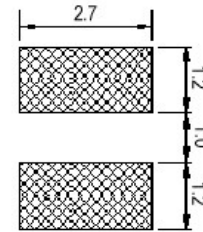

unit:mm

**■ Electrical Characteristics**

Part No.	Inductance (uH)	Test Freq. (MHz)	Q Min.	SRF (MHz)Min.	RDC (Ω)Max.	I <sub>rms</sub> (mA)Max.	Tolerance (±%)	Marking
AWVI00322522R68□H2	0.68	7.96/2.52	10	190	0.065	1400	5,10,20	R68
AWVI003225221R0□H2	1	7.96/2.52	10	150	0.1	1150	5,10,20	1R0
AWVI003225221R5□H2	1.5	7.96/2.52	10	110	0.14	900	5,10,20	1R5
AWVI003225221R8□H2	1.8	7.96/2.52	10	75	0.15	850	5,10,20	1R8
AWVI003225222R2□H2	2.2	7.96/2.52	10	70	0.16	800	5,10,20	2R2
AWVI003225222R7□H2	2.7	7.96/2.52	10	45	0.18	780	5,10,20	2R7
AWVI003225223R3□H2	3.3	7.96/2.52	10	45	0.18	770	5,10,20	3R3
AWVI003225224R7□H2	4.7	7.96/2.52	10	40	0.25	700	5,10,20	4R7
AWVI003225226R8□H2	6.8	7.96/2.52	10	35	0.35	570	5,10,20	6R8
AWVI00322522100□H2	10	2.52/2.52	12	25	0.46	500	5,10,20	100
AWVI00322522150□H2	15	2.52/2.52	12	20	0.72	390	5,10,20	150
AWVI00322522220□H2	22	2.52/2.52	12	14	1	330	5,10,20	220
AWVI00322522330□H2	33	2.52/2.52	15	10	1.4	280	5,10,20	330
AWVI00322522470□H2	47	2.52/2.52	15	8	2.1	230	5,10,20	470
AWVI00322522680□H2	68	2.52/2.52	15	8	3.4	180	5,10,20	680
AWVI00322522101□H2	100	0.796/0.796	17	6	4.8	150	5,10,20	101
AWVI00322522121□H2	120	0.796/0.796	17	5	6.2	140	5,10,20	121
AWVI00322522151□H2	150	0.796/0.796	17	5	7.5	120	5,10,20	151
AWVI00322522181□H2	180	0.796/0.796	17	4	9.8	110	5,10,20	181
AWVI00322522221□H2	220	0.796/0.796	17	4	10.9	100	5,10,20	221
AWVI00322522331□H2	330	0.796/0.796	17	3.5	13	90	5,10,20	331
AWVI00322522471□H2	470	0.796/0.796	17	2.5	20	76	5,10,20	471
AWVI00322522561□H2	560	0.796/0.796	10	2.5	27.0	70	5,10,20	561
AWVI00322522681□H2	680	0.796/0.796	10	2	31.0	61	5,10,20	681
AWVI00322522102□H2	1000	0.1/0.1	10	1.5	40.0	60	5,10,20	102

**Note: When ordering, please specify tolerance code. Tolerance: J=±5% / K=±10% / M=±20%**

1. Operating temperature range -40°C ~ 125°C (Including self - temperature rise)
2. I<sub>rms</sub> for a 15°C temperature rise from 25°C ambient with current
3. L/Q Test OSC @100mV.
4. Measure Equipment:  
 L/Q: HP 4285A+HP 42841A(under 1MHz).L/Q: HP E4991A.(over 1MHz)  
 RDC: Chroma 16502 , or equivalent  
 SRF: Agilent E4991A+Agilent HP16197A or equivalent  
 I<sub>rms</sub>: HP4285A+HP42841A

AWVI00322522 Type

**Characteristics Graph**

**Inductance vs. Frequency Characteristics**

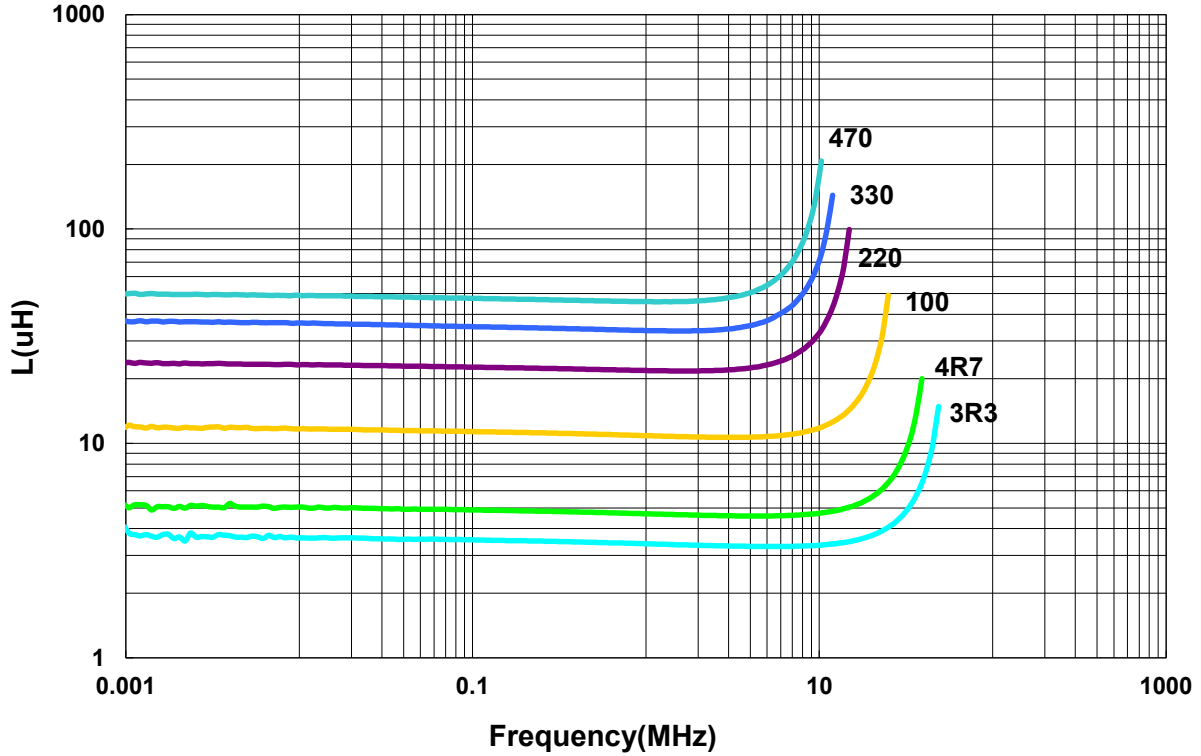

**Frequency vs. Q**

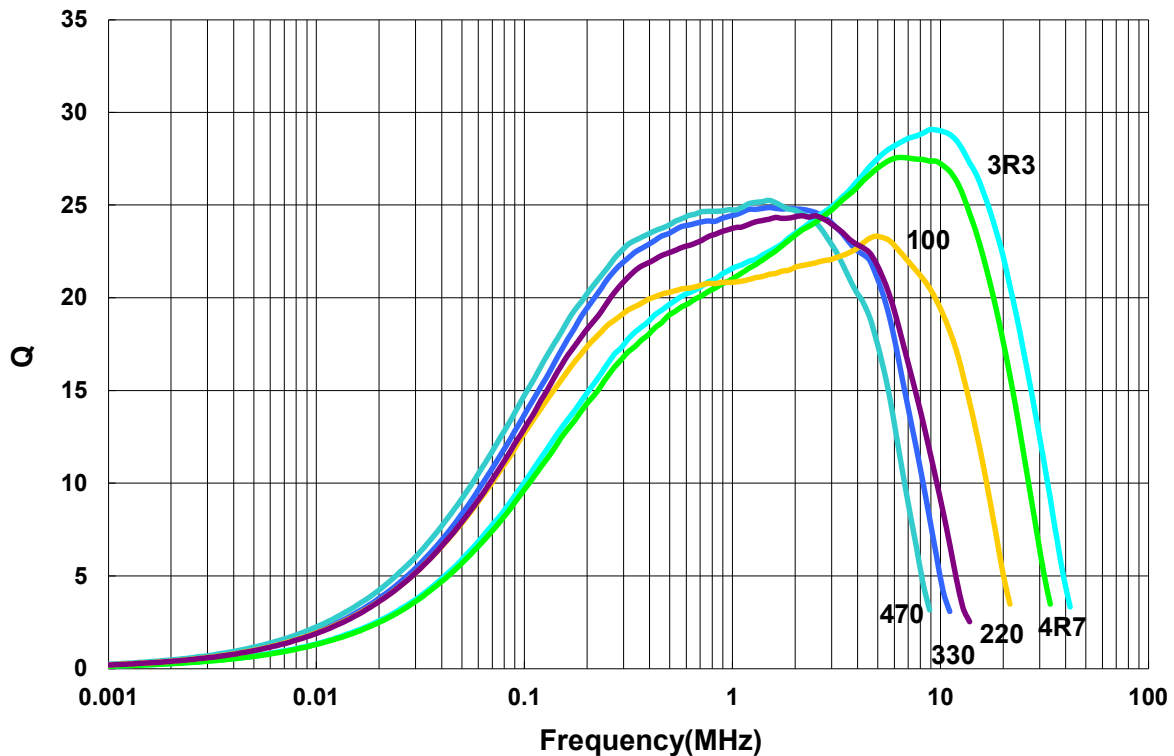

Please be sure to request approval specifications that provide further details of the products. Kindly note that the content of these specifications are subject to change or may be discontinued without prior notice. This product may not be designed/used in medical or high risk applications without Chilisin approval. Please contact our sales department before ordering.

**■ Packaging**

Tape Dimensions

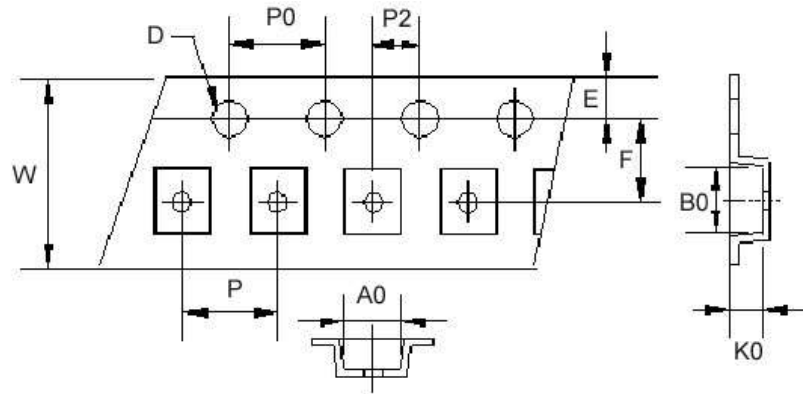

Reel Dimensions

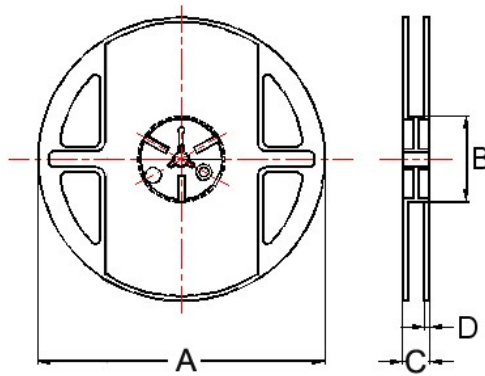

Dimensions in mm

TYPE	Tape Dimensions											Reel Dimensions				Quantity
	A0	B0	K0	D	E	F	W	P	P0	P2	A	B	C	D	PCS / Reel	
AWVI00322522	2.8	3.4	2.4	1.5	1.75	3.5	8	4	4	2	178	60	12	1.5	1000	

# Mouser Electronics

Authorized Distributor

Click to View Pricing, Inventory, Delivery & Lifecycle Information:

[Pulse:](#)

[BPPI00050525142X00](#)