

DATA SHEET

CURRENT SENSOR - LOW TCR

PE Series - Wide Terminal

5%, 1%, 0.5%

RoHS compliant & Halogen free



SCOPE

This specification describes PE series wide-terminal current sensor - low TCR chip resistors made by metal alloy process.

APPLICATIONS

- Battery pack
- Inverter/converter (DC-DC/AC-DC/DC-AC)
- Consumer electronics
- Laptops
- Automotive
- Alternative Energy

FEATURES

- AEC-Q200 qualified
- This product with lead-free terminations meet RoHS requirements
- High component and equipment reliability
- Ultra low resistance and narrow tolerance suitable for current detection

ORDERING INFORMATION - GLOBAL PART NUMBER

Global part numbers are identified by the series, size, tolerance, packing type, temperature coefficient, taping reel and resistance value.

GLOBAL PART NUMBER

PE XXXX X X X XX XXXX L
 (1) (2) (3) (4) (5) (6) (7)

(1) SIZE

0508/0612/0815

(2) TOLERANCE

D = ±0.5% (by request) F = ±1% J = ±5%

(3) PACKAGING TYPE

R = Paper taping reel
 K= Embossed taping reel

(4) TEMPERATURE COEFFICIENT OF RESISTANCE

E = ±50 ppm/°C
 M = ±75 ppm/°C
 F = ±100 ppm/°C
 L = ±150 ppm/°C

(5) TAPING REEL

07/7W = 7 inch dia. Reel and specific rated power. Detailed power ratings are shown in the Table 2

(6) RESISTANCE VALUE

0R001 (1 mΩ) ~ 1R (1Ω)

There are 3~5 digits indicated the resistance value. Letter R is decimal point.

(7) DEFAULT CODE

L = system default code for ordering only

ORDERING EXAMPLE

The ordering code of a PE0508 1W chip resistor, value 0.01 Ω with ±1% tolerance TCR ±75 ppm/°C, supplied in 7-inch tape reel with 5Kpcs quantity is: PE0508FRM070R01L.

NOTE

I. All our RSMD products are RoHS compliant. "LFP" of the internal 2D reel label mentions "Lead-Free Process"

MARKING

PE0508



Fig. 1 Value = 10 mΩ

No marking

PE0612/0815



Fig. 2 Value = 10 mΩ

4 digits

The "R" is used as a decimal point; the other 3 digits are significant.

CONSTRUCTION

The resistors are constructed using outstanding TCR level material, which makes Yageo PE resistors excellent for current sensing application.

The composition of the resistive material is adjusted to give the approximate required resistance and is covered with a protective coating. Marking is printed on the top side of the resistor.

Finally, the three external terminations (Cu / Ni / matte Tin) are added, as shown in Fig. 3.

Outlines

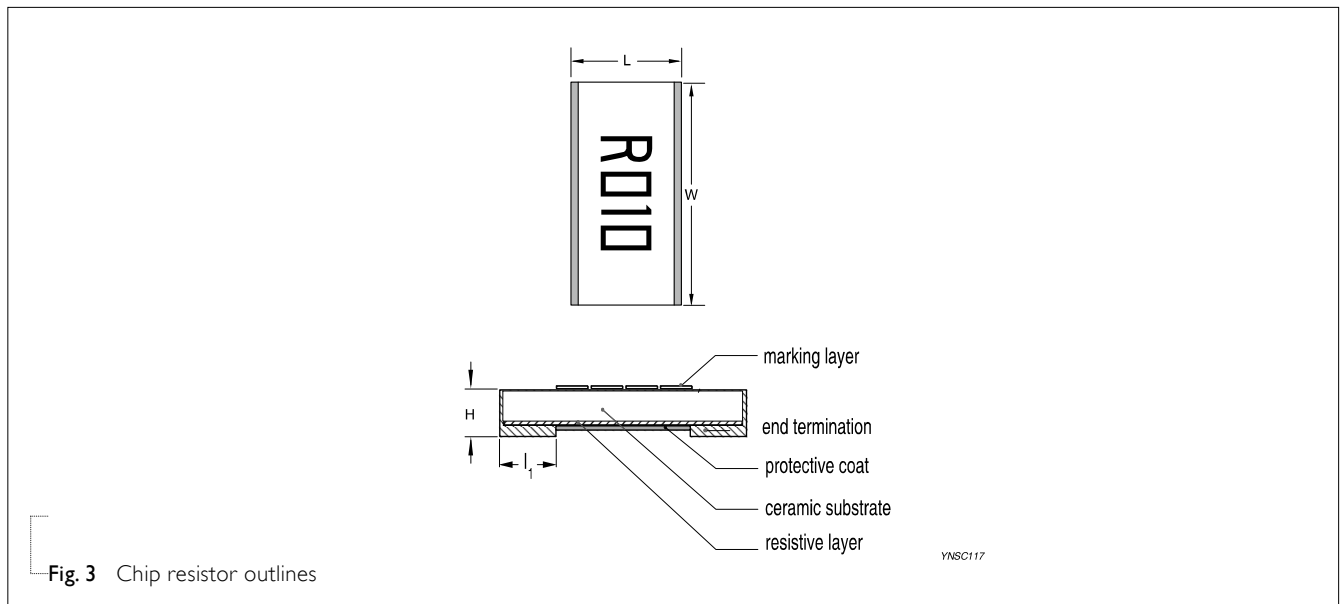

Fig. 3 Chip resistor outlines

YNSC117

DIMENSION

Table 1

TYPE	RESISTANCE RANGE	L (mm)	W (mm)	H (mm)	l ₁ (mm)
PE0508	5 mΩ ≤ R ≤ 1 Ω	1.25±0.10	2.00±0.10	0.55±0.15	0.35±0.15
	1 mΩ	1.60±0.20	3.20±0.20	0.60±0.15	0.55±0.20
PE0612	2 mΩ ≤ R ≤ 4 mΩ	1.60±0.20	3.20±0.20	0.60±0.15	0.40±0.15
	5 mΩ ≤ R ≤ 1 Ω	1.60±0.20	3.20±0.20	0.60±0.15	0.30±0.15
PE0815	1 mΩ ≤ R ≤ 2 mΩ	2.00±0.20	3.70±0.20	0.60±0.15	0.50±0.20
	3 mΩ ≤ R ≤ 20 mΩ	2.00±0.20	3.70±0.20	0.60±0.15	0.60±0.20

Note:

- For relevant physical dimensions, please refer to construction outlines.
- Please contact with sales offices, distributors and representatives in your region before ordering.

ELECTRICAL CHARACTERISTICS

Table 2

TYPE	POWER RATING ⁽¹⁾		TOLERANCE	RESISTANCE RANGE	TEMPERATURE COEFFICIENT OF RESISTANCE
	07	7W			
PE0508		---	± 0.5% (By request)	5 mΩ ≤ R < 75 mΩ	±100ppm/°C
				75 mΩ ≤ R ≤ 1 Ω	±50ppm/°C
PE0612		---	±1% ±5%	1 mΩ	±150ppm/°C
				2 mΩ	±100ppm/°C
				3 mΩ ≤ R ≤ 1 Ω	±50ppm/°C, ±75ppm/°C, ±100ppm/°C
PE0815	1/2W	1W		1 mΩ ≤ R ≤ 20 mΩ	±75ppm/°C ±100ppm/°C

Note: 1. Global part number (code 10 - 11)

- Please contact with sales offices, distributors and representatives in your region before ordering.

FUNCTIONAL DESCRIPTION

OPERATING TEMPERATURE RANGE

Range: -55°C to +155°C

POWER RATING

Standard rated power at 70°C:

PE0508 = 1W

PE0612 = 1W

PE0815 = 1/2W; 1W

RATED VOLTAGE

The DC or AC (rms) continuous working voltage corresponding to the rated power is determined by the following formula:

$$V = \sqrt{P \cdot R}$$

Where

V = Continuous rated DC or AC (rms) working voltage (V)

P = Rated power (W)

R = Resistance value (Ω)

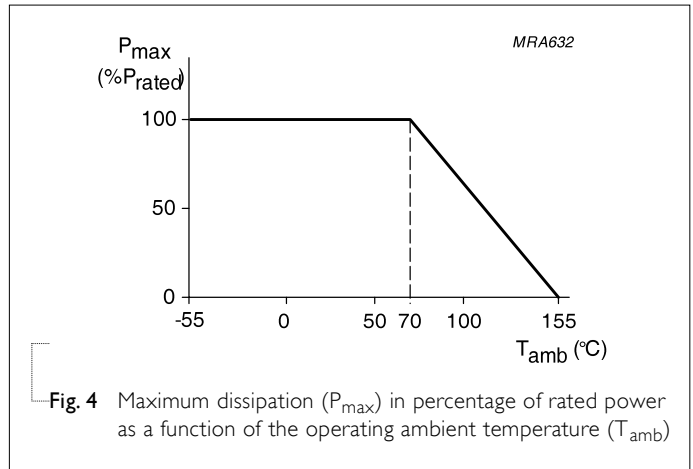

PACKING STYLE AND PACKAGING QUANTITY

Table 3 Packing style and packaging quantity

PACKING STYLE	REEL DIMENSION	PE0508	PE0612	PE0815
Paper taping reel (R)	7" (178 mm)	5,000	---	---
Embossed taping reel (K)	7" (178 mm)	---	5000	4000

PAPER TAPE

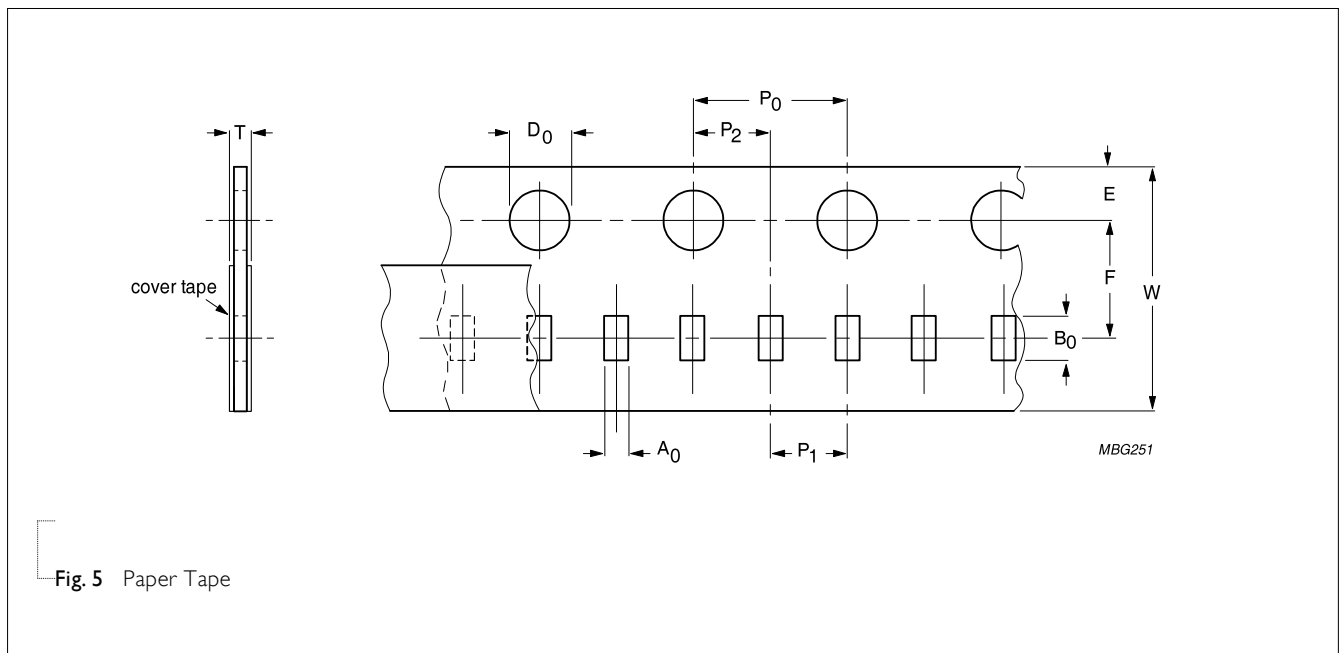

Fig. 5 Paper Tape

Table 4 Dimensions of paper tape for relevant chip resistors size

SIZE	SYMBOL										Unit: mm
	A ₀	B ₀	W	E	F	P ₀	P ₁	P ₂	ØD ₀	T	
PE0508	1.50± 0.15	2.25± 0.15	8.00±0.30	1.75±0.10	3.50±0.10	4.00±0.10	4.00±0.10	2.00±0.10	1.50±0.10	0.75± 0.15	

EMBOSSED TAPE

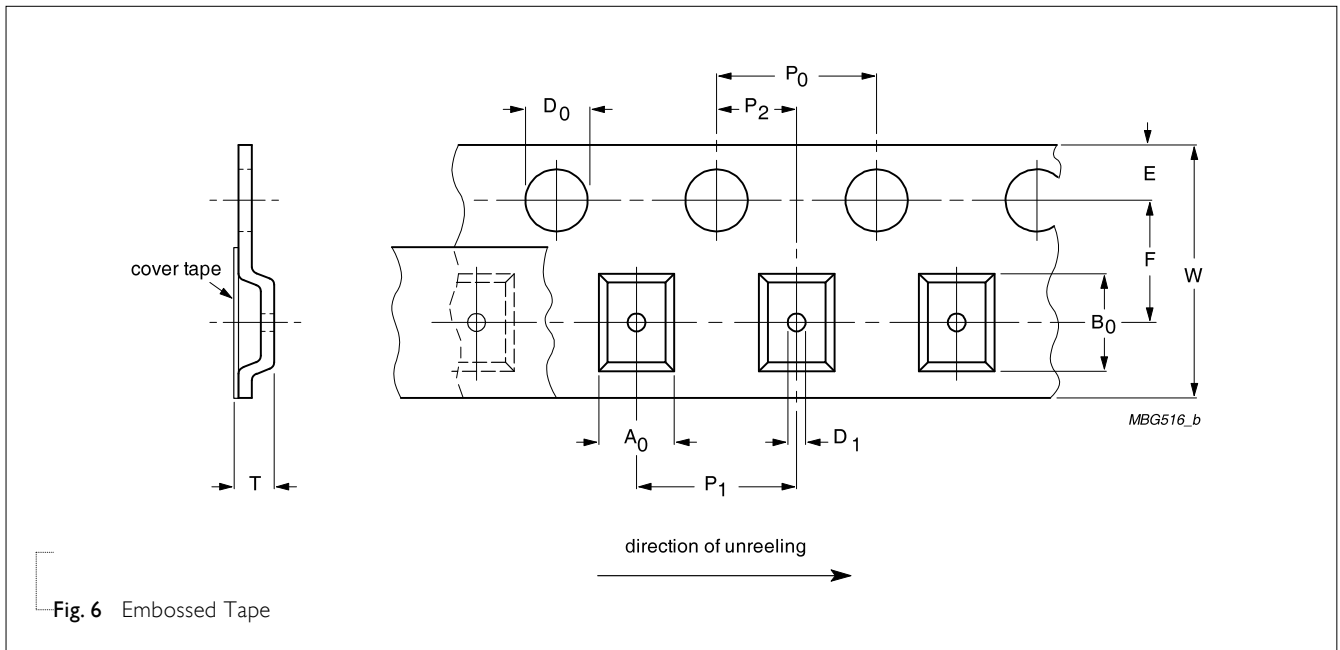

Fig. 6 Embossed Tape

Table 5 Dimensions of embossed tape for relevant chip resistors size

SIZE	SYMBOL											Unit: mm
	A ₀	B ₀	W	E	F	P ₀	P ₁	P ₂	ØD ₀	D ₁	T	
PE0612	1.80±0.15	3.52± 0.15	8.00±0.30	1.75±0.10	3.50±0.10	4.00±0.10	4.00±0.10	2.00±0.10	1.50±0.10	1.50±0.10	0.75± 0.15	
PE0815	2.25±0.15	4.00± 0.15	12.00±0.30	1.75±0.10	5.50±0.10	4.00±0.10	4.00±0.10	2.00±0.10	1.50±0.10	1.50±0.10	0.75± 0.15	

REEL SPECIFICATION

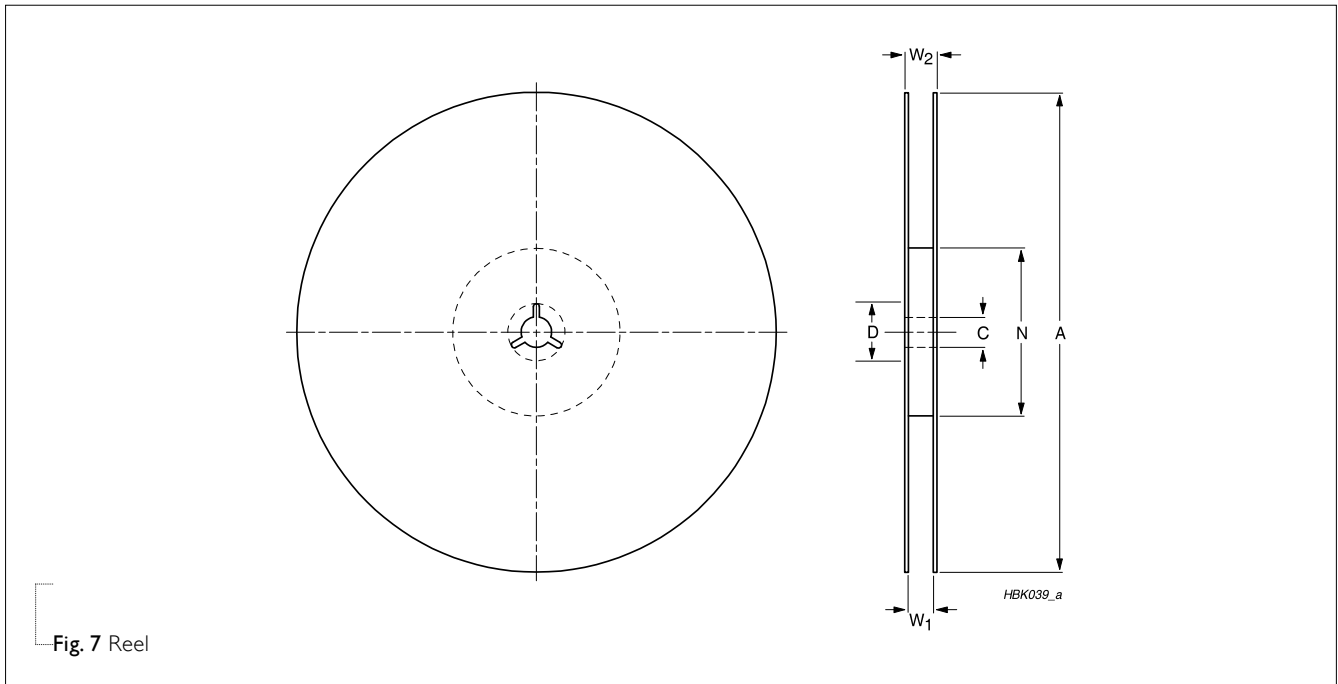

Fig. 7 Reel

Table 6 Dimensions of reel specification for relevant chip resistors size

SIZE	SYMBOL	Unit: mm					
		8 mm TAPE WIDE	A	N	C	D	W ₁
PE0508	7" (∅178 mm)	178.0±5	60.0+1/-0	13.00±0.5	17.70±0.5	8.4 +1/-0	12.4±1
PE0612	7" (∅178 mm)	178.0±5	60.0+1/-0	13.00±0.5	17.70±0.5	8.4 +1/-0	12.4±1

SIZE	SYMBOL	Unit: mm					
		12 mm TAPE WIDE	A	N	C	D	W ₁
PE0815	7" (∅178 mm)	178.0 ±5	60.0 +1/-0	13.00±0.5	17.70±0.5	12.3 +1/-0	18.4±1

SOLDERING PROFILES

For recommended soldering profiles, please refer to data sheet “Chip resistors mounting”.

FOOTPRINT

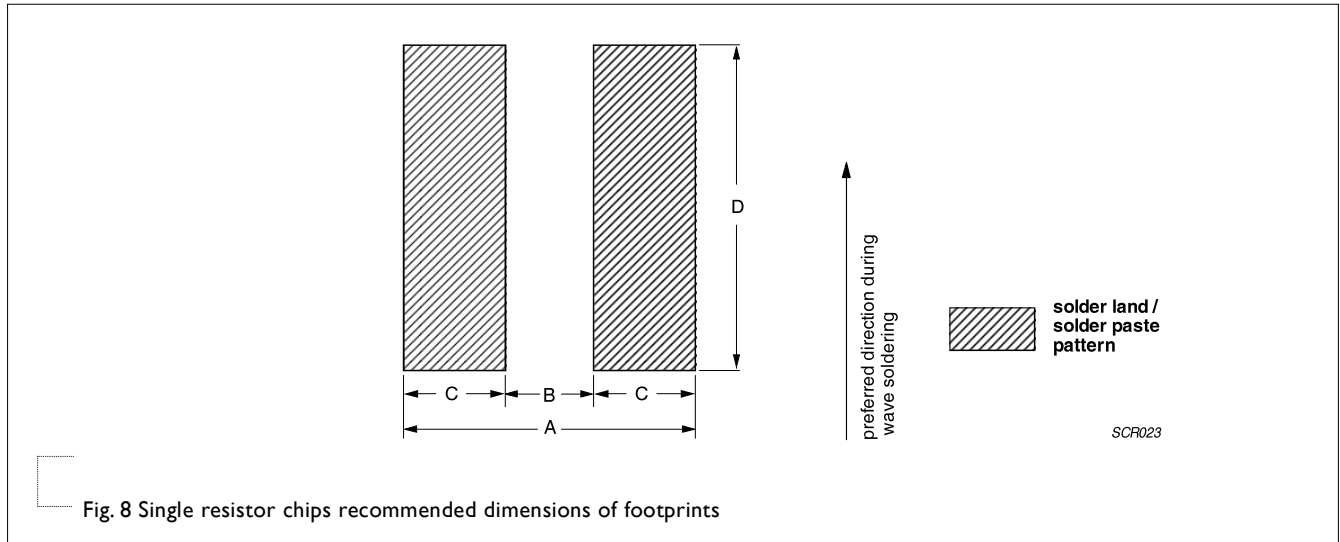

Table 7 Footprint dimensions

SIZE	RESISTANCE RANGE	Unit: mm			
		A	B	C	D
PE0508	$5\text{ m}\Omega \leq R \leq 1\Omega$	1.80~2.00	0.40~0.60	0.70	2.00
PE0612	$1\text{ m}\Omega \leq R \leq 4\text{m}\Omega$	4.60	0.40	2.10	3.68
	$5\text{ m}\Omega \leq R \leq 1\Omega$	4.60	0.60	2.00	3.68
PE0815	$1\text{m}\Omega \leq R \leq 20\text{m}\Omega$	3.38	0.58	1.40	4.20

TESTS AND REQUIREMENTS
Table 8 Test condition, procedure and requirements

TEST	TEST METHOD	PROCEDURE	REQUIREMENTS
Life/ Operational Life/ Endurance	IEC 60115-1 4.25.1	1,000 hours at 70±5 °C applied RCWV 1.5 hours on, 0.5 hour off, still air required	±(1%+0.0005 Ω)
High Temperature Exposure/ Endurance at Upper Category Temperature	IEC 60068-2-2	1,000 hours at maximum operating temperature depending on specification, unpowered No direct impingement of forced air to the parts Tolerances: 155±5 °C	±(1%+0.0005 Ω)
Moisture Resistance	MIL-STD-202 Method 106	Each temperature / humidity cycle is defined at 8 hours (method 106F), 3 cycles / 24 hours for 10d with 25 °C / 65 °C 95% R.H, without steps 7a & 7b, unpowered Parts mounted on test-boards, without condensation on parts Measurement at 24±2 hours after test conclusion	±(0.5%+0.0005 Ω)
Short Time Overload	IEC60115-1 4.13	5 times of rated power for 5 seconds at room temperature	±(0.5%+0.0005 Ω) No visible damage
Board Flex/ Bending	IEC60068-2-21	Device mounted on 90mm glass epoxy resin PCB test board (FR4), 2 mm bending Bending time: 60±5 seconds	±(1%+0.0005 Ω) No visible damage

TEST	TEST METHOD	PROCEDURE	REQUIREMENTS
Solderability - Wetting	J-STD-002B test B	Electrical Test not required Magnification 50X SMD conditions: 1 st step: method B, aging 4 hours at 155 °C dry heat 2 nd step: leadfree solder bath at 245±3 °C Dipping time: 3±0.5 seconds	Well tinned (≥95% covered) No visible damage
- Resistance to Soldering Heat	IEC 60068-2-58	Condition B, no pre-heat of samples Leadfree solder, 260 °C, 10±1 seconds immersion time Procedure 2 for SMD: devices fluxed and cleaned with isopropanol	±(0.5%+0.0005 Ω) No visible damage

REVISION HISTORY

REVISION	DATE	CHANGE NOTIFICATION	DESCRIPTION
Version 0	Dec. 03, 2018	-	- New datasheet for current sensor - low TCR wide terminal PE series with lead-free terminations.

“Yageo reserves all the rights for revising the content of this datasheet without further notification, as long as the products itself are unchanged. Any product change will be announced by PCN.”

Mouser Electronics

Authorized Distributor

Click to View Pricing, Inventory, Delivery & Lifecycle Information:

[YAGEO:](#)

[PE0612FKF070R033L](#)