

DATA SHEET

SURFACE MOUNT MULTILAYER CERAMIC CAPACITORS

Automotive grade
X5R/X6S

12 μ F to 1 μ F
RoHS compliant & Halogen Free



SCOPE

This specification describes Automotive grade X5R/X6S series chip capacitors with lead-free terminations and used for automotive infotainment system.

APPLICATIONS

Entertainment applications
Comfort applications
Information applications

Do not use these products in application critical to passenger safety and car driving function

FEATURES

- AEC-Q200 complaint
- MSL class: MSL I
- Soldering is compliant with J-STD-020D
- Reduce environmentally hazardous waste
- High component and equipment reliability
- The capacitors are 100% performed by automatic optical inspection prior to taping.

ORDERING INFORMATION - GLOBAL PART NUMBER

All part numbers are identified by the series, size, tolerance, TC material, packing style, voltage, process code, termination and capacitance value.

GLOBAL PART NUMBER

AC XXXX X X XXX X **B** X XXX
(1) (2) (3) (4) (5) (6) (7)

(1) SIZE – INCH BASED (METRIC)

0201 (0603) / 0402 (1005) / 0603 (1608) / 0805 (2012) / 1206 (3216)/ 1210 (3225)

(2) TOLERANCE

J = ±5%
K = ±10%
M = ±20%

(3) PACKING STYLE (SEE TABLE 5)

R = Paper/PE taping reel; Reel 7 inch
K = Blister taping reel; Reel 7 inch
P = Paper/PE taping reel; Reel 13 inch
F = Blister taping reel; Reel 13 inch

(4) TC MATERIAL

X5R
X6S

(5) RATED VOLTAGE

4 = 4 V
5 = 6.3 V
6 = 10 V
7 = 16 V
8 = 25 V
G = 35 V
9 = 50 V

(6) PROCESS

B = Class 2 MLCC

(7) CAPACITANCE VALUE

2 significant digits + number of zeros
The 3rd digit signifies the multiplying factor, and letter R is decimal point
Example: 121 = 12 × 10¹ = 120 pF

CONSTRUCTION

The capacitor consists of a rectangular block of ceramic dielectric in which a number of interleaved metal electrodes are contained. This structure gives rise to a high capacitance per unit volume.

The inner electrodes are connected to the two end terminations and finally covered with a layer of plated tin (Matte Sn). The terminations are lead-free. A cross section of the structure is shown in Fig.1.

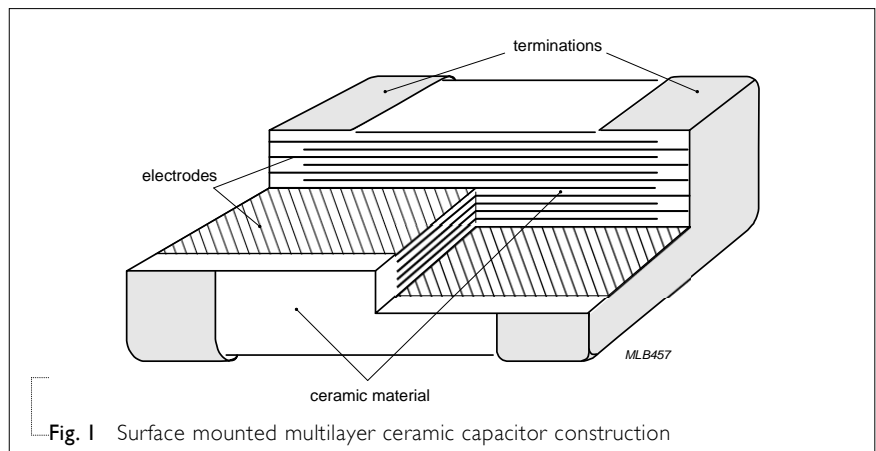

Fig. 1 Surface mounted multilayer ceramic capacitor construction

DIMENSION

Table I For outlines see fig. 2

TYPE	L ₁ (mm)	W (mm)	T (MM)	L ₂ / L ₃ (mm)		L ₄ (mm)
				min.	max.	min.
0201	0.6 ±0.03	0.3±0.03	0.3±0.03	0.10	0.20	0.20
0402	1.0 ±0.05	0.5 ±0.05	0.5 ±0.05	0.15	0.35	0.40
0603	1.6 ±0.10	0.8 ±0.10	0.8 ±0.10	0.20	0.60	0.40
0805	2.0 ±0.10	1.25 ±0.10	0.6 ±0.10	0.25	0.75	0.70
			0.85 ±0.10			
1206	3.2 ±0.15	1.6 ±0.15	0.6 ±0.10	0.25	0.75	1.40
			0.85 ±0.10			
			1.25 ±0.20			
1210	3.2 ±0.30	1.6 ±0.20	1.6 ±0.20	0.25	0.75	1.40
			1.6 ±0.30			
1210	3.2 ±0.30	2.5 ±0.20	0.85 ±0.10	0.25	0.75	1.40
			1.25 ±0.20			
	3.2 ±0.40	2.5 ±0.30	2.5 ±0.20			

OUTLINES

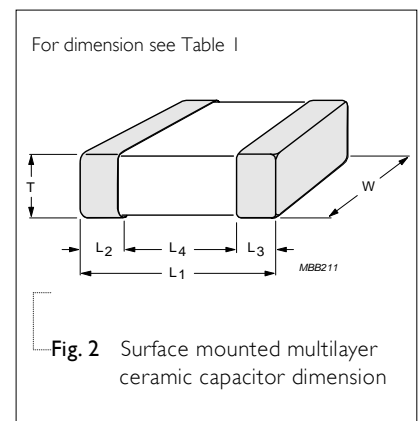

Fig. 2 Surface mounted multilayer ceramic capacitor dimension

CAPACITANCE RANGE & THICKNESS FOR X5R

Table 2 Sizes from 0201 to 0402

CAP.	0201		0402
	6.3V	10V	6.3 V
15 nF	0.3±0.03	0.3±0.03	
22 nF	0.3±0.03	0.3±0.03	
33 nF	0.3±0.03	0.3±0.03	
47 nF	0.3±0.03	0.3±0.03	
68 nF	0.3±0.03	0.3±0.03	
100 nF	0.3±0.03	0.3±0.03	
150 nF			0.5±0.05
220 nF			0.5±0.05
330 nF			0.5±0.05
470 nF			0.5±0.05
680 µF			0.5±0.05
1000 µF			0.5±0.05

NOTE

1. Values in shaded cells indicate thickness class in mm
2. Capacitance value of non E-6 series is on request

CAPACITANCE RANGE & THICKNESS FOR X6S

Table 3 Sizes 0201

CAP.	0201	
	6.3V	10V
15 nF	0.3±0.03	0.3±0.03
22 nF	0.3±0.03	0.3±0.03
33 nF	0.3±0.03	0.3±0.03
47 nF	0.3±0.03	0.3±0.03
68 nF	0.3±0.03	0.3±0.03
100 nF	0.3±0.03	0.3±0.03
150 nF		
220 nF		
330 nF		
470 nF		
680 µF		
1000 µF		

NOTE

1. Values in shaded cells indicate thickness class in mm
2. Capacitance value of non E-6 series is on request

THICKNESS CLASSES AND PACKING QUANTITY

Table 4

SIZE CODE	THICKNESS CLASSIFICATION	PACKING CODE		TAPE WIDTH	QUANTITY PER REEL			
		7 INCH	13 INCH		Ø180 MM / 7 INCH		Ø330 MM / 13 INCH	
					Paper	Blister	Paper	Blister
0201	0.3 ±0.03 mm	R	P	8 mm	15,000	---	50,000	---
0402	0.5 ±0.05 mm	R	P	8 mm	10,000	---	50,000	---
0603	0.8 ±0.1 mm	R	P	8 mm	4,000	---	15,000	---
0805	0.6 ±0.1 mm	R	P	8 mm	4,000	---	20,000	---
	0.85 ±0.1 mm	R	P	8 mm	4,000	---	15,000	---
	1.25 ±0.2 mm	K	F	8 mm	---	3,000	---	10,000
1206	0.6 ±0.1 mm	R	P	8 mm	4,000	---	20,000	---
	0.85 ±0.1 mm	R	P	8 mm	4,000	---	15,000	---
	1.0/1.15 ±0.1 mm	K	F	8 mm	---	3,000	---	10,000
	1.25 ±0.2 mm	K	F	8 mm	---	3,000	---	10,000
1210	0.85 ±0.1 mm	K	F	8 mm	---	4,000	---	10,000
	1.15 ±0.1 mm	K	F	8 mm	---	3,000	---	10,000
	1.25 ±0.2 mm	K	F	8 mm	---	3,000	---	10,000
	2.0 ±0.2 mm	K		8 mm	---	2,000	---	---
	2.5 ±0.2 mm	K		8 mm	---	1,000	---	---

PAPER/PE TAPE SPECIFICATION

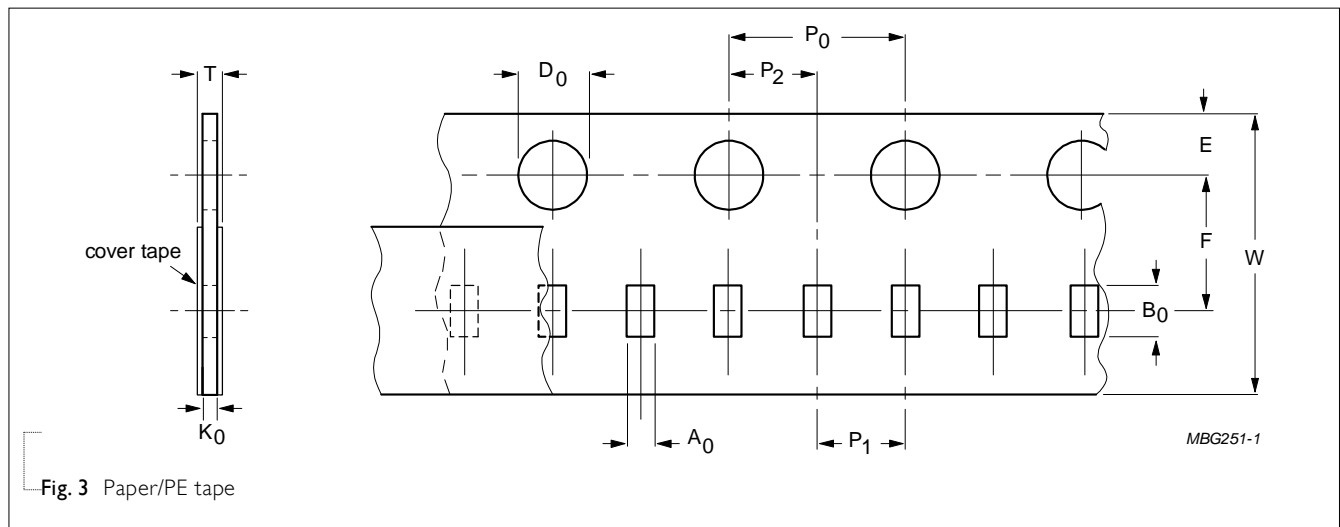

Fig. 3 Paper/PE tape

Table 5 Dimensions of paper/PE tape for relevant chip size; see Fig.3

SIZE	SYMBOL											Unit: mm
CODE	A ₀	B ₀	W	E	F	P ₀ ⁽¹⁾	P ₁	P ₂	ØD ₀	K ₀	T	
0201	0.39 ± 0.06	0.70 ± 0.06	8.0 ± 0.20	1.75 ± 0.1	3.50 ± 0.05	4.0 ± 0.05	2.0 ± 0.05	2.0 ± 0.05	1.55 ± 0.03	0.38 ± 0.05	(0.47 / 0.55)±0.10	
0402	0.70 ± 0.15	1.21 ± 0.12	8.0 ± 0.20	1.75 ± 0.1	3.50 ± 0.05	4.0 ± 0.05	2.0 ± 0.05	2.0 ± 0.05	1.50 +0.1 /-0	(0.75 / 0.60)±0.10	(0.85 / 0.70)±0.10	
0603	1.05 ± 0.14	1.86 ± 0.13	8.0 ± 0.20	1.75 ± 0.1	3.50 ± 0.05	4.0 ± 0.10	4.0 ± 0.10	2.0 ± 0.05	1.50 +0.1 /-0	(1.05 / 0.95 / 0.75)±0.10	(1.15 / 1.05 / 0.85)±0.10	
0805	1.50 ± 0.15	2.26 ± 0.20	8.0 ± 0.20	1.75 ± 0.1	3.50 ± 0.05	4.0 ± 0.10	4.0 ± 0.10	2.0 ± 0.05	1.50 +0.1 /-0	(1.05 / 0.95 / 0.75)±0.10	(1.15 / 1.05 / 0.85)±0.10	
1206	1.90 ± 0.15	3.50 ± 0.20	8.0 ± 0.20	1.75 ± 0.1	3.50 ± 0.05	4.0 ± 0.10	4.0 ± 0.10	2.0 ± 0.05	1.50 +0.1 /-0	(0.95 / 0.75)±0.10	(1.05 / 0.85)± 0.10	

NOTE

I. P₀ pitch tolerance over any 10 pitches is ±0.2 mm

BLISTER TAPE SPECIFICATION

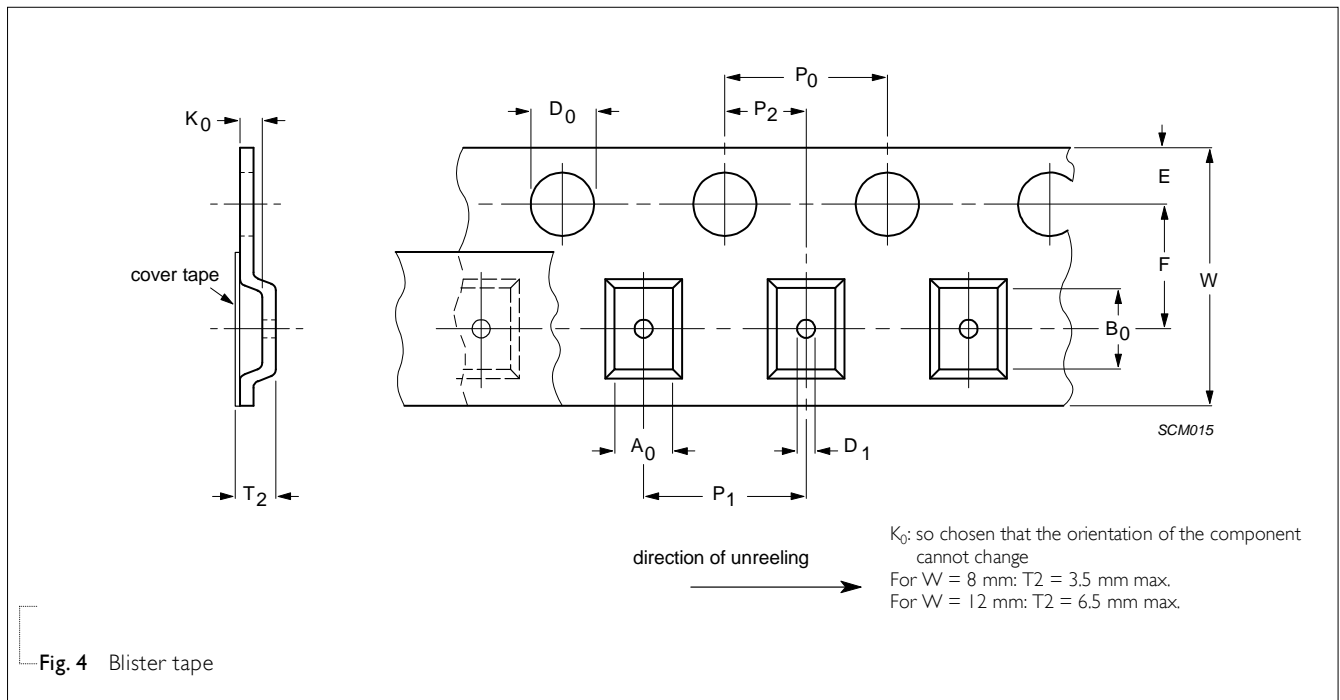

Fig. 4 Blister tape

Table 6 Dimensions of blister tape for relevant chip size; see Fig.4

SIZE CODE	SYMBOL												Unit: mm			
	A ₀		B ₀		K ₀		W	E	F	ØD ₀	ØD ₁	P ₀ ⁽²⁾	P ₁	P ₂	T ₂	
	Min.	Max.	Min.	Max.	Min.	Max.									Min.	Max.
0805	1.29	1.65	2.09	2.60	1.25	1.62	8.1 ±0.20	1.75 ±0.1	3.5 ±0.05	1.5 +0.1/-0.0	1 +0.1/-0.0	4.0 ±0.10	4.0 ±0.10	2.0 ±0.05	1.30	1.67
1206	1.65	2.12	3.30	3.75	1.22	2.15	8.1 ±0.20	1.75 ±0.1	3.5 ±0.05	1.5 +0.1/-0.0	1 +0.1/-0.0	4.0 ±0.10	4.0 ±0.10	2.0 ±0.05	1.27	2.20
1210	2.55	3.02	3.31	3.88	0.97	2.92	8.1 ±0.20	1.75 ±0.1	3.5 ±0.05	1.5 +0.1/-0.0	1 +0.1/-0.0	4.0 ±0.10	4.0 ±0.10	2.0 ±0.05	1.02	2.97

NOTE

1. Typical capacitor displacement in pocket
2. P₀ pitch tolerance over any 10 pitches is ±0.2 mm

REEL SPECIFICATION

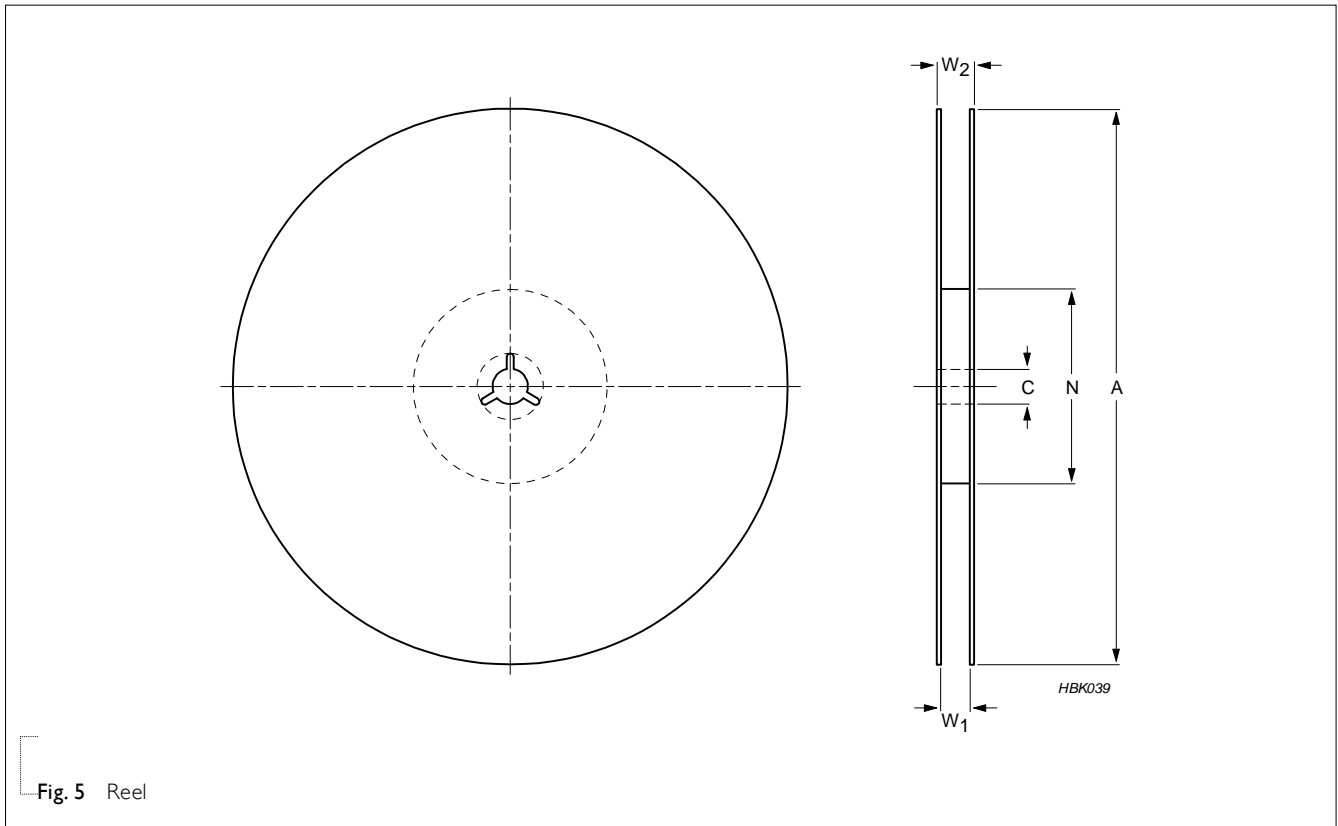

Fig. 5 Reel

Table 7 Reel dimensions; see Fig.5

TAPE WIDTH	SYMBOL			Unit: mm	
	A	N	C	W_1	$W_{2max.}$
8 (Ø178 mm/7")	178 ±1.0	60 ±1.0	13 +0.50/-0.20	9.4 ±1.5	14.4
8 (Ø330 mm/13")	330 ±1.0	100 ±1.0	13 +0.50/-0.20	9.0 ±0.2	14.4
12 (Ø178 mm/7")	178 ±1.0	60 ±1.0	13 +0.50/-0.20	13.4 ±1.5	18.4

PROPERTIES OF REEL

Material: polystyrene

Surface resistance: $<10^{10}$ Ω /sq.

ELECTRICAL CHARACTERISTICS

X5RX6S DIELECTRIC CAPACITORS; NI/SIN TERMINATIONS

Unless otherwise specified, all test and measurements shall be made under standard atmospheric conditions for testing as given in 5.3 of IEC 60068-1:

- Temperature: 15 °C to 35 °C
- Relative humidity: 25% to 75%
- Air pressure: 86 kPa to 106 kPa

Before the measurements are made, the capacitor shall be stored at the measuring temperature for a time sufficient to allow the entire capacitor to reach this temperature.

The period as prescribed for recovery at the end of a test is normally sufficient for this purpose.

DESCRIPTION

Table 8 **VALUE**

Capacitance tolerance X5R/X6S	±5% ⁽¹⁾ , ±10%, ±20%
----------------------------------	---------------------------------

Operating temperature range:	
X5R	-55 °C to +85 °C
X6S	-55 °C to +105 °C

Maximum capacitance change as a function of temperature (temperature characteristic/coefficient):	
X5R	±15%
X6S	±22%

Dissipation factor (D.F.)					
X5R	0201	0402	0603	0805	Spec.
6.3V	12nF to 100nF	120nF to 1µF			≤7%
10V	12nF to 100nF				≤10%
X6S	0201	0402			
6.3V	12nF to 100nF				≤10%
10V	12nF to 100nF				≤10%

Insulation resistance (I.R.)					
X5R	0201	0402	0603	0805	I.R. x C (Ω.F.)
					25°C Max. operating temperature
6.3V	12nF to 100nF	120nF to 1µF			≥100 ≥10
10V	12nF to 100nF				≥100 ≥10
X6S	0201	0402			
6.3V	12nF to 100nF				≥100 ≥10
10V	12nF to 100nF				≥100 ≥10

NOTE

1. Capacitance tolerance ±5% doesn't available for X5R/X6S full product range, please contact local sales force before order

SOLDERING RECOMMENDATION

Table 9

SOLDERING METHOD	SIZE					
	0201	0402	0603	0805	1206	≥ 1210
Reflow	Reflow only	≥ 0.1 μF	≥ 1.0 μF	≥ 2.2 μF	≥ 4.7 μF	Reflow only
Reflow/Wave		< 0.1 μF	< 1.0 μF	< 2.2 μF	< 4.7 μF	---

SOLDERING CONDITIONS

The lead free MLCCs are able to stand the reflow soldering conditions as below:

- Temperature: above 220 °C
- Endurance: 95 to 120 seconds
- Cycles: 3 times

The test of "soldering heat resistance" is carried out in accordance with the schedule of "MIL-STD-202G-method 210F", "The robust construction of chip capacitors allows them to be completely immersed in a solder bath of 260 °C for 10 seconds". Therefore, it is possible to mount MLCCs on one side of a PCB and other discrete components on the reverse (mixed PCBs). Surface Mount Capacitors are tested for solderability at 245 °C during 2 seconds. The test condition for no leaching is 260°C for 30 seconds.

TESTS AND REQUIREMENTS

Table 10 Test procedures and requirements

NO	AEC-Q2000 TEST	TEST METHOD	REQUIREMENTS
1	Pre-and Post-stress Electrical Test		
2	Temperature Cycling	Preconditioning: 150 +0/-10 °C for 1 hour, then keep for 24 ±1 hours at room temperature 1000 cycles with following detail: 15 minutes at -55 °C 15 minutes at 125 °C Recovery time 24 ±4 hours	No visual damage
			ΔC/C ±10%
			D.F. meet initial specified value
			I.R. meet initial specified value
3	Destructive Physical Analysis	Only applies to SMD ceramics. Electrical test not required.	

NO	AEC-Q2000 TEST	TEST METHOD	REQUIREMENTS
4	Humidity Bias	1. Preconditioning: 150 +0/-10 °C /1 hour, then keep for 24 ±1 hour at room temp 2. Initial measure: Parameter: I.R. Measuring voltage: 1.3V ± 1.5 Volts Note: Series with 100 KΩ 3. Test condition: 85 °C, 85% R.H. connected with 100 KΩ resistor, applied 1.5V/U _r for 1,000 hours. 4. Recovery: 24 ±2 hours 5. Final measure: C,D,I.R.	No visual damage after recovery
			ΔC/C ±15%
			D.F. Less than 200% of initial spec.
			I.R. The insulation resistance shall be greater than 10% of initial spec.
5	High Temperature Operational Life	1. Preconditioning: 150 +0/-10 °C /1 hour, then keep for 24 ±1 hour at room temp 2. Initial measure: Spec: refer to initial spec C, D, I.R. 3. Endurance test: Temperature: X5R:85 °C X6S:105 °C Specified stress voltage applied for 1,000 hours: Applied 100% U _r Recovery time: 24 ±2 hours Final measure: C, D, I.R. Note: If the capacitance value is less than the minimum value permitted, then after the other measurements have been made the capacitor shall be preconditioned according to "IEC 60384 4.1" and then the requirement shall be met.	No visual damage
			ΔC/C: ±20%
			D.F. Less than 200% of initial spec.
			I.R. The insulation resistance shall be greater than 10% of initial spec..
6	External Visual	Any applicable method using × 10 magnification	In accordance with specification
7	Physical Dimension	Verify physical dimensions to the applicable device specification.	In accordance with specification
8	Resistance to Solvents	1. Per MIL-STD-202 Method 215 2. Solvent 1 : 1 part (by volume) of isopropyl alcohol 3 parts (by volume) of mineral spirits 3. Solvent 2 : Terpene defluxer 4. Solvent 3 : 42 parts (by volume) of water 1 part (by volume) of propylene glycol monomethyl ether 1 part (by volume) of monoethanolamine	No visual damage
			ΔC/C ±10%
			D.F.: Within initial spec.
			I.R.: Within initial spec.

NO	AEC-Q2000 TEST	TEST METHOD	REQUIREMENTS
9	Mechanical Shock	Three shocks in each direction shall be applied along the three mutually perpendicular axes of the test specimen (18 shocks) Peak value: 1,500 g's Duration: 0.5 ms Velocity change: 15.4 ft/s Waveform: Half-sin	$\Delta C/C \pm 10\%$
			D.F. Within initial specified value
			I.R. Within initial specified value
10	Vibration	5 g's for 20 minutes, 12 cycles each of 3 orientations. 10-2000 Hz.	$\Delta C/C \pm 10\%$
			D.F: meet initial specified value
			I.R. meet initial specified value
11	Resistance to Soldering Heat	Precondition: 150 +0/-10 °C for 1 hour, then keep for 24 ± 1 hours at room temperature Preheating: for size ≤ 1206: 120 °C to 150 °C for 1 minute Preheating: for size > 1206: 100 °C to 120 °C for 1 minute and 170 °C to 200 °C for 1 minute Solder bath temperature: 260 ± 5 °C Dipping time: 10 ± 0.5 seconds Recovery time: 24 ± 2 hours	Dissolution of the end face plating shall not exceed 25% of the length of the edge concerned
			$\Delta C/C \pm 10\%$
			D.F. within initial specified value
12	ESD	Per AEC-Q200-002	A component passes a voltage level if all components stressed at that voltage level pass.

YNM0053-1

12

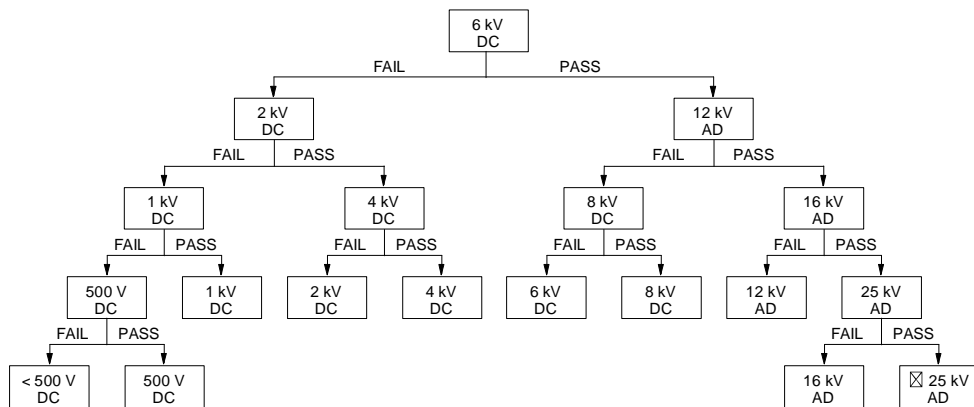

Note: Classify the components according to the highest ESD voltage level survived during ESD testing.

Fig. 7 Passive component HBM ESD test flow diagram (DC = Direct Contact Discharge, AD = Air Discharge)

NO	AEC-Q2000 TEST	TEST METHOD	REQUIREMENTS													
13	Solderability	<p>1. Preheat at 155°C for 4 hours. After preheating, immerse the capacitor in a solution of ethanol and rosin (25% rosin in weight proportion). Immerse in eutectic solder solution for 5+0/-0.5 seconds at 235±5°C.</p> <p>2. Should be placed into steam aging for 8 hours±15 minutes. After preheating, immerse the capacitor in a solution of ethanol and rosin (25% rosin in weight proportion). Immerse in eutectic solder solution for 5+0/-0.5 seconds at 235±5°C.</p> <p>3. Should be placed into steam aging for 8 hours±15 minutes. After preheating, immerse the capacitor in a solution of Ethanol and rosin (25% rosin in weight proportion). Immerse in eutectic solder solution for 30±5 seconds at 260±5°C.</p>	The solder should cover over 95% of the critical area of each termination.													
14	Electrical Characterization	Capacitance	At 25°C, 24 hours after annealing f = 1 KHz, measuring at voltage 1 Vrms at 25 °C													
		Dissipation Factor (D.F.)	At 25°C, 24 hours after annealing f = 1 KHz, measuring at voltage 1 Vrms at 25 °C	In according with specification on Table 8												
		Insulation Resistance (I.R.)	At Ur (DC) for 1 minute	In according with specification on Table 8												
		Temperature coefficient	<p>Capacitance shall be measured by the steps shown in the following table.</p> <p>The capacitance change should be measured after 5 min at each specified temperature stage.</p> <table border="1"> <thead> <tr> <th>Step</th> <th>Temperature(°C)</th> </tr> </thead> <tbody> <tr> <td>a</td> <td>25±2</td> </tr> <tr> <td>b</td> <td>Lower temperature±3°C</td> </tr> <tr> <td>c</td> <td>25±2</td> </tr> <tr> <td>d</td> <td>Upper Temperature±2°C</td> </tr> <tr> <td>e</td> <td>25±2</td> </tr> </tbody> </table> <p>Capacitance Change shall be calculated from the formula as below</p> $\Delta C = \frac{C2 - C1}{C1} \times 100\%$ <p>C1: Capacitance at step c C2: Capacitance at step b or d</p>	Step	Temperature(°C)	a	25±2	b	Lower temperature±3°C	c	25±2	d	Upper Temperature±2°C	e	25±2	<p>Δ C/C</p> <p>X5R: ±15%</p> <p>X6S: ±22%</p>
		Step	Temperature(°C)													
a	25±2															
b	Lower temperature±3°C															
c	25±2															
d	Upper Temperature±2°C															
e	25±2															
Voltage Proof	<p>1. Specified stress voltage applied for 1~5 seconds</p> <p>2. Ur ≤ 50 V: series applied 2.5 Ur</p> <p>Charge/Discharge current is less than 50 mA</p>	No breakdown or flashover														

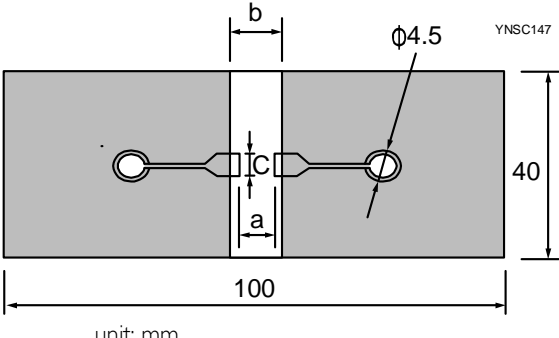
NO	AEC-Q2000 TEST	TEST METHOD	REQUIREMENTS																															
15	Board Flex	<p>Part mounted on a 100 mm X 40 mm FR4 PCB board, which is 1.6 ±0.2 mm thick and has a layer-thickness 35 μm ± 10 μm. Part should be mounted using the following soldering reflow profile. Conditions: Test Substrate:</p>  <p style="text-align: center;">unit: mm</p>	<p>No visible damage</p> <p>ΔC/C X5R/X6S: ±10%</p> <table border="1" data-bbox="1171 533 1445 833"> <thead> <tr> <th rowspan="2">Type</th> <th colspan="3">Dimension(mm)</th> </tr> <tr> <th>a</th> <th>b</th> <th>c</th> </tr> </thead> <tbody> <tr> <td>0201</td> <td>0.3</td> <td>0.9</td> <td>0.3</td> </tr> <tr> <td>0402</td> <td>0.4</td> <td>1.5</td> <td>0.5</td> </tr> <tr> <td>0603</td> <td>1.0</td> <td>3.0</td> <td>1.2</td> </tr> <tr> <td>0805</td> <td>1.2</td> <td>4.0</td> <td>1.65</td> </tr> <tr> <td>1206</td> <td>2.2</td> <td>5.0</td> <td>1.65</td> </tr> <tr> <td>1210</td> <td>2.2</td> <td>5.0</td> <td>2.0</td> </tr> </tbody> </table>	Type	Dimension(mm)			a	b	c	0201	0.3	0.9	0.3	0402	0.4	1.5	0.5	0603	1.0	3.0	1.2	0805	1.2	4.0	1.65	1206	2.2	5.0	1.65	1210	2.2	5.0	2.0
Type	Dimension(mm)																																	
	a	b	c																															
0201	0.3	0.9	0.3																															
0402	0.4	1.5	0.5																															
0603	1.0	3.0	1.2																															
0805	1.2	4.0	1.65																															
1206	2.2	5.0	1.65																															
1210	2.2	5.0	2.0																															
16	Terminal Strength	<p>With the component mounted on a PCB obtained with the device to be tested, apply a 17.7N (1.8Kg) force to the side of a device being tested. This force shall be applied for 60+1 seconds. Also the force shall be applied gradually as not to apply a shock to the component being tested. * Apply 2N force for 0402 size. * Apply 1N force for 0201 size.</p>	<p>Magnification of 20X or greater may be employed for inspection of the mechanical integrity of the device body, terminals and body/terminal junction. Before, during and after the test, the device shall comply with all electrical requirements stated in this specification.</p>																															

REVISION HISTORY

REVISION	DATE	CHANGE NOTIFICATION	DESCRIPTION
Version 0	Aug. 25, 2021	-	- New

“ YAGEO reserves all the rights for revising the content of this datasheet without further notification, as long as the products itself are unchanged. Any product change will be announced by PCN.”

LEGAL DISCLAIMER

YAGEO, its distributors and agents (collectively, "YAGEO"), hereby disclaims any and all liabilities for any errors, inaccuracies or incompleteness contained in any product related information, including but not limited to product specifications, datasheets, pictures and/or graphics. YAGEO may make changes, modifications and/or improvements to product related information at any time and without notice.

YAGEO makes no representation, warranty, and/or guarantee about the fitness of its products for any particular purpose or the continuing production of any of its products. To the maximum extent permitted by law, YAGEO disclaims (i) any and all liability arising out of the application or use of any YAGEO product, (ii) any and all liability, including without limitation special, consequential or incidental damages, and (iii) any and all implied warranties, including warranties of fitness for a particular purpose, non-infringement and merchantability.

YAGEO statements regarding the suitability of products for certain types of applications are based on YAGEO's knowledge of typical operating conditions for such types of applications in a generic nature. Such statements are neither binding statements of YAGEO nor intended to constitute any warranty concerning the suitability for a specific customer application or use. They are intended for use only by customers with requisite knowledge and experience for determining whether YAGEO products are the correct products for their application or use. In addition, unpredictable and isolated cases of product failure may still occur, therefore, customer application or use of YAGEO products which requires higher degree of reliability or safety, shall employ additional protective safeguard measures to ensure that product failure would not result in personal injury or property damage.

YAGEO products are not designed for application or use in medical, life-saving, or life-sustaining devices or for any other application or use in which the failure of YAGEO products could result in personal injury or death. Customers using or selling YAGEO products not expressly indicated for above-mentioned purposes shall do so at their own risk and agree to fully indemnify YAGEO and hold YAGEO harmless.

Information provided here is intended to indicate product specifications only. YAGEO reserves all the rights for revising this content without further notification, as long as products are unchanged. Any product change will be announced by PCN.

Mouser Electronics

Authorized Distributor

Click to View Pricing, Inventory, Delivery & Lifecycle Information:

YAGEO:

[AC0402KRX5R5BB105](#) [AC0402KRX5R5BB224](#) [AC0402KRX5R5BB474](#) [AC0201KRX6S5BB104](#)
[AC0201KRX6S6BB104](#) [AC0805KKX5R9BB225](#) [AC0201KRX5R6BB104](#) [AC0201KRX5R6BB223](#)