

Dim A = N × 3.5  
 Dim B = (N - 1) × 3.5

N = 1/2 Number of contacts

POLES	TOL
2×2p-2×6p	+0.15/-0.15
2×7p-2×12p	+0.20/-0.20
2×13p-2×18p	+0.25/-0.25
2×19p-2×24p	+0.30/-0.30

TECHNICAL CHARACTERISTICS

**MATERIAL**  
 INSULATOR: PA 66  
 FLAMABILITY RATING: UL94-V0  
 COLOR: GREEN  
 METAL HOUSING: BRASS (CuZn)  
 TERMINAL SCREW: STEEL ZINC PLATING "-" SLOT TYPE  
 WIRE GUARD: STAINLESS STEEL  
 SURFACE OF SOLDER TAIL PLATING: TIN

**ENVIRONMENTAL**  
 OPERATING TEMPERATURE: -40 UP TO 105°C  
 COMPLIANCE: LEAD FREE AND ROHS

**ELECTRICAL**  
 CURRENT RATING: 10A  
 WORKING VOLTAGE: 300VAC  
 WITHSTANDING VOLTAGE: 1.6KV  
 CONTACT RESISTANCE: 20 mOhm MAX

**STANDARD**  
 UL CERTIFIED E315414 / MODEL NUMBER 2301

**MECHANICAL**  
 SOLID WIRE: 24-16 AWG / 0.20-1.3MM<sup>2</sup>  
 STRANDED WIRE: 24-16 AWG / 0.20-1.3MM<sup>2</sup>  
 TORQUE: 1.7Lb.In / 0.2Nm

WIRE STRIPE LENGTH: 5-6mm  
 SCREW: M2  
 PITCH: 3.5.0mm

SOLDERING: WAVE PROCESS ONLY

PACKAGING: BOX

SERIE 2301

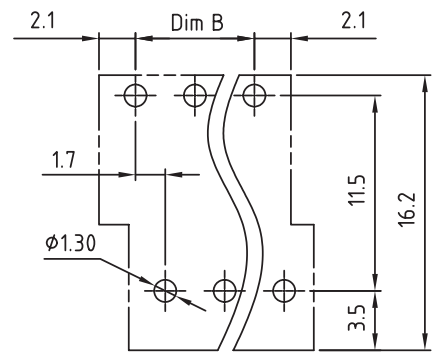
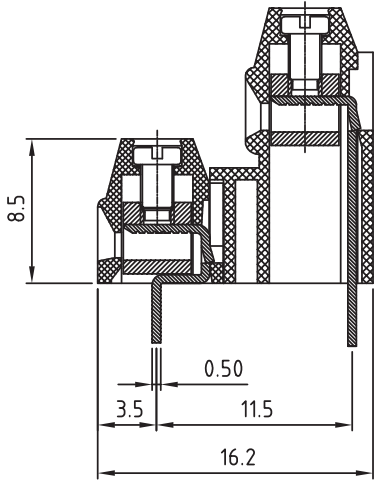
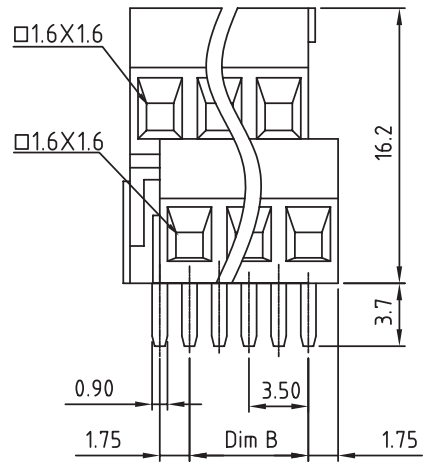

PCB LAYOUT - COMPONENT VIEW

RoHS Compliant			
G			
F			
E			
D			
C			
B			
A	08-JUN-10	PDF	JP
REV	DATE	FILE	BY

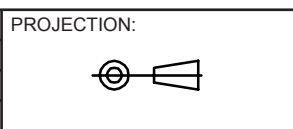

GENERAL TOLERANCE  
 .X = +/- 0.2  
 .XX = +/- 0.15



APPROVAL: RJ

UNIT: MM  
 SCALE:  
 SHEET: 1/1  
 DRAW: MARVIN

DESCRIPTION: SERIE 2301 - 3.5MM DOUBLE LEVEL HORIZONTAL ENTRY MODULAR WITH RISING CAGE - 1.3MM<sup>2</sup> WIRES WR-TBL  
 WERI PART NO: 691 230 110 0xx

SIZE  
**A4**

# Mouser Electronics

Authorized Distributor

Click to View Pricing, Inventory, Delivery & Lifecycle Information:

[Wurth Elektronik:](#)

[691230110004](#)