

WIMA DC-LINK HC

Preliminary!



Metallized Polypropylene (PP) - Capacitors for DC-Link Applications

Special Features

- Very high volume/capacitance ratio
- Self-healing, internal safety disconnecter
- Safe contact configurations by screwable plates
- Dry construction without electrolyte or oil
- Very low dissipation factor
- Negative capacitance change versus temperature
- Very low dielectric absorption
- According to RoHS 2011/65/EU
- Customer-specific capacitances or voltages on request

Typical Applications

As intermediate circuit capacitor e.g. in high power converter technology

Construction

Dielectric:

Polypropylene (PP) film

Capacitor electrodes:

Vacuum-deposited

Internal construction:

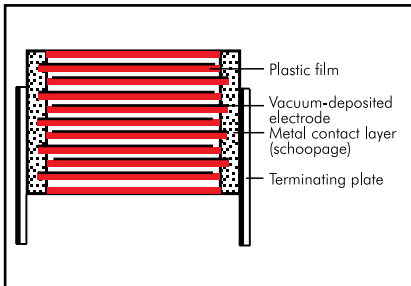

Encapsulation:

Solvent resistant, flame-retardant plastic case with resin seal and screw fixing, UL 94 V-0.

Terminations:

Tinned plates, customized plate configurations are possible.

Marking:

Colour: Black. Marking: Gold.

Electrical Data

Capacitance range:

340 μ F to 4500 μ F

Rated voltages:

400 VDC, 800 VDC

Capacitance tolerances:

$\pm 10\%$

Operating temperature:

-55° C to $+85^{\circ}$ C

Insulation resistance at $+20^{\circ}$ C:

$\geq 30\,000$ sec ($M\Omega \times \mu$ F)

(mean value: 100 000 sec)

Measuring voltage: 100 V/1 min.

Dissipation factors at $+20^{\circ}$ C:

See General Data.

Test voltage: 1.1 U_r , 2 sec

Dielectric absorption:

0.05 %

Voltage derating:

A voltage derating factor of 1.35 % per K must be applied from $+75^{\circ}$ C for DC voltages.

Reliability:

Operational life > 100 000 hours at 40° C

Failure rate < 36 fit ($10.75 \times U_r$ and 40° C)

Specific dissipation:

See General Data.

Mounting Recommendation

Excessive mechanical strain, e.g. pressure or shock onto the capacitor body, is to be avoided during mounting and usage of the capacitors. When fixing the capacitor the screw torque is to be limited to max. 5 Nm.

Packing

Transportation-safe packing in cardboard boxes.

For further details and graphs please refer to Technical Information.

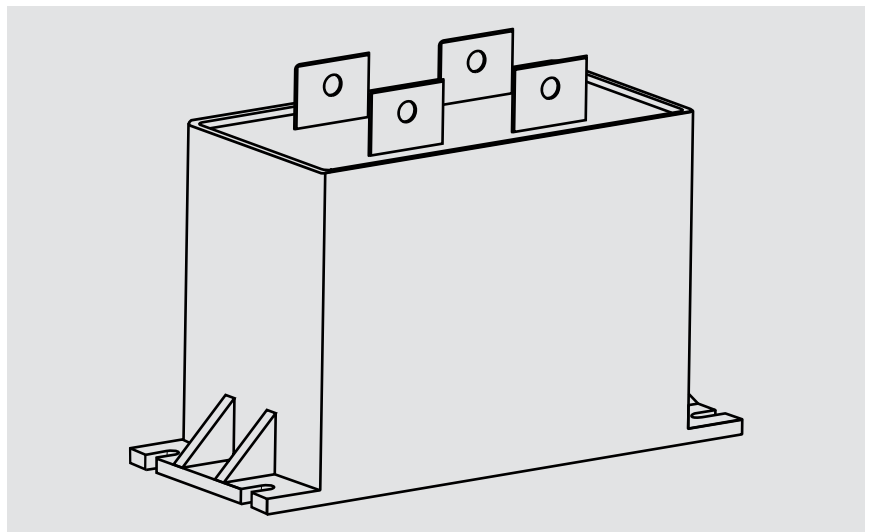

Continuation

General Data

Capacitance	400VDC								Part number
	W	H	L	I_{rms} (1 kHz)* A	ESR (1 kHz)* m Ω	k_T W/K	tan δ^* [x 10 ⁻⁴]		
							100 Hz	1 kHz	
500 μ F	94	49	182	65.4	1.43	0.613	8	45	DCH3G06250J000KS00
1000 "	94	77	182	103.5	0.72	0.767	8	45	DCH3G06500J100KS00
1500 "	94	105	182	139.0	0.48	0.922	8	45	DCH3G06750J200KS00
2000 "	94	133	182	173.3	0.36	1.076	8	45	DCH3G07100J300KS00
2500 "	94	161	182	196.7	0.32	1.231	11	50	DCH3G07125J400KS00
3000 "	94	189	182	228.5	0.27	1.385	11	50	DCH3G07150J500KS00
3500 "	94	217	182	248.1	0.25	1.540	11	55	DCH3G07175J600KS00
4000 "	94	245	182	278.3	0.22	1.695	14	55	DCH3G07200J700KS00
4500 "	94	285	182	298.7	0.21	1.893	14	60	DCH3G07225J800KS00

Capacitance	800VDC								Part number
	W	H	L	I_{rms} (1 kHz)* A	ESR (1 kHz)* m Ω	k_T W/K	tan δ^* [x 10 ⁻⁴]		
							100 Hz	1 kHz	
340 μ F	94	49	182	61.2	1.64	0.613	7	35	DCH4L06170J000KS00
680 "	94	77	182	96.8	0.82	0.767	7	35	DCH4L06340J100KS00
1020 "	94	105	182	129.9	0.55	0.922	7	35	DCH4L06510J200KS00
1360 "	94	133	182	162.1	0.41	1.076	7	35	DCH4L06680J300KS00
1700 "	94	161	182	181.3	0.37	1.231	10	40	DCH4L06850J400KS00
2040 "	94	189	182	210.7	0.31	1.385	10	40	DCH4L07102J500KS00
2380 "	94	217	182	226.2	0.30	1.540	10	45	DCH4L07119J600KS00
2720 "	94	245	182	253.7	0.26	1.695	12	45	DCH4L07136J700KS00
3060 "	94	285	182	269.8	0.26	1.893	12	50	DCH4L07153J800KS00

* General guide

Customized solutions can be realized on demand.

Interconnection.

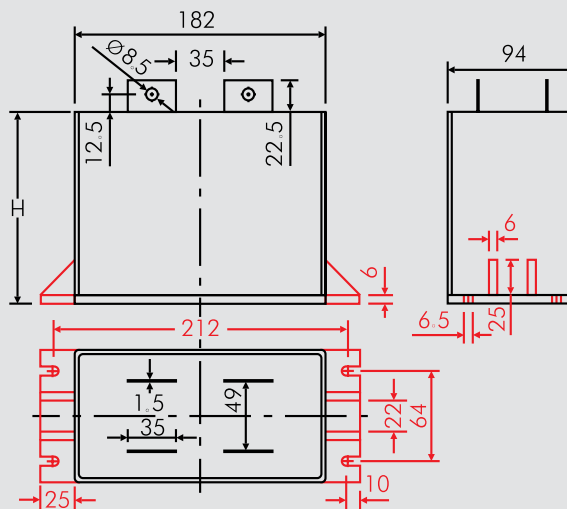
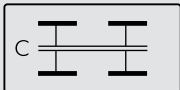

Rights reserved to amend design data without prior notification.



WIMA Part Number System

A WIMA part number consists of 18 digits and is composed as follows:

- Field 1 - 4: Type description
- Field 5 - 6: Rated voltage
- Field 7 - 10: Capacitance
- Field 11 - 12: Size and PCM
- Field 13 - 14: Version code (e.g. Snubber versions)
- Field 15: Capacitance tolerance
- Field 16: Packing
- Field 17 - 18: Pin length (untaped)

1	2	3	4	5	6	7	8	9	10	11	12	13	14	15	16	17	18
M	K	S	2	C	0	2	1	0	0	1	A	0	0	M	S	S	D
MKS 2				63 VDC		0.01 µF			2.5x6.5x7.2		-		20%	bulk	6-2		

<p>Type description:</p> <p>SMD-PET = SMDT SMD-PPS = SMDI FKP 02 = FKP0 MKS 02 = MKS0 FKS 2 = FKS2 FKP 2 = FKP2 MKS 2 = MKS2 MKS 2 = MKP2 FKS 3 = FKS3 FKP 3 = FKP3 MKS 4 = MKS4 MKP 4 = MKP4 MKP 10 = MKP1 FKP 4 = FKP4 FKP 1 = FKP1 MKP-X2 = MKX2 MKP-X2 R = MKXR MKP-Y2 = MKY2 MP 3-X2 = MPX2 MP 3-X1 = MPX1 MP 3-Y2 = MPY2 MP 3R-Y2 = MPRY Snubber MKP = SNMP Snubber FKP = SNFP GTO MKP = GTOM DC-LINK MKP 3 = DCP3 DC-LINK MKP 4 = DCP4 DC-LINK MKP 4S = DCPS DC-LINK MKP 5 = DCP5 DC-LINK MKP 6 = DCP6 DC-LINK HC = DCH_ DC-LINK HY = DCHY</p>	<p>Rated voltage:</p> <p>50 VDC = B0 63 VDC = C0 100 VDC = D0 250 VDC = F0 400 VDC = G0 450 VDC = H0 600 VDC = I0 630 VDC = J0 700 VDC = K0 800 VDC = L0 850 VDC = M0 900 VDC = N0 1000 VDC = O1 1100 VDC = P0 1200 VDC = Q0 1250 VDC = R0 1500 VDC = S0 1600 VDC = T0 2000 VDC = U0 2500 VDC = V0 3000 VDC = W0 4000 VDC = X0 6000 VDC = Y0 250 VAC = 0W 275 VAC = 1W 300 VAC = 2W 400 VAC = 3W 440 VAC = 4W 500 VAC = 5W ...</p>	<p>Capacitance:</p> <p>22 pF = 0022 47 pF = 0047 100 pF = 0100 150 pF = 0150 220 pF = 0220 330 pF = 0330 470 pF = 0470 680 pF = 0680 1000 pF = 1100 1500 pF = 1150 2200 pF = 1220 3300 pF = 1330 4700 pF = 1470 6800 pF = 1680 0.01 µF = 2100 0.022 µF = 2220 0.047 µF = 2470 0.1 µF = 3100 0.22 µF = 3220 0.47 µF = 3470 1 µF = 4100 2.2 µF = 4220 4.7 µF = 4470 10 µF = 5100 22 µF = 5220 47 µF = 5470 100 µF = 6100 220 µF = 6220 1000 µF = 7100 ...</p>	<p>Size:</p> <p>4.8x3.3x3 Size 1812 = KA 4.8x3.3x4 Size 1812 = KB 5.7x5.1x3.5 Size 2220 = QA 5.7x5.1x4.5 Size 2220 = QB 7.2x6.1x3 Size 2824 = TA 7.2x6.1x5 Size 2824 = TB 10.2x7.6x5 Size 4030 = VA 12.7x10.2x6 Size 5040 = XA 15.3x13.7x7 Size 6054 = YA 2.5x7x4.6 PCM 2.5 = 0B 3x7.5x4.6 PCM 2.5 = 0C 2.5x6.5x7.2 PCM 5 = 1A 3x7.5x7.2 PCM 5 = 1B 2.5x7x10 PCM 7.5 = 2A 3x8.5x10 PCM 7.5 = 2B 3x9x13 PCM 10 = 3A 4x9x13 PCM 10 = 3C 5x11x18 PCM 15 = 4B 6x12.5x18 PCM 15 = 4C 5x14x26.5 PCM 22.5 = 5A 6x15x26.5 PCM 22.5 = 5B 9x19x31.5 PCM 27.5 = 6A 11x21x31.5 PCM 27.5 = 6B 9x19x41.5 PCM 37.5 = 7A 11x22x41.5 PCM 37.5 = 7B 94x49x182 DCH_ = H0 94x77x182 DCH_ = H1 ...</p> <p>Version code:</p> <p>Standard = 00 Version A1 = 1A Version A1.1.1 = 1B Version A2 = 2A ...</p>	<p>Tolerance:</p> <p>±20% = M ±10% = K ±5% = J ±2.5% = H ±1% = E ...</p> <p>Packing:</p> <p>AMMO H16.5 340x340 = A AMMO H16.5 490x370 = B AMMO H18.5 340x340 = C AMMO H18.5 490x370 = D REEL H16.5 360 = F REEL H16.5 500 = H REEL H18.5 360 = I REEL H18.5 500 = J ROLL H16.5 = N ROLL H18.5 = O BLISTER W12 180 = P BLISTER W12 330 = Q BLISTER W16 330 = R BLISTER W24 330 = T Bulk/TPS Standard = S ...</p> <p>Pin length (untaped)</p> <p>3.5 ±0.5 = C9 6-2 = SD 16 ±1 = P1 ...</p>
---	--	---	--	--

The data on this page is not complete and serves only to explain the part number system. Part number information is listed on the pages of the respective WIMA range.

Mouser Electronics

Authorized Distributor

Click to View Pricing, Inventory, Delivery & Lifecycle Information:

[WIMA:](#)

[DCH4L07153J800KS00](#)