



# IQS222EV03 Evaluation Kit User Manual

IQ Switch® - ProxSense™ Series

## Table of Contents

1	INTRODUCTION.....	1
2	STANDALONE MODE.....	1
3	STREAMING MODE.....	2
4	REFERENCE DESIGN.....	3
5	PCB DESIGN.....	4

## 1 Introduction

This user manual describes the IQS222EV03 evaluation kit. The EV-kit is designed to function in two operational modes, standalone- and streaming-mode. It is developed to facilitate application engineers and development engineers in evaluating the IQS222 capacitive proximity and touch sensing capabilities, as well as

the 11-bit resolution of the scroll wheel and slider. LEDs are used to display the output of the channels in both standalone and streaming mode, while a GUI also allows streaming data to a PC, which facilitates adjusting all the device settings. The IQS222 comes complete in a Perspex® casing and carry bag.

## 2 Standalone Mode

Figure 2.1 shows the top view of the EV-kit. Its features include:

- Battery powered
- 5 x 10mm Diameter buttons
- Scroll Wheel
- Slider
- Quad 7-segment display for wheel/slider data (11-bit resolution)
- Buzzer for audio feedback
- 5 x Touch LEDs
- 1 x Proximity LED (for all channels)



Figure 2.1 Top-View of IQS222EV03 EV-kit board



### 3 Streaming Mode

The EV-kit board includes a mini-USB connector for streaming the IQS222 device to a PC. The GUI can set all the sensitivity settings for Proximity and Touch sensing. The GUI also includes an MP3 player for demonstrating the IQS222's promise in

electronic applications. For more details on using the GUI, please refer to application note: "AZD020-IQS222\_GUI\_Overview". The GUI is available on the Azoteq webpage: <http://www.azoteq.com>

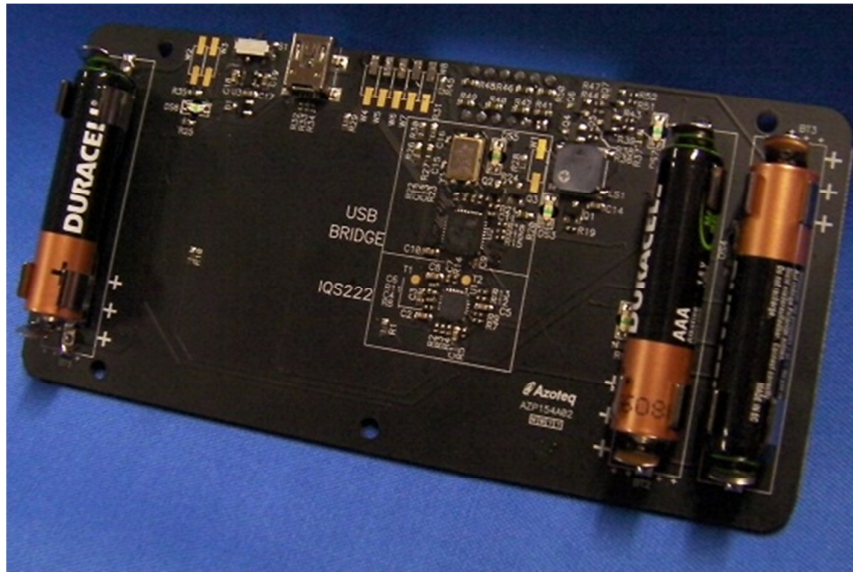

Figure 3.1 Back view of the IQS222 EV-kit board.



## 4 Reference Design

Figure 4.1 shows the reference design for the IQS222.

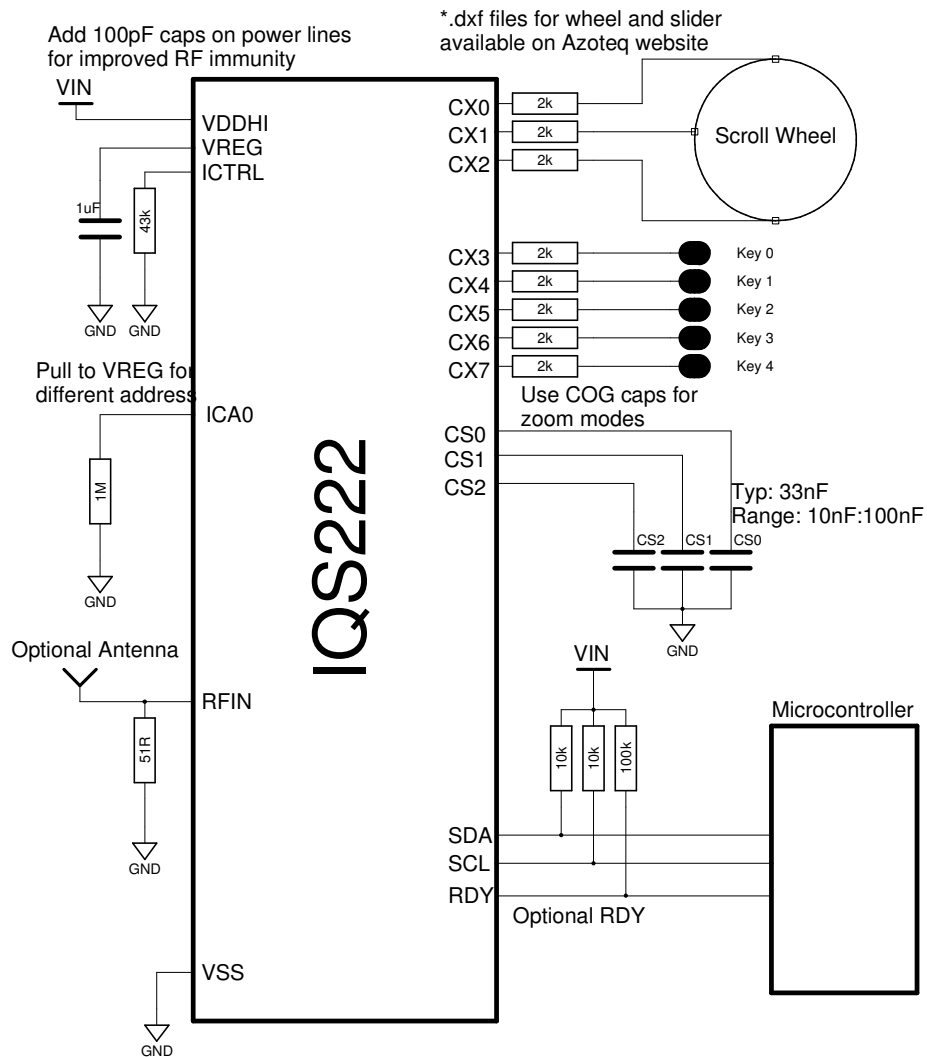

Figure 4.1 Reference Design for IQS222



## 5 PCB Design

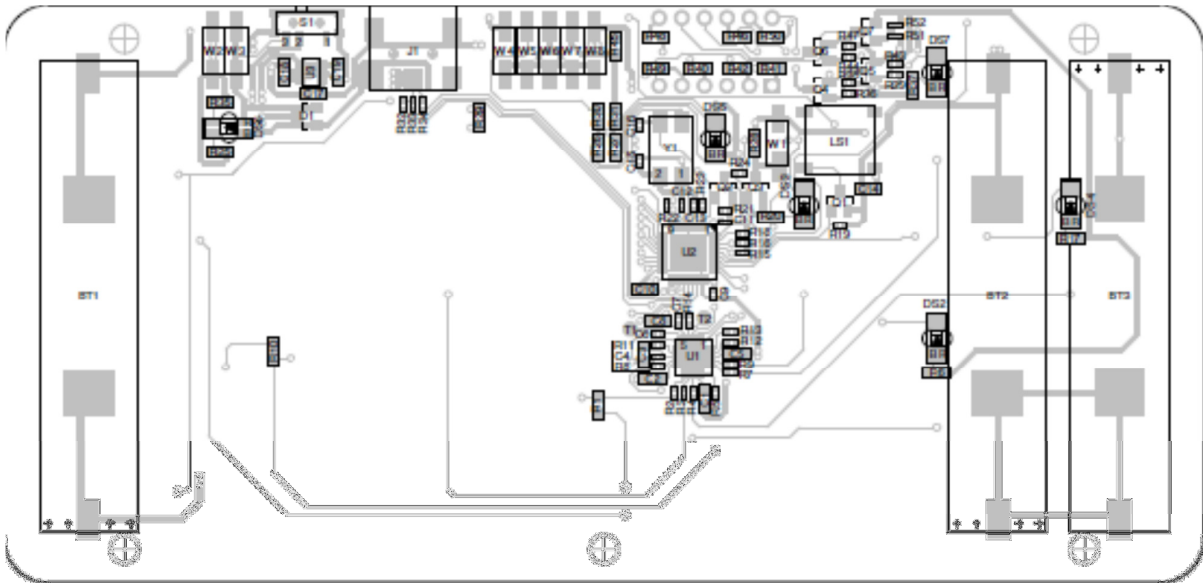

Figure 5.1 Bottom layer component placement

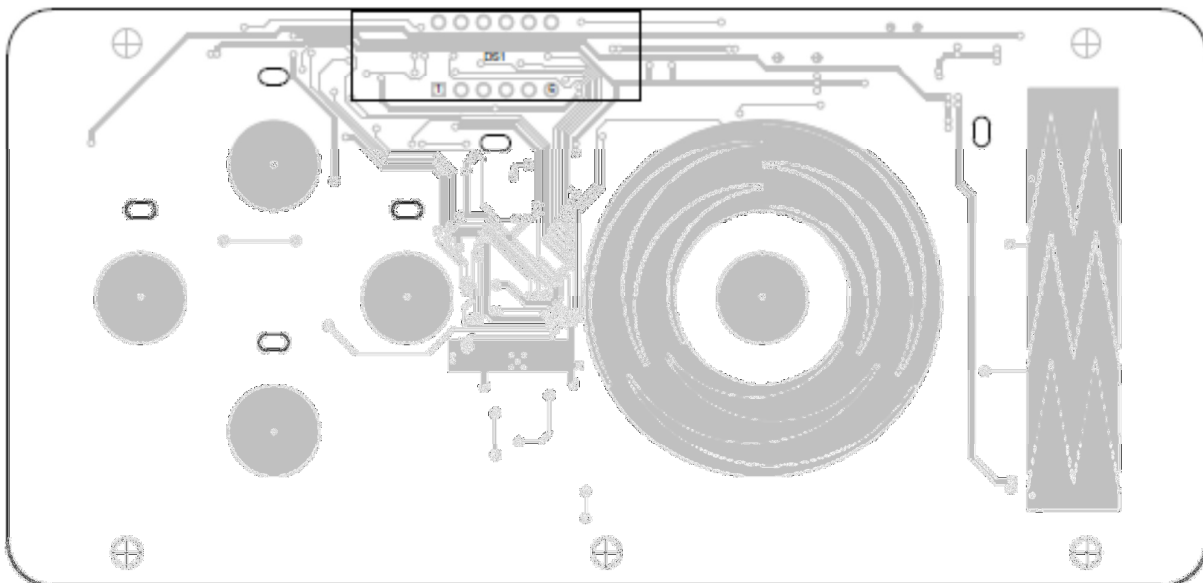



Figure 5.2 Top layer component placement



The following patents relate to the device or usage of the device: US 6,249,089 B1, US 6,621,225 B2, US 6,650,066 B2, US 6,952,084 B2, US 6,984,900 B1, US 7,084,526 B2, US 7,084,531 B2, US 7,119,459 B2, US 7,265,494 B2, US 7,291,940 B2, US 7,329,970 B2, US 7,336,037 B2, US 7,443,101 B2, US 7,466,040 B2, US 7,498,749 B2, US 7,528,508 B2, US 7,755,219 B2, US 7,772,781, US 7,781,980 B2, US 7,915,765 B2, EP 1 120 018 B1, EP 1 206 168 B1, EP 1 308 913 B1, EP 1 530 178 B1, ZL 99 8 14357.X, AUS 761094

IQ Switch®, ProxSense®, LightSense™, AirButton® and the  logo are trademarks of Azoteq.

The information in this Datasheet is believed to be accurate at the time of publication. Azoteq assumes no liability arising from the use of the information or the product. The applications mentioned herein are used solely for the purpose of illustration and Azoteq makes no warranty or representation that such applications will be suitable without further modification, nor recommends the use of its products for application that may present a risk to human life due to malfunction or otherwise. Azoteq products are not authorized for use as critical components in life support devices or systems. No licenses to patents are granted, implicitly or otherwise, under any intellectual property rights. Azoteq reserves the right to alter its products without prior notification. For the most up-to-date information, please refer to [www.azoteq.com](http://www.azoteq.com).

[WWW.AZOTEQ.COM](http://WWW.AZOTEQ.COM)

[ProxSenseSupport@azoteq.com](mailto:ProxSenseSupport@azoteq.com)

# Mouser Electronics

Authorized Distributor

Click to View Pricing, Inventory, Delivery & Lifecycle Information:

[Azoteq:](#)

[IQS222EV03S](#)