

PART NUMBER	REV	FIRST USED
680488-1	B	122500-1
680488-2	B	565435-5
680488-3	B	354500-1

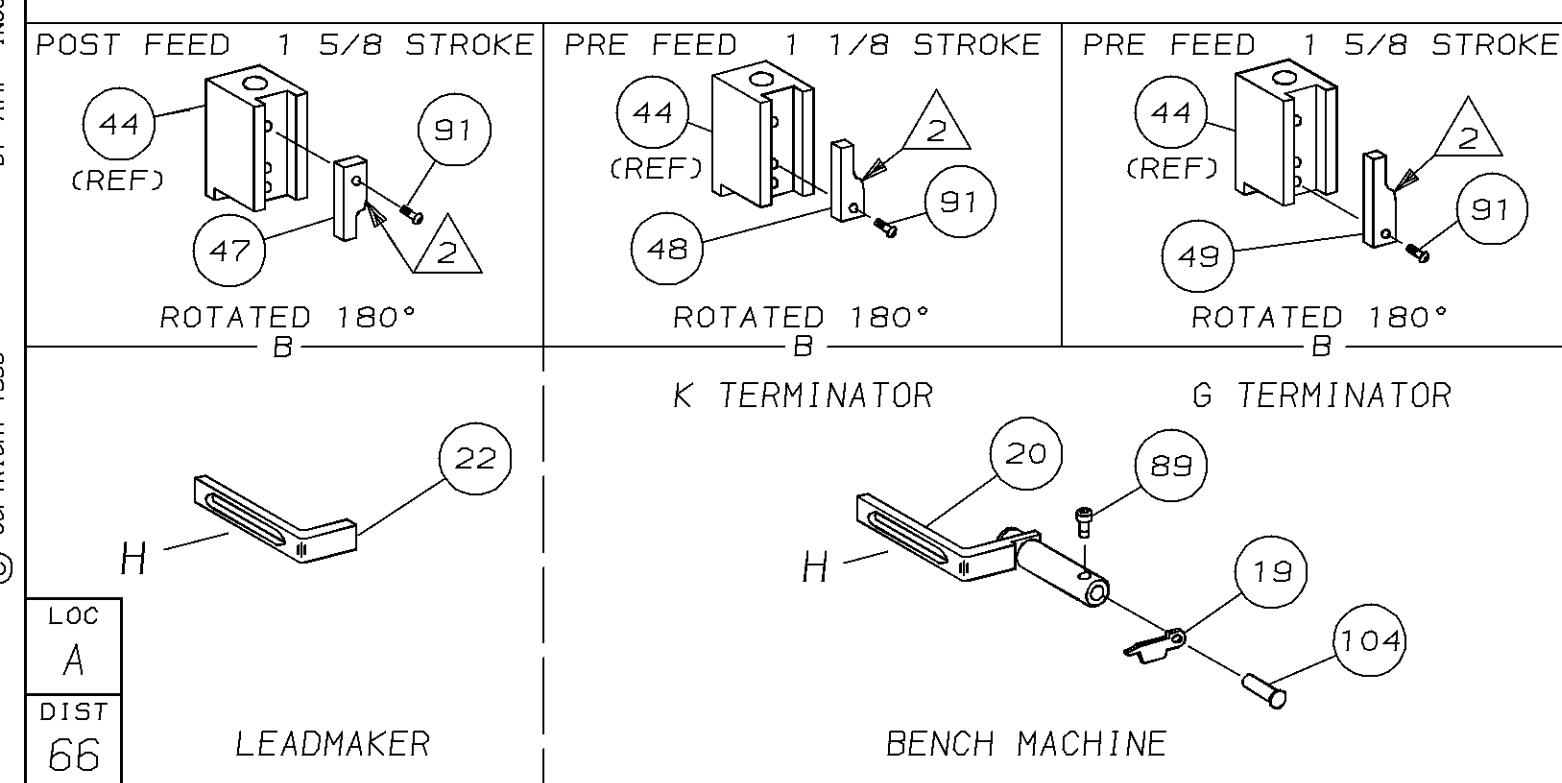
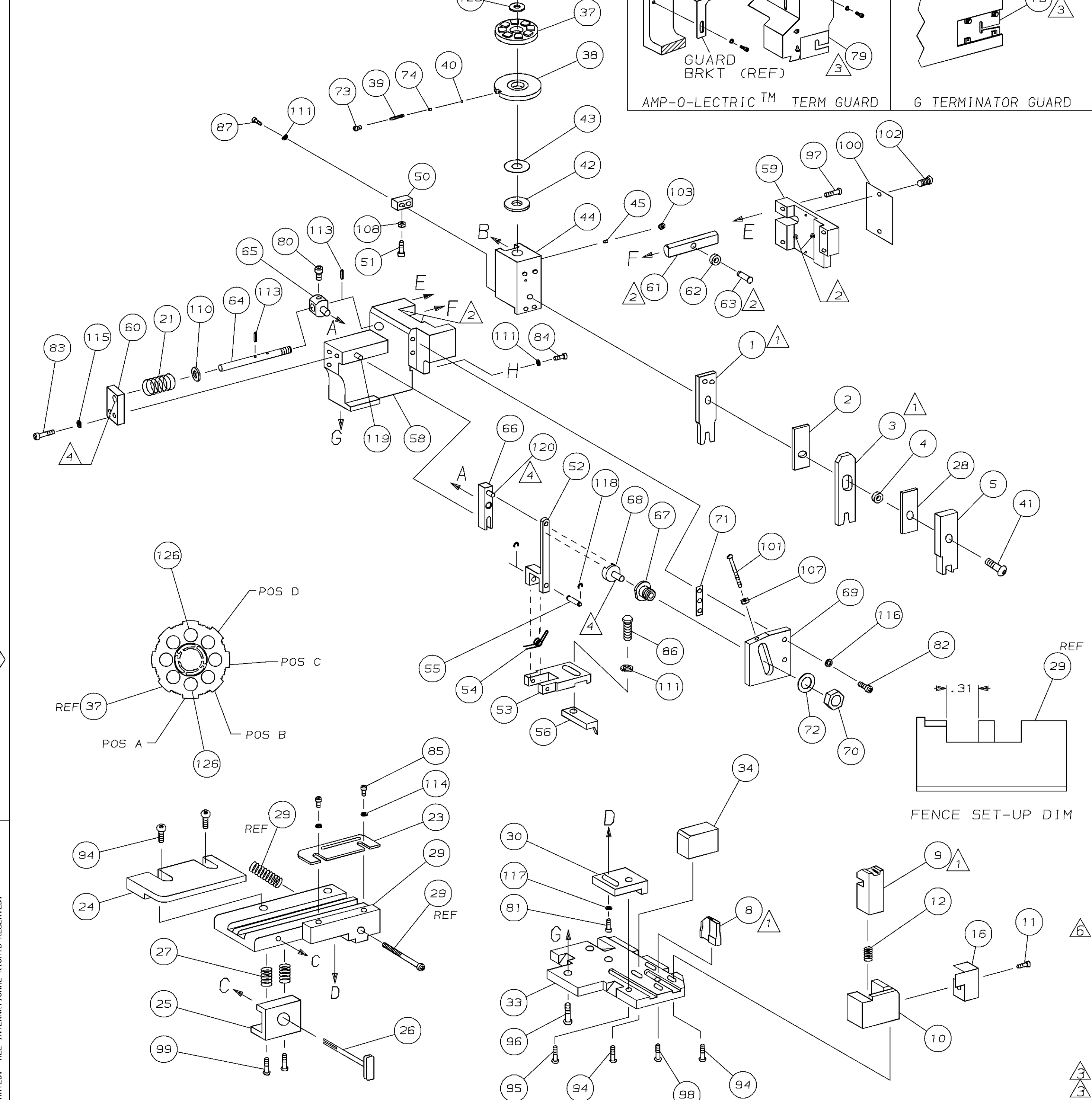

- 1 RECOMMENDED SPARE PARTS.
- 2 GREASE LIGHTLY.
- 3 GUARD MUST BE IN PLACE WHEN OPERATING APPLICATOR IN A BENCH MACHINE.
- 4 LUBRICATE DAILY USING NO. 20 MACHINE OIL.
- 5. ITEMS WITH QTY OF REF SPECIFIED (EXCEPT ITEMS 78 AND 79) ARE USED ON ITEM 46.
- 6 CUT TO LENGTH AT ASSY
- 7 GUIDE OFF INSULATION BARREL.

TERMINAL NAME: TERMINAL BLADE, FEMALE		CRIMPING DATA	
PAD LTR	CRIMP HEIGHT	WIRE SIZE	
A	.118 ±.002 [3.00 ±0.05mm]	8	
B	NOT	USED	
C	NOT	USED	
D	NOT	USED	
CRIMP	SIZE	TYPE RANGE	
WIRE	.190 [4.82mm]	F 8	
INSUL	.310 [7.87mm]	F Ø.157-.209	

QTY	REQD	PER	ASSY	TERM	APPL	SPEC	FEED	APPL	INSTRUCTION	SET UP	GAGE	LAYOUT
					NONE		.800		408-8040	458637-1		L1948
2	2	2	-	C								129
1	1	1	-	A								128
1	1	1	-	A								127
1	1	1	-	A								126
1	1	1	-	A								125
1	1	1	-	A								124
1	1	1	-	-								123
												122
												121
REF	REF	REF	-	A								120
REF	REF	REF	-	A								119
REF	REF	REF	-	A								118
1	1	1	-	A								117
REF	REF	REF	-	A								116
REF	REF	REF	-	A								115
2	2	2	-	A								114
REF	REF	REF	-	A								113
												112
4	4	4	-	A								111
REF	REF	REF	-	A								110
												109
1	1	1	-	A								108
REF	REF	REF	-	A								107
												106
												105
1	1	1	-	A								104
1	1	1	-	A								103
2	2	2	-	A								102
REF	REF	REF	-	A								101
1	1	1	-	B								100
2	2	2	-	A								99
1	1	1	-	A								98
REF	REF	REF	-	A								97
REF	REF	REF	-	A								96
REF	REF	REF	-	A								95
6	6	6	-	A								94
												93
												92
1	1	1	-	A								91
												90
1	1	1	-	A								89
												88
2	2	2	-	A								87
1	1	1	-	A								86
2	2	2	-	A								85
1	1	1	-	A								84
REF	REF	REF	-	A								83
REF	REF	REF	-	A								82
1	1	1	-	A								81
REF	REF	REF	-	A								80
-	REF	-	-	B								79
REF	-	-	-	B								78
												77
												76
												75
1	1	1	-	A								74
1	1	1	-	A								73
REF	REF	REF	-	A								72
REF	REF	REF	-	A								71
-3	-2	-1	U/M	DWG SIZE	PART NO	DESCRIPTION	ITEM NO					

LEADMAKER		MECH POST FEED	
-1	BENCH MODEL K	MECH PRE FEED	
-2	BENCH MODEL G	MECH PRE FEED	
REF	REF	REF	- B 22594-8 NUT, HEX (1/2-20) 70
REF	REF	REF	- B 240628-1 PLATE, ADJUSTMENT 69
REF	REF	REF	- B 240626-1 SHAFT, PIVOT 68
REF	REF	REF	- B 240633-1 BUSHING 67
REF	REF	REF	- A 455680-1 LEVER, INTERMEDIATE 66
REF	REF	REF	- B 240629-1 BLOCK, PIVOT 65
REF	REF	REF	- A 240632-2 SCREW, ADJ FEED ROD 64
REF	REF	REF	- B 240659-3 PIN, CAM ROLLER 63
REF	REF	REF	- B 240658-1 ROLLER, CAM 62
REF	REF	REF	- B 454398-2 ROD, FEED 61
REF	REF	REF	- A 454178-1 GUIDE, FEED ROD 60
REF	REF	REF	- C 454220-1 CAP, RAM 59
REF	REF	REF	- D 454485-1 HOUSING 58
			57
1	1	1	- B 1-694433-6 PAWL, FEED 56
REF	REF	REF	- B 240624-1 PIN, FEED FINGER 55
REF	REF	REF	- B 691499-1 SPRING, FEED FINGER 54
REF	REF	REF	- B 690541-1 HOLDER, FEED FINGER 53
REF	REF	REF	- A 455679-2 LEVER, TERMINAL FEED ARM 52
1	1	1	- A 811242-2 BUMPER, HOLDDOWN 51
1	1	1	- A 690753-1 SPACER, TONKER 50
1	-	-	- B 690602-6 CAM, PRE-FEED 1 5/8 ST 49
-	1	-	- B 690602-5 CAM, PRE-FEED 1 1/8 ST 48
-	-	-	- B 690501-4 CAM, POST-FEED 1 5/8 ST 47
1	1	1	- B 459456-2 APPLICATOR, BASIC (SUBASSY) 46
1	1	1	- A 690191-1 PLUG, NYLON 45
1	1	1	- C 819307-7 RAM 44
1	1	1	- A 690125-1 WASHER, LAMINATED 43
1	1	1	- A 690124-7 WASHER, RAM 42
1	1	1	- A 7-21002-9 BOLT, CRIMPER (5/16x1.00) 41
1	1	1	- A 23241-6 BALL, STEEL 40
1	1	1	- A 690170-1 SPRING, COMPRESSION 39
1	1	1	- C 690142-1 DISC, INSULATION 38
1	1	1	- D 354777-1 WIRE DISC, PLASTIC 37
1	1	1	- A 22480-5 WASHER, SPRING 36
1	1	1	- B 690212-1 POST, RAM 35
1	1	1	- B 690786-1 SUPPORT, TERMINAL 34
REF	REF	REF	- D 455675-1 PLATE, BASE 33
			32
			31
REF	REF	REF	- B 455689-1 BLOCK, STRIP GUIDE ADJ 30
1	1	1	- C 318042-1 STRIP GUIDE PLATE ASSY 29
1	1	1	- C 1-455888-6 SPACER, FRONT SHEAR DEP 28
2	2	2	- A 1-22284-0 SPRING, DRAG 27
1	1	1	- B 690546-1 LEVER, DRAG RELEASE 26
1	1	1	- B 240792-1 DRAG, TERMINAL 25
1	1	1	- D 1-90765-7 GUIDE, STRIP (REAR) 24
1	1	1	- A 690438-1 GUIDE, STRIP (FRONT) 23
-	-	-	- B 690472-2 STRIPPER 22
REF	REF	REF	- A 4-22284-9 SPRING, FEED RETURN 21
1	1	-	- A 679218-1 STRIPPER WIRE STOP ASSY 20
1	1	-	- B 458949-1 STRIPPER 19
			18
			17
1	1	1	- B 318563-1 GUARD, CHIP, FRONT 16
			15
			14
			13
1	1	1	- A 5-22280-0 SPRING, SHEAR 12
1	1	1	- B 690461-2 STOP, SHEAR 11
1	1	1	- C 1-690459-0 HOLDER, SHEAR (FRONT) 10
1	1	1	- C 454276-9 SHEAR, FLOAT (FRONT) 9
1	1	1	- C 1-318088-0 ANVIL 8
			7
			6
1	1	1	- C 1-455889-8 DEPRESSOR, SHEAR (FRONT) 5
1	1	1	- B 238011-2 SPACER, BLOCK CRIMPER 4
1	1	1	- C 3-456134-0 CRIMPER, INSULATION 3
1	1	1	- C 455888-9 SPACER, CRIMPER 2
1	1	1	- C 456429-5 CRIMPER, WIRE 1
-3	-2	-1	U/M DWG SIZE PART NO DESCRIPTION ITEM NO

REVISION OF EACH ASSY NO (WHEN BLANK, USE DWG REVISION)

QTY	REQD	PER	ASSY	PARTS LIST

DIMENSIONS IN INCHES. DO NOT SCALE PRINT. TOLERANCES UNLESS OTHERWISE SPECIFIED: 2 PLC DEC ±.02 3 PLC DEC ±.01 4 PLC DEC ±.005

REMOVE BURRS, BREAK SHARP EDGES R.015 MAX

MATL HT TR FIN

DR M. OBRINE 18JUN97 APP J. HIRNISEN 18JUN97
 CHK 18JUN97 REL 3/5/98 C. ERISMAN B. MORGAN

NAME SIDE FEED HDM APPLICATOR MACHINE REF MINI APPL
 SCALE DWG NO 680488 SHEET 1 OF 1 REV B

CAGE CODE 00779 CUSTOMER AND ASSEMBLY DRAWING RESTRICTED TO

THIS DRAWING IS A CONTROLLED DOCUMENT

THIS DRAWING IS UNPUBLISHED. RELEASED FOR PUBLICATION FEB 17, 1998 BY AMP INCORPORATED. ALL INTERNATIONAL RIGHTS RESERVED. © COPYRIGHT 1998

Mouser Electronics

Authorized Distributor

Click to View Pricing, Inventory, Delivery & Lifecycle Information:

[TE Connectivity:](#)

[680488-1](#)