

PART NUMBER	REV	FIRST USED
680446-1	A	122500-1
680446-2	A	565435-5
680446-3	A	354500-1

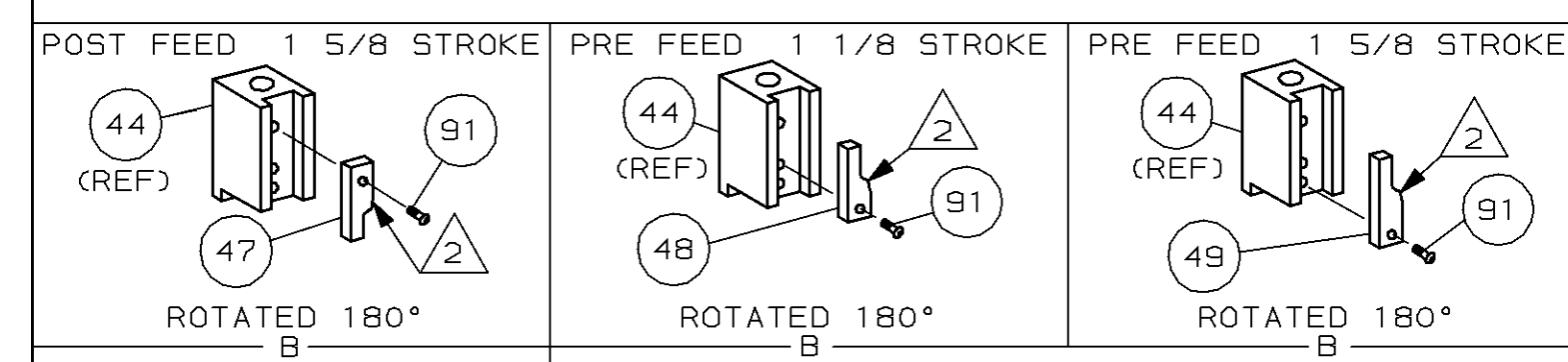
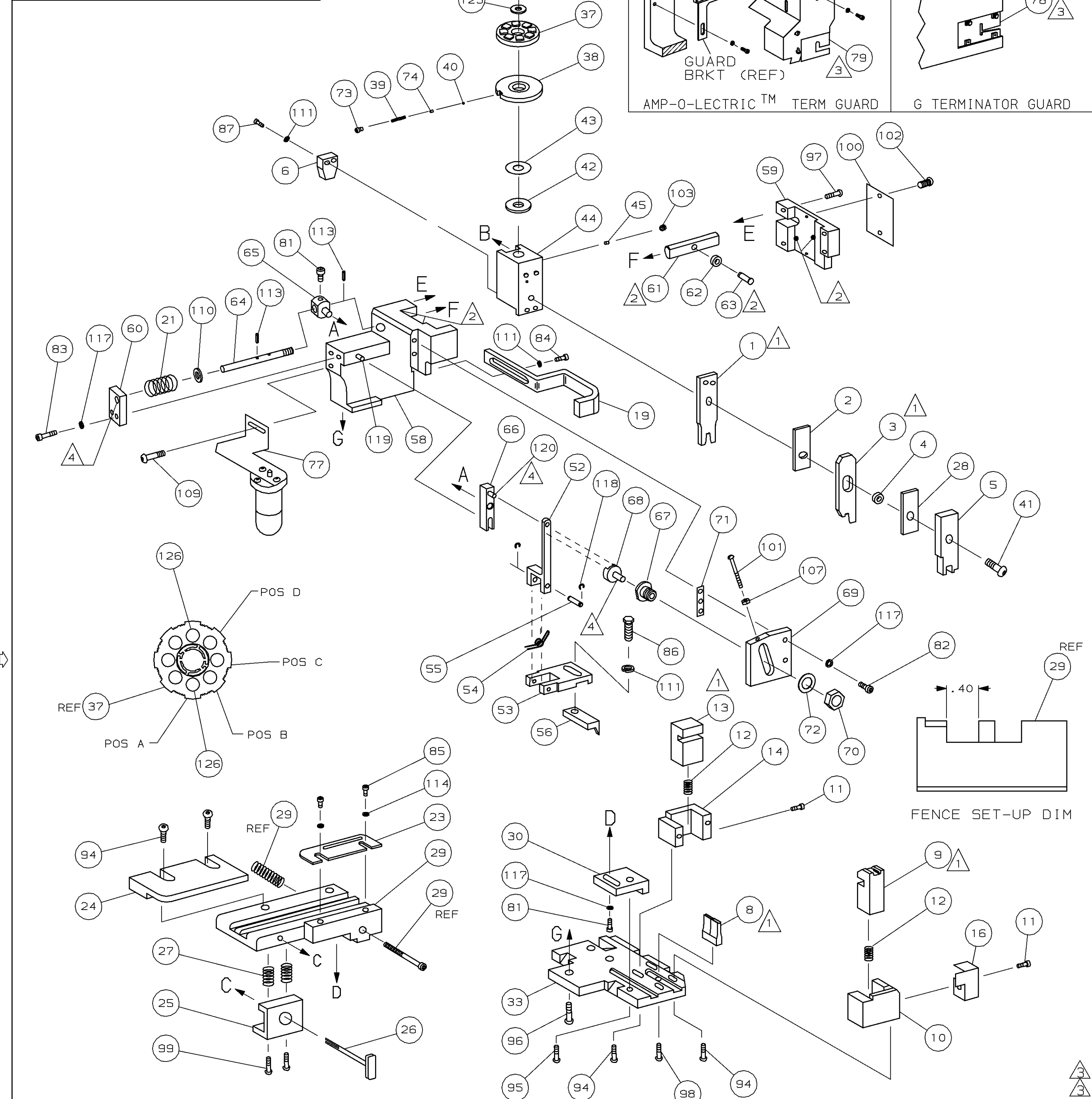

LOC	DIST	LEADMAKER	BENCH MACHINE
A	66		

- 1 RECOMMENDED SPARE PARTS.
- 2 GREASE LIGHTLY.
- 3 GUARD MUST BE IN PLACE WHEN OPERATING APPLICATOR IN A BENCH MACHINE.
- 4 LUBRICATE DAILY USING NO. 20 MACHINE OIL.
- 5 POSITION FEED FINGER ON OUTSIDE EDGE OF FRONT STRIP GUIDE PLATE.

TERMINAL NAME: TAB, .250 RIGHT ANGLE			
286569			
CRIMPING DATA			
PAD LTR	CRIMP HEIGHT	WIRE SIZE	
A	.095 ± 0.002 [2.41 ± 0.05mm]	18	
B	NOT	USED	
C	NOT	USED	
D	NOT	USED	
CRIMP	SIZE	TYPE	RANGE
WIRE	.130 [3.30mm]	F	18
INSUL	.160 [4.06mm]	0	φ.104

WIRE STRIP LENGTH	TERM APPL	SPEC	FEED	APPL INSTRUCTION	SET UP GAGE	LAYOUT
.219-.250	NONE		.900	408-8040	458637-1	L1902

QTY	REQD	PER	ASSY	PART NO	DESCRIPTION	ITEM NO	
1	1	1	-	A	1-21030-1	PIN, DOWEL (φ.187x.50) LEVER	120
1	1	1	-	A	1-21030-6	PIN, DOWEL (φ.187x1.25) HOUSING	119
2	2	2	-	A	21045-3	RING, RET "C" (φ.187) FD FING PIN	118
5	5	5	-	A	21024-5	WASHER, LOCK (#10) ADJ BLOCK	117
							116
							115
2	2	2	-	A	21024-2	WASHER, LOCK (#4) FRONT STP GUIDE	114
2	2	2	-	A	5-21028-1	PIN, SLT SPR (φ.125x.50) ADJ ROD	113
							112
4	4	4	-	A	21024-4	WASHER, LOCK (#8) STRIPPER	111
1	1	1	-	A	21899-4	WASHER, FLAT (φ5/16) SCREW ADJ	110
-	1	-	-	A	2-21002-6	SCR, BHC (10-32x.38) LUBE ASSY	109
							108
1	1	1	-	A	21018-5	NUT, HEX (6-32) FEED ADJ	107
							106
							105
							104
1	1	1	-	A	21009-2	SCR, SKT SET (1/4-20x.25 LW) RAM	103
2	2	2	-	A	21017-2	SCR, DRIVE (#2x.19) ID PLATE	102
1	1	1	-	A	6-23715-5	SCR, PAN HD (6-32x1.50) FEED ADJ	101
1	1	1	-	B	461264-1	PLATE, IDENTIFICATION	100
2	2	2	-	A	3-21002-0	SCR, BHC (10-32x.88) DRAG	99
1	1	1	-	A	22733-8	SCR, BHC (8-32x.38 LW) ANVIL	98
2	2	2	-	A	2-21002-9	SCR, BHC (10-32x.75) CAP	97
3	3	3	-	A	2-22733-8	SCR, BHC (1/4-20x.62) HOUSING	96
1	1	1	-	A	2-21002-7	SCR, BHC (10-32x.50) SG ADJ BLOCK	95
6	6	6	-	A	2-21002-2	SCR, BHC (8-32x.50) TERM H DWN	94
							93
							92
							91
1	1	1	-	A	1-21002-7	SCR, BHC (6-32x.38) CAM	90
							89
							88
2	2	2	-	A	2-21000-6	SCR, SHC (8-32x.38) DEP-HOLD	87
1	1	1	-	A	2-22603-0	SCR, HEX HD (8-32x.31) FEED FINGER	86
2	2	2	-	A	1-21000-3	SCR, SHC (4-40x.25) F ST GUIDE	85
1	1	1	-	A	2-21000-7	SCR, SHC (8-32x.50) STRIPPER	84
2	2	2	-	A	3-21000-7	SCR, SHC (10-32x.75) FEED ROD GD	83
2	2	2	-	A	3-21000-6	SCR, SHC (10-32x.62) FEED ADJ BLK	82
2	2	2	-	A	3-21000-4	SCR, SHC (10-32x.38) SG ADJ BL	81
							80
-	REF	-	-	B	455749-1	GUARD, WINDOW	79
REF	-	-	-	B	679532-1	INSERT, GUARD	78
-	1	-	-	C	1-465184-0	LUBRICATOR ASSY	77
							76
							75
1	1	1	-	A	690603-1	SPRING, ASSIST	74
1	1	1	-	A	23030-1	SCR, SHC (6-32x.25 SL) INS DISC	73
1	1	1	-	A	458109-1	WASHER, SPECIAL	72
1	1	1	-	A	690517-1	SPACER	71
-3	-2	-1	U/M	DWG SIZE	PART NO	DESCRIPTION	ITEM NO

QTY	REQD	PER	ASSY	PART NO	DESCRIPTION	ITEM NO	
-1					LEADMAKER		
-2					BENCH MODEL K	MECH POST FEED	
-3					BENCH MODEL G	MECH PRE FEED	
1	1	1	-	B	22594-8	NUT, HEX (1/2-20)	70
1	1	1	-	B	240628-1	PLATE, ADJUSTMENT	69
1	1	1	-	B	240626-1	SHAFT, PIVOT	68
1	1	1	-	B	240633-1	BUSHING	67
1	1	1	-	A	455680-1	LEVER, INTERMEDIATE	66
1	1	1	-	B	240629-1	BLOCK, PIVOT	65
1	1	1	-	A	240632-2	SCREW, ADJ FEED ROD	64
1	1	1	-	B	240659-3	PIN, CAM ROLLER	63
1	1	1	-	B	240658-1	ROLLER, CAM	62
1	1	1	-	B	454398-2	ROD, FEED	61
1	1	1	-	A	454178-1	GUIDE, FEED ROD	60
1	1	1	-	C	454220-1	CAP, RAM	59
1	1	1	-	D	454485-1	HOUSING	58
							57
1	1	1	-	B	3-694433-0	PAWL, FEED	56
1	1	1	-	B	240624-1	PIN, FEED FINGER	55
1	1	1	-	B	691499-1	SPRING, FEED FINGER	54
1	1	1	-	A	690541-1	HOLDER, FEED FINGER	53
1	1	1	-	B	455679-1	LEVER, TERMINAL FEED ARM	52
							51
							50
1	-	-	-	B	690602-6	CAM, PRE-FEED 1 5/8 ST	49
-	1	-	-	B	690602-5	CAM, PRE-FEED 1 1/8 ST	48
-	-	1	-	B	690501-4	CAM, POST-FEED 1 5/8 ST	47
							46
1	1	1	-	A	690191-1	PLUG, NYLON	45
1	1	1	-	C	455673-1	RAM	44
1	1	1	-	A	690125-1	WASHER, LAMINATED	43
1	1	1	-	A	690124-1	WASHER, RAM	42
1	1	1	-	A	7-21002-9	BOLT, CRIMPER (5/16x1.00)	41
1	1	1	-	A	23241-6	BALL, STEEL	40
1	1	1	-	A	690170-1	SPRING, COMPRESSION	39
1	1	1	-	C	690142-1	DISC, INSULATION	38
1	1	1	-	D	354777-1	WIRE DISC, PLASTIC	37
1	1	1	-	A	22480-5	WASHER, SPRING	36
1	1	1	-	B	690212-1	POST, RAM	35
							34
1	1	1	-	D	455675-6	PLATE, BASE	33
							32
							31
1	1	1	-	B	455689-1	BLOCK, STRIP GUIDE ADJ	30
1	1	1	-	C	318042-1	STRIP GUIDE PLATE ASSY	29
1	1	1	-	C	455888-3	SPACER, FRONT SHEAR DEP	28
2	2	2	-	A	1-22284-0	SPRING, DRAG	27
1	1	1	-	B	690546-1	LEVER, DRAG RELEASE	26
1	1	1	-	B	240792-1	DRAG, TERMINAL	25
1	1	1	-	D	6-690440-0	GUIDE, STRIP (REAR)	24
1	1	1	-	A	690438-9	GUIDE, STRIP (FRONT)	23
							22
1	1	1	-	A	4-22284-9	SPRING, FEED RETURN	21
							20
1	1	-	-	B	458230-1	STRIPPER	19
							18
							17
1	1	1	-	B	318563-1	GUARD, CHIP, FRONT	16
							15
1	1	1	-	B	690462-1	HOLDER, SHEAR (REAR)	14
1	1	1	-	C	690463-1	SHEAR, FLOAT (REAR)	13
2	2	2	-	A	5-22280-0	SPRING, SHEAR	12
2	2	2	-	B	690461-1	STOP, SHEAR	11
1	1	1	-	C	690459-1	HOLDER, SHEAR (FRONT)	10
1	1	1	-	C	454276-1	SHEAR, FLOAT (FRONT)	9
1	1	1	-	C	904199-1	ANVIL	8
							7
1	1	1	-	A	690468-1	DEPRESSOR, SHEAR (REAR)	6
1	1	1	-	C	1-455889-4	DEPRESSOR, SHEAR (FRONT)	5
1	1	1	-	B	1-238011-9	SPACER, BLOCK CRIMPER	4
1	1	1	-	C	461296-6	CRIMPER, INSULATION	3
1	1	1	-	C	2-455888-4	SPACER, CRIMPER	2
1	1	1	-	C	467681-4	CRIMPER, WIRE	1
-3	-2	-1	U/M	DWG SIZE	PART NO	DESCRIPTION	ITEM NO

QTY	REQD	PER	ASSY	PART NO	DESCRIPTION	ITEM NO
REVISION OF EACH ASSY NO (WHEN BLANK, USE DWG REVISION)						
DIMENSIONS IN INCHES. DO NOT SCALE PRINT. TOLERANCES UNLESS OTHERWISE SPECIFIED.						
2 PLC DEC ± .02						
3 PLC DEC ± .01						
4 PLC DEC ± .005						
ANGLES ± -						
SURF TEXTURE: ✓						
REMOVE BURRS, BREAK SHARP EDGES R.015 MAX						
MATERIAL LIST						
MATERIAL - HT TR - FIN -						
DR 21MAR97 APP 25MARG7 J.DODDS						
CHK 25MARG7 REL - C.ERISMAN						
NAME SIDE FEED HDM APPLICATOR MACHINE REF MINI APPL						
SCALE - DWG NO 680446 SHEET 1 OF 1 REV A						

THIS DRAWING IS A CONTROLLED DOCUMENT FOR AMP INCORPORATED. IT IS SUBJECT TO CHANGE AND THE CONTROLLING ENGINEERING ORGANIZATION SHOULD BE CONTACTED FOR THE LATEST REVISION.

THIS INFORMATION IS CONFIDENTIAL AND IS DISCLOSED TO YOU ON CONDITION THAT NO FURTHER DISCLOSURE IS MADE BY YOU TO OTHER THAN AMP PERSONNEL WITHOUT WRITTEN AUTHORIZATION FROM AMP INCORPORATED, HARRISBURG, PA.

# Mouser Electronics

Authorized Distributor

Click to View Pricing, Inventory, Delivery & Lifecycle Information:

[TE Connectivity:](#)

[680446-1](#)