

PROB		LOC	Q1ST	REVISIONS				DATE	APPD
5368	DF	FO	P	F	ZONE	LTR	DESCRIPTION		
							D REV PER 0600-7177-98 JY	11-98	DG

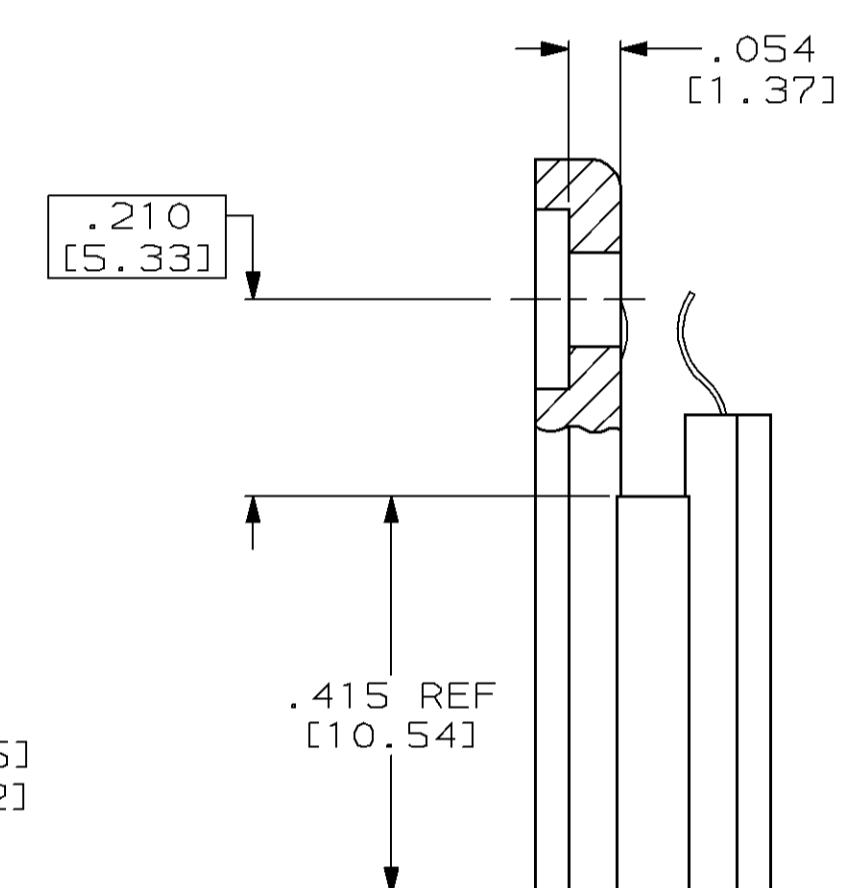

TAB .006 THICK X .030 WIDE
 [0.14] [0.76]

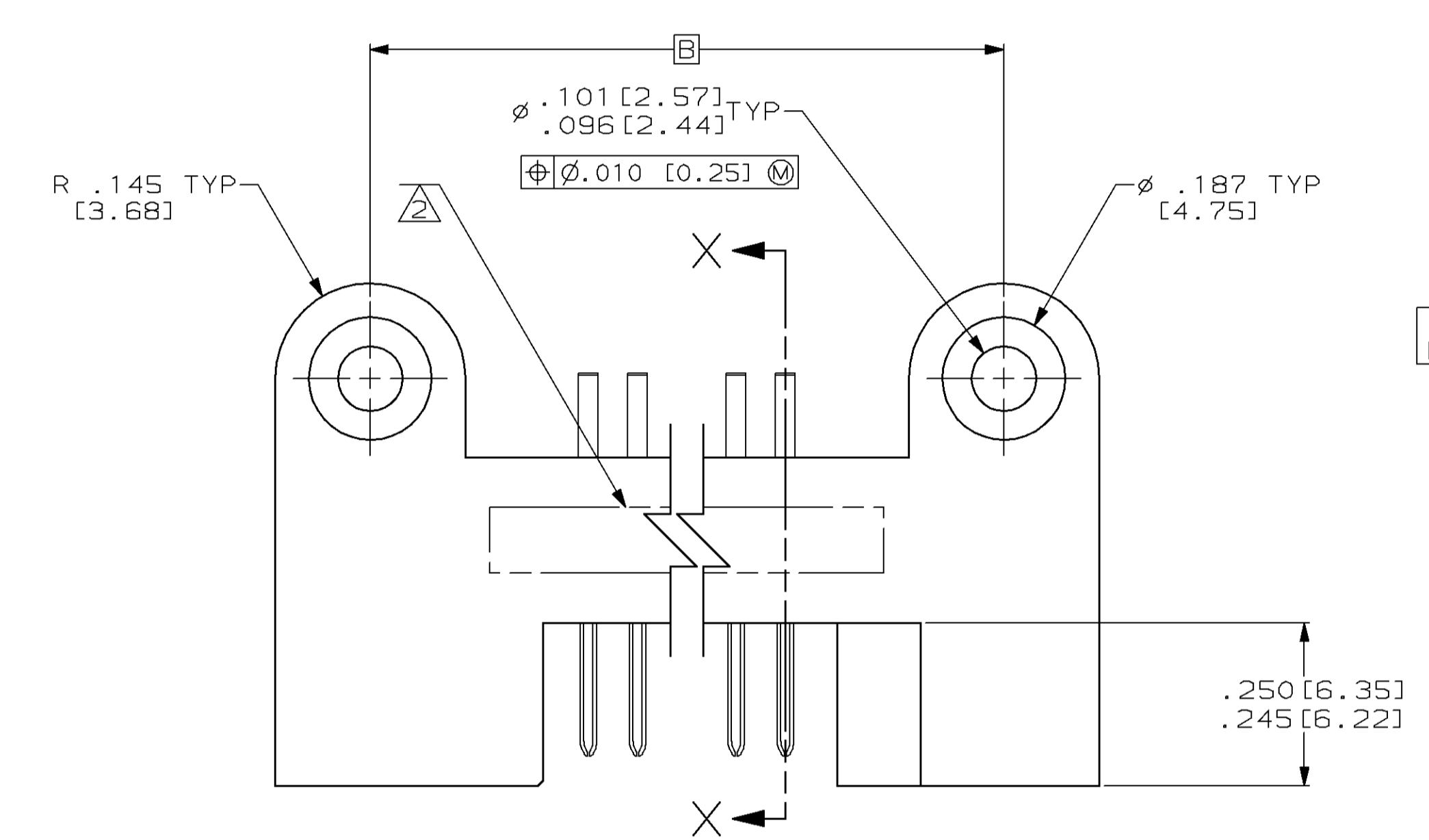
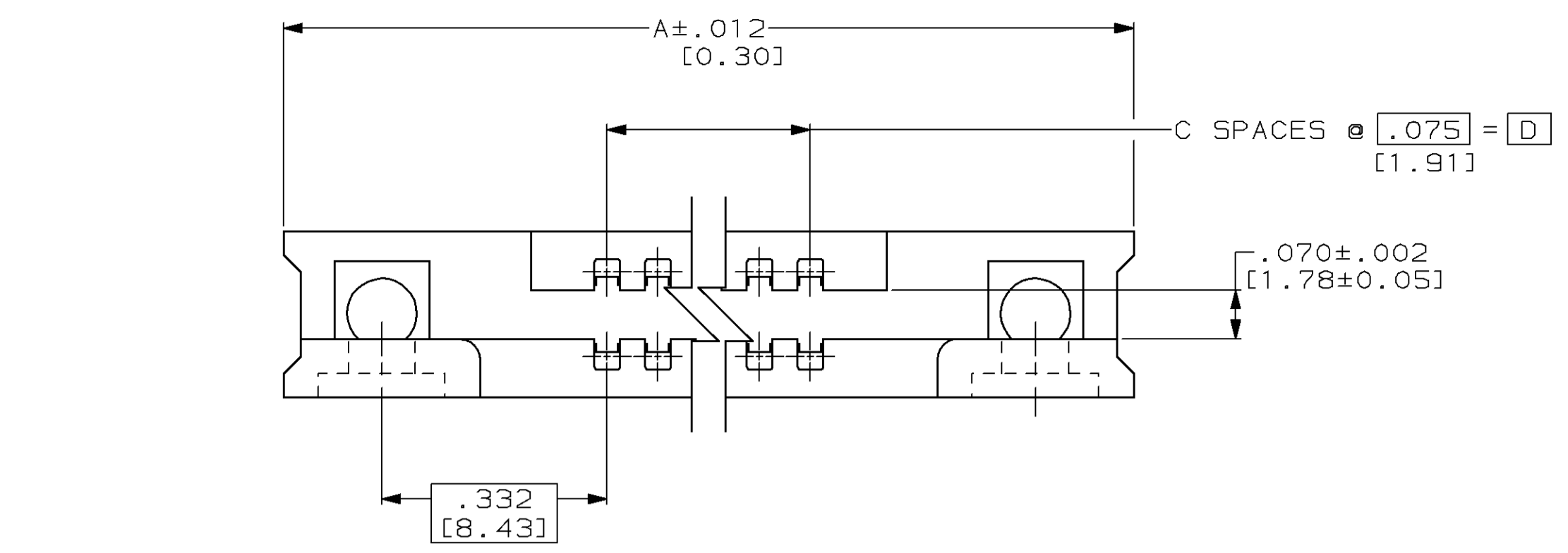
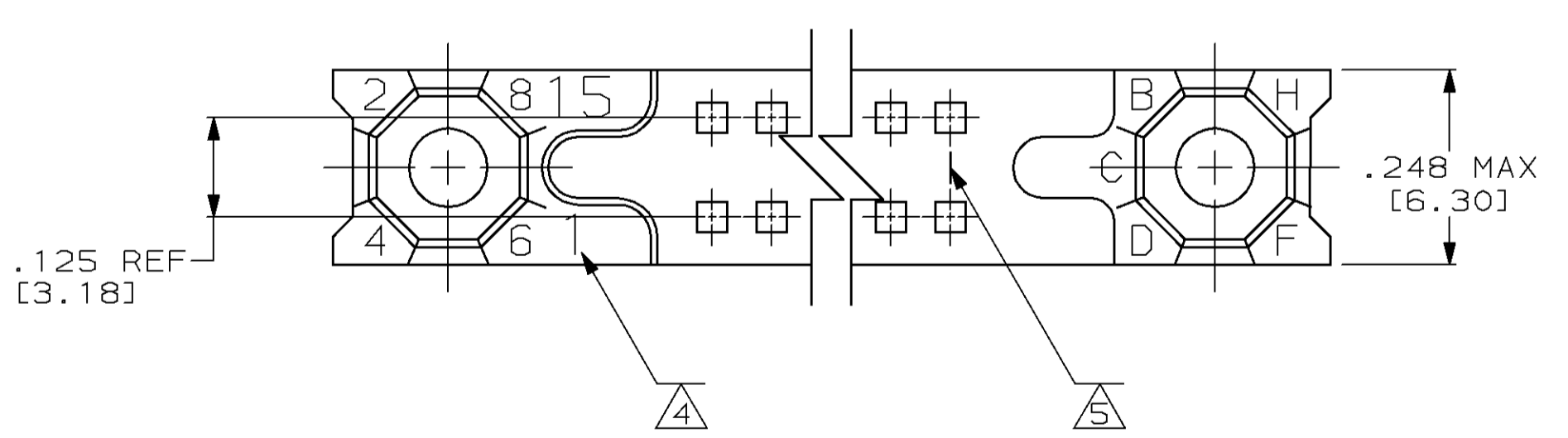
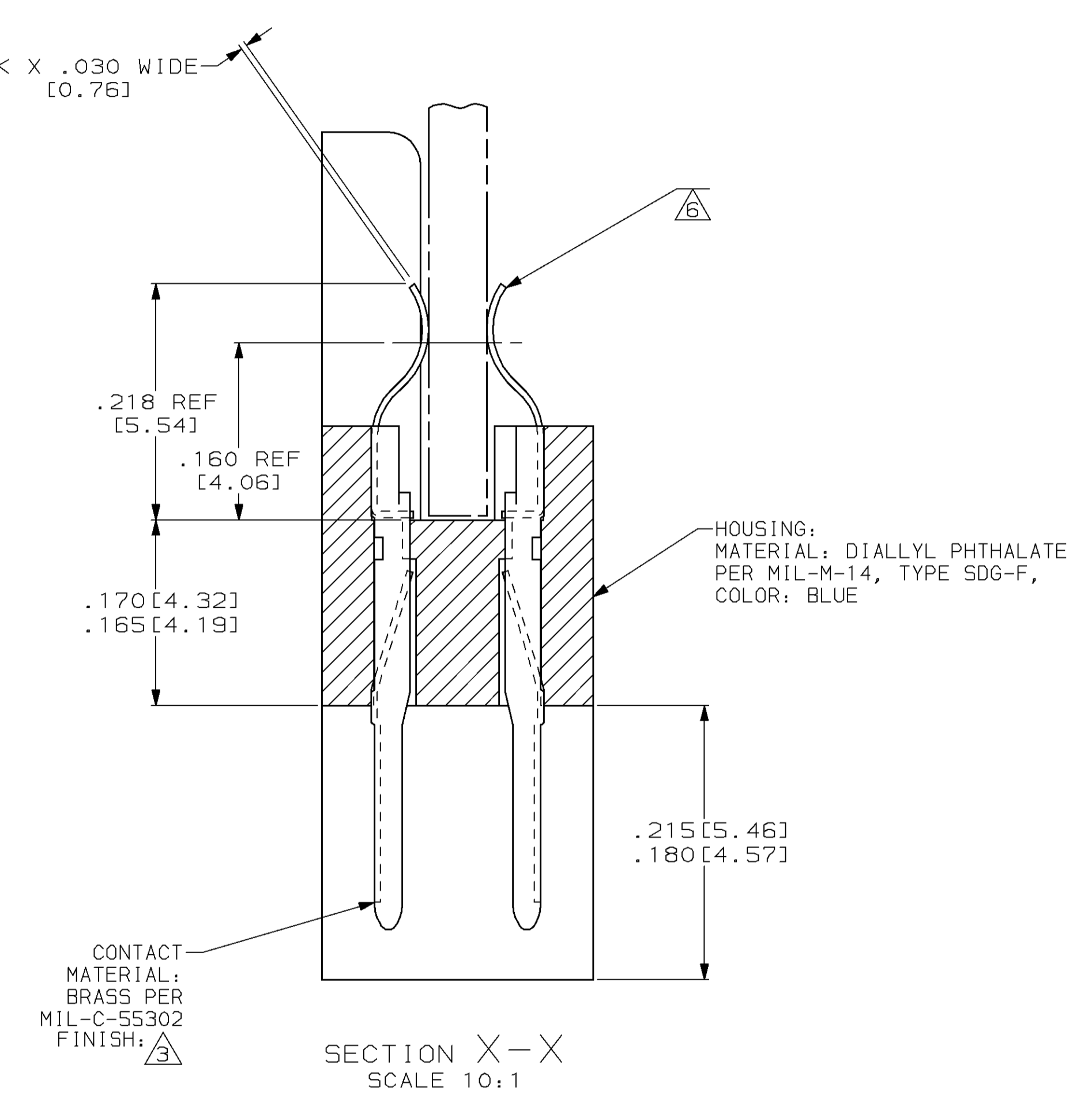

- GROUP A INSPECTION PER PARA 4.6.1 OF MIL-C-55302.
- CUSTOMER PART NUMBER, AMP, DATE CODE AND PART NUMBER MARKED IN THIS AREA.
- FINISH: .000030 GOLD IN CONTACT AREA, .000100 TIN-LEAD ON TAILS, OVER .000050 NICKEL, OVER ENTIRE CONTACT.
- CAVITY IDENTIFICATION NUMBERS MOLDED OR MARKED SEE TABLE.
- LINE INDICATING EVERY FIFTH CAVITY MOLDED OR MARKED.
- TABS PRETINNED BY AMP FOR SOLDERING BY CUSTOMER.

629-062	3	15 - 1	.975 [24.77]	13	1.640 [41.66]	1.930 [49.02]	28	583801-1
CUSTOMER PART NUMBER	CONTACT FINISH REF	CAVITY IDENT	D	C	B	A	NUMBER OF POSITIONS	PART NUMBER
DO NOT SCALE PRINT. UNLESS SPECIFIED DIMENSIONS IN INCHES [mm] TOLERANCES ON +			DR 08-25-97 T. THOMPSON			AMP AMP Incorporated Harrisburg, PA 17105-3608		
2 PLC DEC ± .005 (0.13)			CHK 08-03-97 D. MILLER					
3 PLC DEC ± .005 (0.13)			APPD 08-03-97 D. MILLER			NAME		
ANGLES ±			APPD 08-03-97 T. THOMPSON			PIN HEADER ASSEMBLY, .075¢ BOX		
MATERIAL			PRODUCT SPEC			SIZE		
FINISH			APPLICATION SPEC			CAGE CODE		
SEE TABLE			-			D 00779		
			WEIGHT			DRAWING NO		
						583801		
						SCALE 5:1		
						SHEET 1 OF 1		

Mouser Electronics

Authorized Distributor

Click to View Pricing, Inventory, Delivery & Lifecycle Information:

[TE Connectivity:](#)

[583801-1](#)