

PART NUMBER	REV	FIRST USED	POWER UNIT	FEED TYPE	DESCRIPTION
1852550-1	A	122500-1	LEADMAKER	POST FEED	CUTS CARRIER
1852550-2	A	565435-5	BENCH MODEL K	PRE FEED	CUTS CARRIER
1852550-3	A	354500-1	BENCH MODEL G	PRE FEED	CUTS CARRIER
1852550-6	A	122500-1	LEADMAKER	POST FEED	CONTINUOUS CARRIER
7-1852550-7	A	-	-	-	SPARE PARTS



TERMINAL NAME: TERMINAL-MINI-BLADE RCPT(FEMALE)				
SOCKET	PIN	TE TERMINAL - TE CRIMP SPECS		
1438232-3	-	PAD LTR	CRIMP HEIGHT	WIRE SIZE
-	-	A	1.57±0.05mm(.062±.002)	16AWG
-	-	B	-	-
-	-	C	-	-
-	-	D	-	-
SEAL PN.	CRIMP	SIZE	TYPE	RANGE
-	WIRE	2.39mm(.094)	F	16 AWG
-	INSUL	3.48mm(.137)	F	-
WIRE STRIP LENGTH	TERM APPL SPEC	FEED	APPLICATOR INSTRUCTIONS	SET UP GAGE
.187 - .202	NONE	.622	408-8040	458637-1

LOC	DIST	P	LTR	DESCRIPTION	DATE	BY	APPD
A	66			RELEASED	05SEP2007	C.C	S.Y

- △ RECOMMENDED SPARE PARTS
- △ GREASE LIGHTLY
- △ GUARD MUST BE IN PLACE WHEN OPERATING APPLICATOR IN A BENCH MACHINE

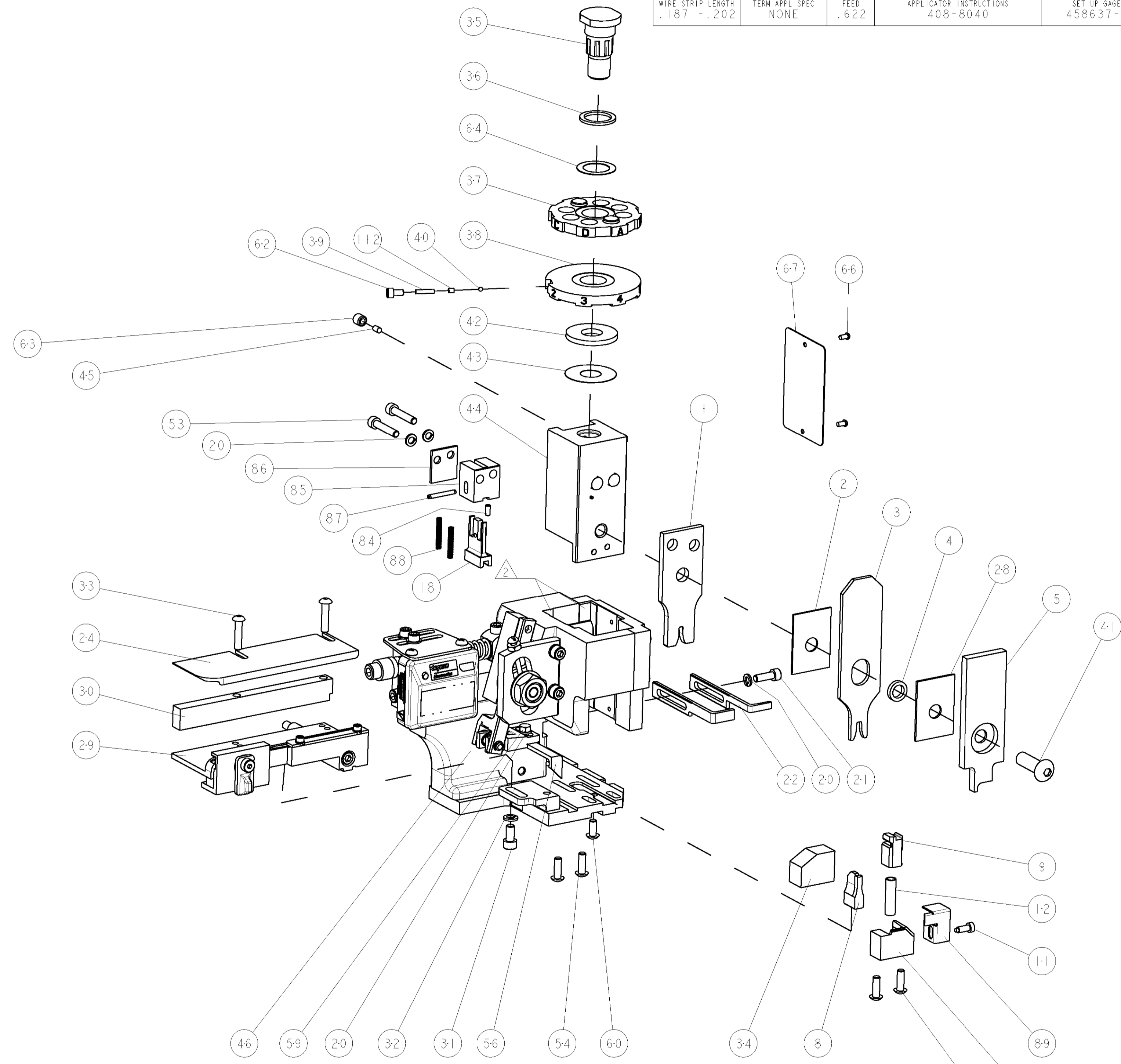
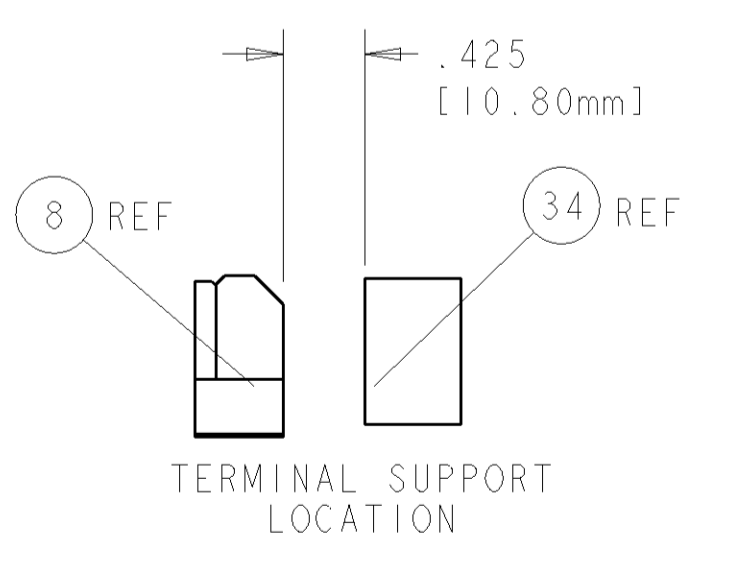
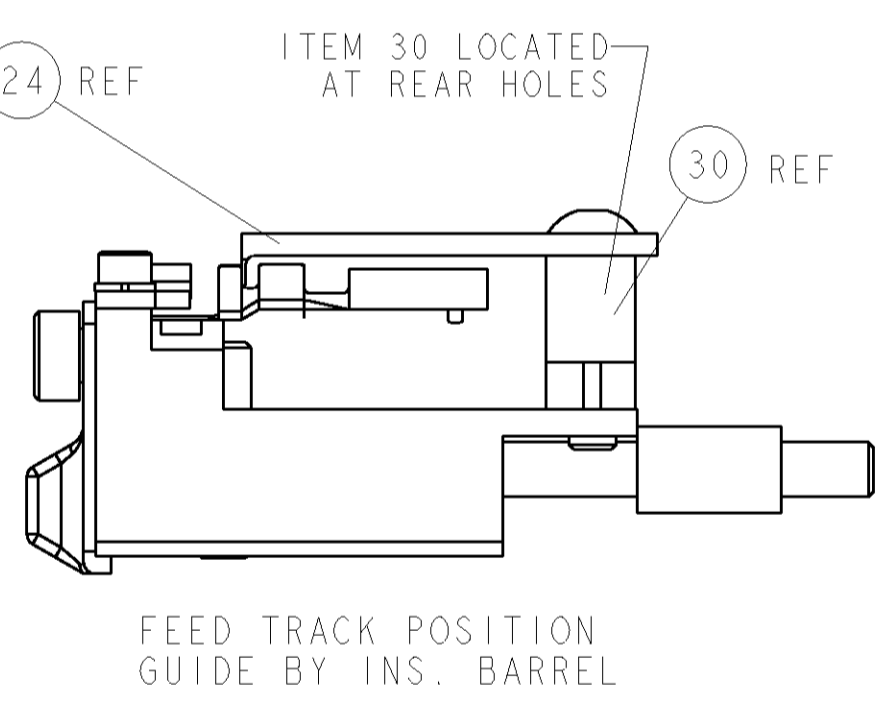
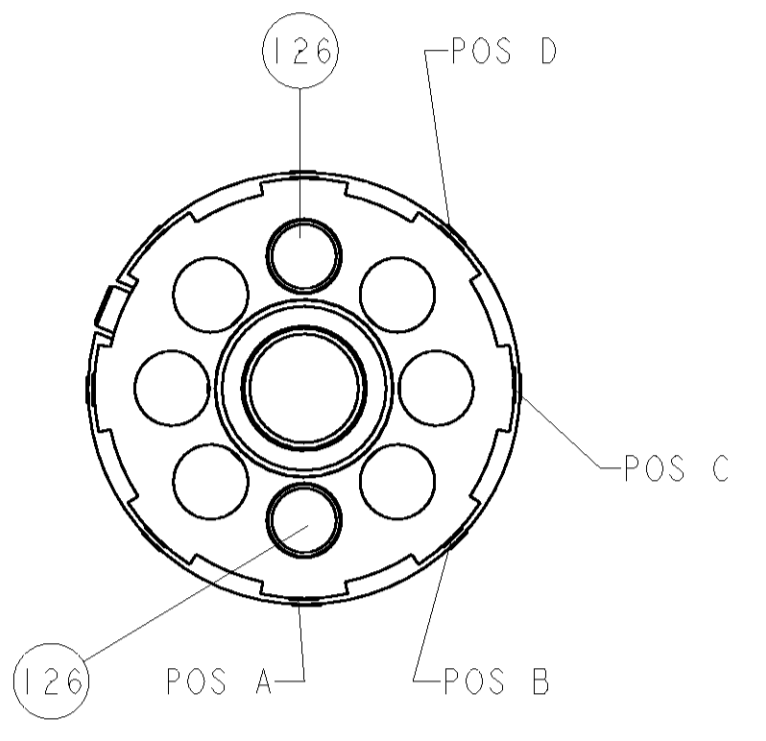

-	2	2	2	2	-	1-354779-0	PIN, WIRE DISC, .3040	126
△	-	-	REF	-	..	455749-1	GUARD WINDOW	116
△	-	-	REF	-	..	679532-1	INSERT, GUARD	115
-	1	1	1	1	-	690603-1	SPRING ASSIST AMP-O-MATOR APPLICATOR	112
-	1	1	1	1	-	1-21002-7	SCR, BTN SKT HD CAP 6-32 X .375	91
-	1	1	1	1	-	318563-1	GUARD, FRONT CHIP	89
-	2	2	2	2	-	1-22278-9	SPRING, COMPRESSION	88
-	1	1	1	1	-	4-21028-0	PIN, SLOTTED SPRING .094 X .750	87
-	1	1	1	1	-	455053-1	PLATE, RETAINING	86
-	1	1	1	1	-	455052-1	CARRIER, HOLD DOWN	85
-	1	1	1	1	-	2-21008-1	SCR, SET, SELF LOCKING 1/4-20 X .250	84
-	1	1	1	1	-	4088040	SF APPL INST 408-8040	72
-	1	1	1	1	-	217238-1	GENERAL INSTRUCTION PKG	71
-	1	1	1	1	-	461264-1	PLATE, IDENTIFICATION	67
-	2	2	2	2	-	21017-2	SCREW, DRIVE	66
-	1	1	1	1	-	986950-1	WASHER, FLAT PRECISION	64
-	1	1	1	1	-	21009-2	SCR, SET, SELF LOCKING 1/4-20 X .250	63
-	1	1	1	1	-	23030-1	SCR, SKT HD CAP 6-32 x .25	62
-	1	1	1	1	-	22733-8	SCR, BHSC, SELF-LOCKING, 8-32 X .375	60
-	1	1	1	1	-	2-22603-0	SCR, HEX HD CAP 8-32 X .312	59
-	1	1	1	1	-	458537-2	PAWL, FEED	56
-	4	4	4	4	-	2-21002-2	SCR, BTN SKT HD CAP 8-32 X .500	54
-	2	2	2	2	-	3-21000-0	SCR, SKT HD CAP 8-32 X .875	53
-	-	-	-	-	..	690602-6	CAM, PRE FEED, 1 5/8	49
-	-	-	-	-	..	690602-5	CAM, PRE FEED, 1 1/8	48
-	1	-	-	-	-	690501-4	CAM, POST FEED, 1 5/8	47
-	1	1	1	1	-	459456-1	APPL. BASIC SUB ASSY (SIDE WISE MOCA)	46
-	1	1	1	1	-	690191-1	PLUG, NYLON	45
-	1	1	1	1	-	1-455673-3	RAM, SIDE FEED	44
-	1	1	1	1	-	690125-1	SHIM SUB-ASSY	43
-	1	1	1	1	-	690124-1	WASHER, RAM (.115)	42
-	1	1	1	1	-	7-21002-9	SCR, BTN SKT HD CAP 5/16-24 X 1.00	41
-	1	1	1	1	-	23241-6	BALL, STEEL	40
-	1	1	1	1	-	690170-1	SPRING, COMPRESSION	39
-	1	1	1	1	-	690142-4	DISC, INSULATION	38
-	1	1	1	1	-	354777-1	WIRE DISC, ASSEMBLY	37
-	1	1	1	1	-	22480-5	SPRING, COMPRESSION	36
-	1	1	1	1	-	690212-1	POST, RAM	35
-	1	1	1	1	-	690786-3	TERMINAL SUPPORT	34
-	2	2	2	2	-	2-21002-4	SCR, BTN SKT HD CAP 8-32 X .750	33
-	1	1	1	1	-	21024-5	WASHER, SPRG LOCK, REG NO 10	32
-	1	1	1	1	-	3-21000-4	SCR, SKT HD CAP 10-32 X .375	31
-	1	1	1	1	-	1320908-2	SPACER, STRIP GUIDE	30
-	1	1	1	1	-	1633091-1	ASSEMBLY, STRIP GUIDE	29
-	1	1	1	1	-	1-455888-0	SPACER, CRIMPER	28
-	1	1	1	1	-	1320928-5	PLATE, STRIP GUIDE	24
-	1	-	-	-	-	690472-2	STRIPPER	22
-	1	1	1	1	-	2-21000-7	SCR, SKT HD CAP 8-32 X .500	21
-	4	4	4	4	-	21024-4	WASHER, SPRG LOCK, REG NO 8	20
-	-	-	-	-	-	690472-1	STRIPPER	19
△	1	1	1	1	-	8-1338389-7	HOLD DOWN, TERMINAL	18
△	1	1	1	1	-	679625-1	SHEAR HOLDER, FRONT (NO CUT)	13
△	1	1	1	1	-	3-22280-3	SPRING, COMPRESSION	12
△	1	1	1	1	-	690461-1	STOP, SHEAR	11
△	1	1	1	1	-	690459-1	SHEAR HOLDER, FRONT	10
△	1	1	1	1	-	454276-1	FLOATING SHEAR, FRONT	9
△	1	1	1	1	-	4-1633535-1	ANVIL, COMBINATION	8
-	-	-	-	-	..	-	-	7
-	-	-	-	-	..	-	-	6
-	1	1	1	1	-	1-455889-4	DEPRESSOR, SHEAR	5
-	1	1	1	1	-	238011-4	BLOCK, CRIMPER SPACER	4
△	1	1	1	1	-	6-1633471-1	CRIMPER, INSULATION F	3
△	1	1	1	1	-	455888-8	SPACER, CRIMPER	2
△	1	1	1	1	-	1-568176-1	CRIMPER, WIRE	1

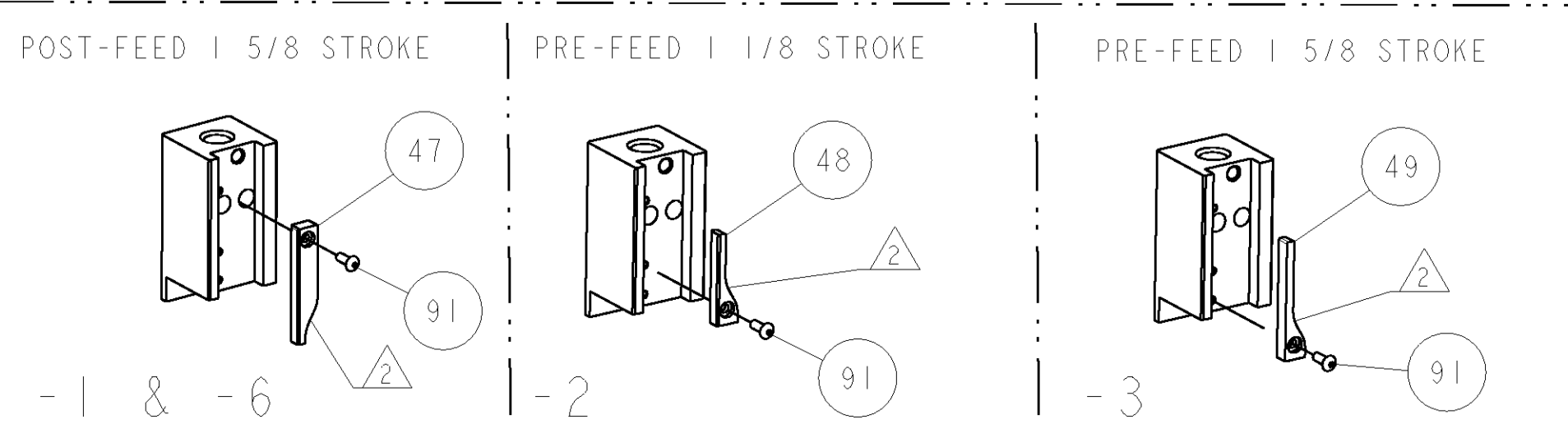

DIMENSIONS:	TOLERANCES UNLESS OTHERWISE SPECIFIED:	APPROVED:	DATE:	DESCRIPTION:	ITEM NO:
INCHES	0 PLC ±.01 1 PLC ±.01 2 PLC ±.01 3 PLC ±.01 4 PLC ±.01	APPROVED	05SEP2007	SIDE FEED HDM APPLICATOR	
MATERIAL:	FINISH:	WEIGHT:	SCALE:	3:5	SHEET 1 OF 1
CUSTOMER DRAWING		SCALE: 3:5		REV A	

CUSTOMER VIEWABLE ASSEMBLY

Mouser Electronics

Authorized Distributor

Click to View Pricing, Inventory, Delivery & Lifecycle Information:

[TE Connectivity:](#)

[1852550-2](#)