

PART NUMBER	REV	FIRST USED	POWER UNIT	FEED TYPE	DESCRIPTION
1852473-1	A	122500-1	LEADMAKER	POST FEED	CUTS CARRIER
1852473-2	A	565435-5	BENCH MODEL K	PRE FEED	CUTS CARRIER
1852473-3	A	354500-1	BENCH MODEL G	PRE FEED	CUTS CARRIER
1852473-6	A	122500-1	LEADMAKER	POST FEED	CONTINUOUS CARRIER
7-1852473-7	A	-	-	-	SPARE PARTS

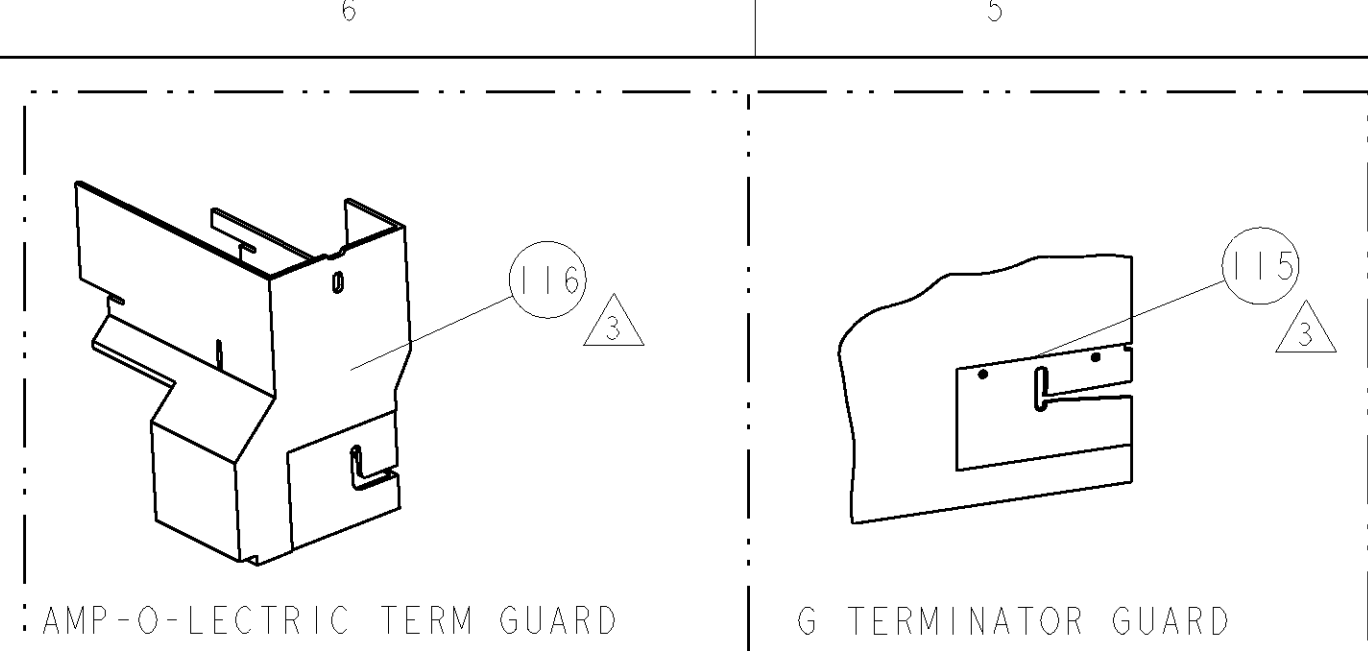

TYCO PN		MANUF PN		MOLEX TERMINAL - MOLEX CRIMP SPECS	
1949354-1	33012-3001				
1949354-2	33001-3003	PAD LTR		CRIMP HEIGHT	WIRE SIZE
1949354-3	33012-3021	A		.065±.002 [1.65±0.05mm]	14AWG
1949354-4	33001-3021	B		.055±.002 [1.40±0.05mm]	1.5mm2
-	-	C		.053±.002 [1.35±0.05mm]	16AWG
-	-	D		-	-
-	-	CRIMP		SIZE	TYPE
-	-	WIRE		.094 [2.39mm]	F
-	-	INSUL		.098 [2.49mm]	OV
WIRE STRIP LENGTH	TERM APPL SPEC	FEED	APPLICATOR INSTRUCTIONS	SET UP GAGE	
.179 - .194	NONE	.420	408-8040	458637-1	

LOC	DIST	P	LTR	DESCRIPTION	DATE	BY	APPD
A	66			RELEASED	01JUN2007	MEH	GB

- △ RECOMMENDED SPARE PARTS
- △ GREASE LIGHTLY
- △ GUARD MUST BE IN PLACE WHEN OPERATING APPLICATOR IN A BENCH MACHINE

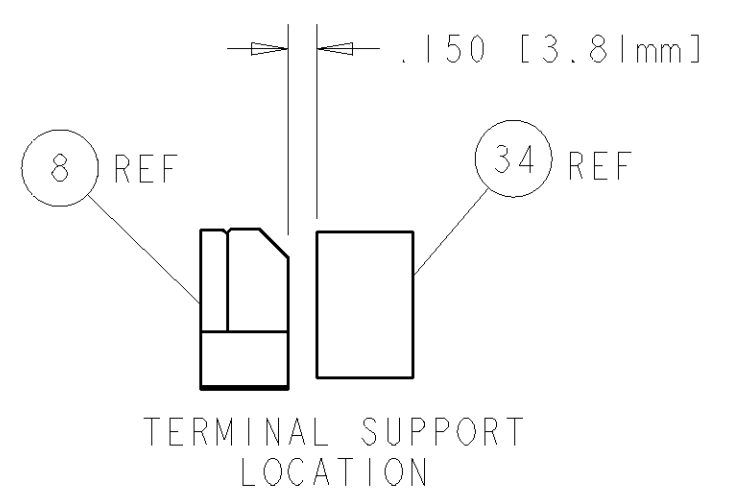
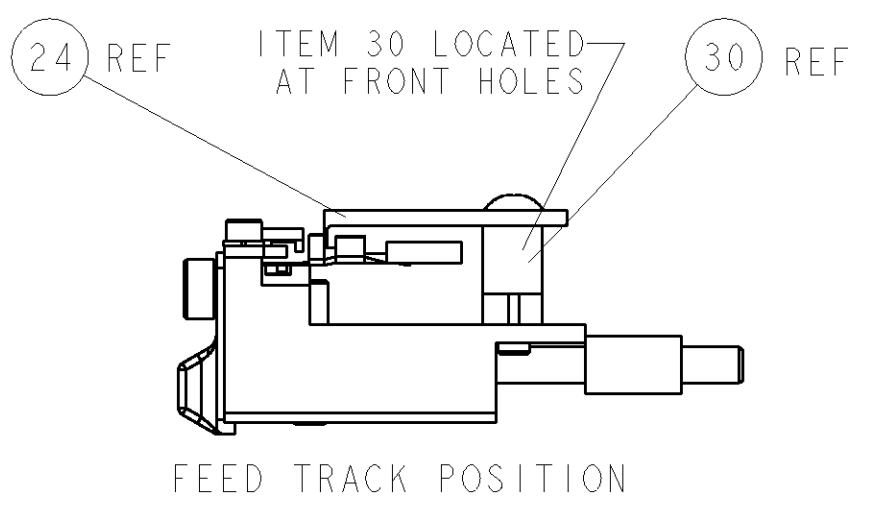
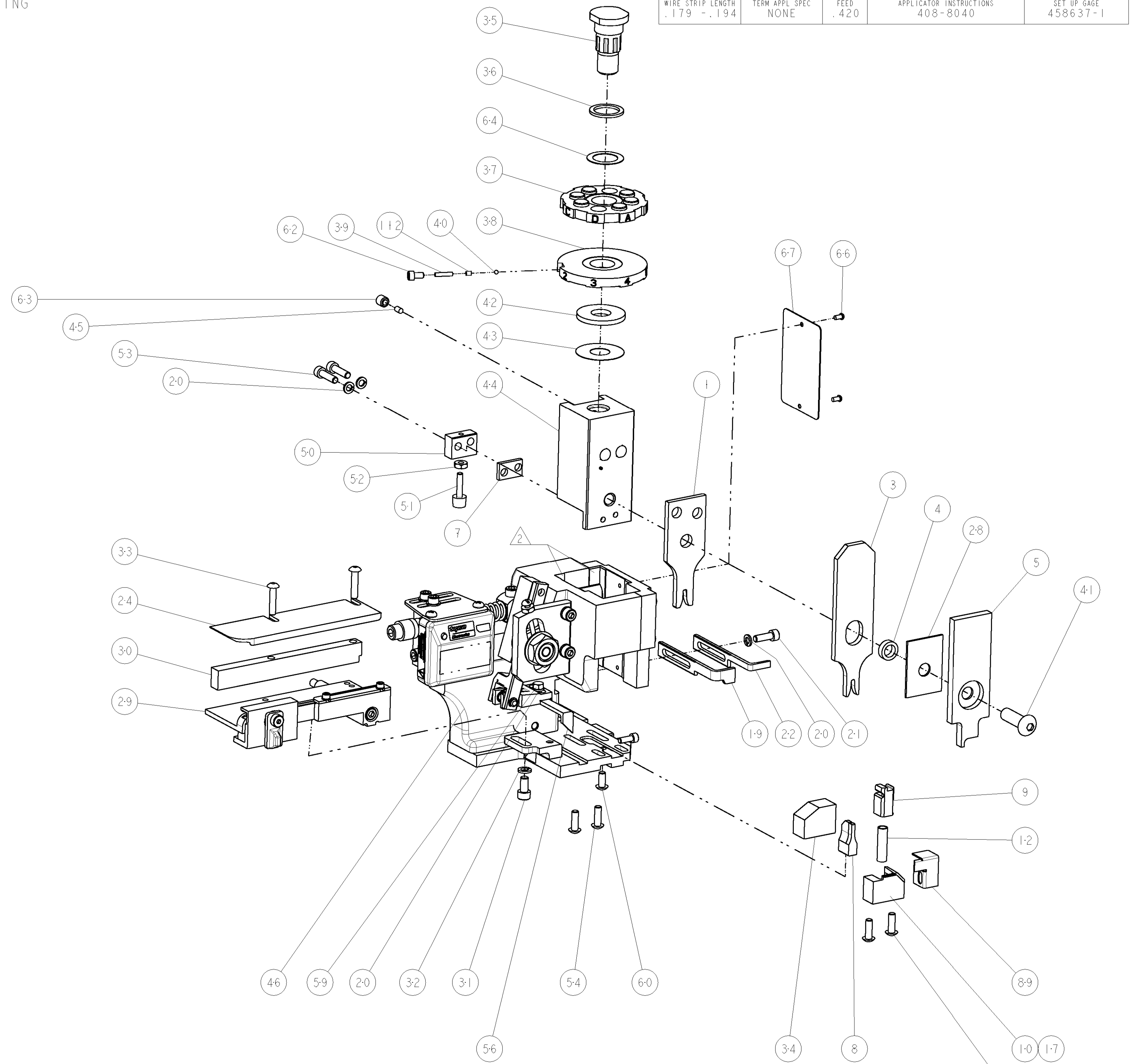
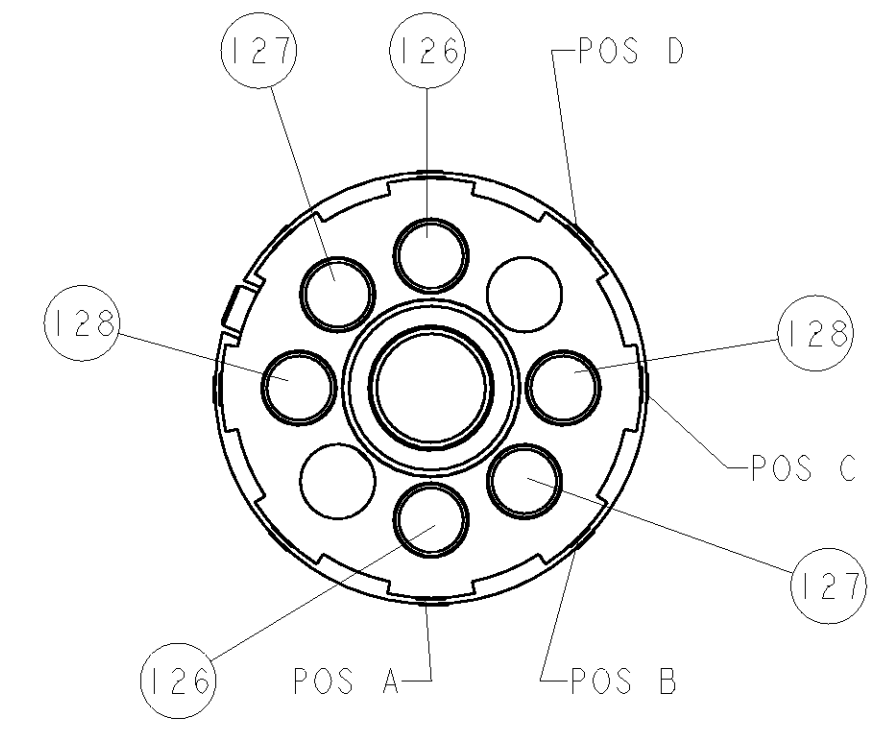

-	2	2	2	2	-	3-354779-6	PIN, WIRE DISC, .3170	128
-	2	2	2	2	-	3-354779-0	PIN, WIRE DISC, .3140	127
-	2	2	2	2	-	1-354779-0	PIN, WIRE DISC, .3040	126
-	-	-	REF	-	..	455749-1	GUARD WINDOW	116
-	-	REF	-	-	..	679532-1	INSERT, GUARD	115
-	1	1	1	1	-	690603-1	SPRING ASSIST AMP-O-MATOR APPLICATOR	112
-	1	1	1	1	-	1-21002-7	SCR, BTN SKT HD CAP 6-32 X .375	91
-	1	1	1	1	-	318563-1	GUARD, FRONT CHIP	89
-	1	1	1	1	-	4088040	SF APPL INST 408-8040	72
-	1	1	1	1	-	217238-1	GENERAL INSTRUCTION PKG	71
-	1	1	1	1	-	461264-1	PLATE, IDENTIFICATION	67
-	2	2	2	2	-	21017-2	SCREW, DRIVE	66
-	1	1	1	1	-	986950-1	WASHER, FLAT PRECISION	64
-	1	1	1	1	-	21009-2	SCR, SET, SELF LOCKING 1/4-20 X .250	63
-	1	1	1	1	-	23030-1	SCR, SKT HD CAP 6-32 X .25	62
-	1	1	1	1	-	22733-8	SCR, BHSC, SELF-LOCKING, 8-32 X .375	60
-	1	1	1	1	-	2-22603-0	SCR, HEX HD CAP 8-32 X .312	59
-	1	1	1	1	-	458537-2	PAWL, FEED	56
-	4	4	4	4	-	2-21002-2	SCR, BTN SKT HD CAP 8-32 X .500	54
-	2	2	2	2	-	2-21000-8	SCR, SKT HD CAP 8-32 X .625	53
-	1	1	1	1	-	21018-5	NUT, HEX, REG 6-32	52
-	1	1	1	1	-	811242-2	BUMPER, HOLD DOWN	51
-	1	1	1	1	-	690753-1	SPACER, TONKER	50
-	-	-	-	-	..	690602-6	CAM, PRE FEED, 1 5/8	49
-	-	-	-	-	..	690602-5	CAM, PRE FEED, 1 1/8	48
-	1	-	-	-	-	690501-4	CAM, POST FEED, 1 5/8	47
-	1	1	1	1	-	459456-1	APPL. BASIC SUB ASSY (SIDE WISE MOCA)	46
-	1	1	1	1	-	690191-1	PLUG, NYLON	45
-	1	1	1	1	-	455673-1	RAM, SIDE FEED	44
-	1	1	1	1	-	690125-1	SHIM SUB-ASSY	43
-	1	1	1	1	-	690124-1	WASHER, RAM (.115)	42
-	1	1	1	1	-	7-21002-9	SCR, BTN SKT HD CAP 5/16-24 X 1.00	41
-	1	1	1	1	-	23241-6	BALL, STEEL	40
-	1	1	1	1	-	690170-1	SPRING, COMPRESSION	39
-	1	1	1	1	-	1-690142-3	DISC, INSULATION	38
-	1	1	1	1	-	354777-1	WIRE DISC, ASSEMBLY	37
-	1	1	1	1	-	22480-5	SPRING, COMPRESSION	36
-	1	1	1	1	-	690212-1	POST, RAM	35
-	1	1	1	1	-	690786-3	TERMINAL SUPPORT	34
-	2	2	2	2	-	2-21002-4	SCR, BTN SKT HD CAP 8-32 X .750	33
-	1	1	1	1	-	21024-5	WASHER, SPRG LOCK, REG NO 10	32
-	1	1	1	1	-	3-21000-4	SCR, SKT HD CAP 10-32 X .375	31
-	1	1	1	1	-	1320908-8	SPACER, STRIP GUIDE	30
-	1	1	1	1	-	1-1633091-4	ASSEMBLY, STRIP GUIDE	29
-	1	1	1	1	-	1-455888-0	SPACER, CRIMPER	28
-	1	1	1	1	-	1320928-1	PLATE, STRIP GUIDE	24
-	1	-	-	-	-	690472-2	STRIPPER	22
-	1	1	1	1	-	2-21000-7	SCR, SKT HD CAP 8-32 X .500	21
-	4	4	4	4	-	21024-4	WASHER, SPRG LOCK, REG NO 8	20
-	-	-	-	-	-	691353-1	STRIPPER	19
-	1	-	-	-	-	679625-1	SHEAR HOLDER, FRONT (NO CUT)	17
-	1	1	1	1	-	3-22280-3	SPRING, COMPRESSION	12
-	1	1	1	1	-	1-21000-9	SCR, SKT HD CAP 6-32 X .375	11
-	-	-	-	-	-	690459-1	SHEAR HOLDER, FRONT	10
-	1	1	1	1	-	454276-1	FLOATING SHEAR, FRONT	9
1	1	1	1	1	-	1-1633535-7	ANVIL, COMBINATION	8
-	1	1	1	1	-	8-240641-6	SPACER	7
-	1	1	1	1	-	2-455889-0	DEPRESSOR, SHEAR	5
-	1	1	1	1	-	4-238011-5	BLOCK, CRIMPER SPACER	4
1	1	1	1	1	-	9-854830-9	CRIMPER, INSULATION SPECIAL	3
1	1	1	1	1	-	4-1490019-1	CRIMPER, WIRE PREMIUM	1

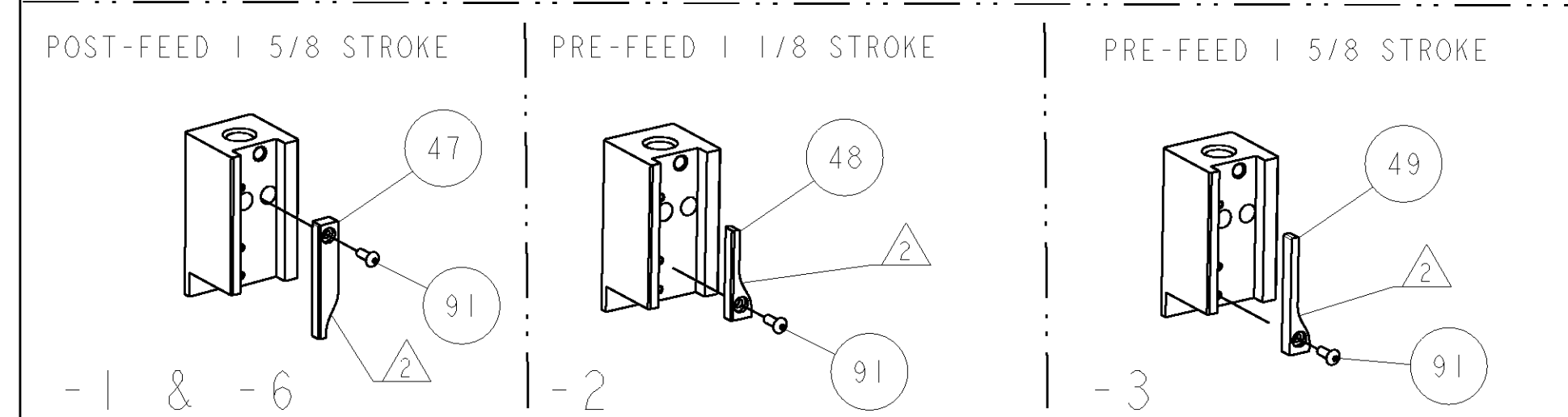

DIMENSIONS:		TOLERANCES UNLESS OTHERWISE SPECIFIED:		MATERIAL:		FINISH:		WEIGHT:		CUSTOMER DRAWING:	
INCHES		0 PLC	±								
		1 PLC	±0.1								
		2 PLC	±0.01								
		3 PLC	±0.001								
		4 PLC	±0.0001								
		ANGLES	±0.001								

CUSTOMER VIEWABLE ASSEMBLY

Mouser Electronics

Authorized Distributor

Click to View Pricing, Inventory, Delivery & Lifecycle Information:

[TE Connectivity:](#)

[1852473-3](#)