

PART NUMBER	REV	FIRST USED	POWER UNIT	FEED TYPE	DESCRIPTION
1852430-1	A	122500-1	LEADMAKER	POST FEED	CUTS CARRIER
1852430-2	A	565435-5	BENCH MODEL K	PRE FEED	CUTS CARRIER
1852430-3	A	354500-1	BENCH MODEL G	PRE FEED	CUTS CARRIER
1852430-6	A	122500-1	LEADMAKER	POST FEED	CONTINUOUS CARRIER
7-1852430-7	A	-	-	-	SPARE PARTS



TERMINAL NAME: TERMINAL		TYCO PN		G&H PN		GROTE & HARTMANN TERMINAL - AMP CRIMP SPECS	
1949275	26121.201.179						
		PAD LTR		CRIMP HEIGHT		WIRE SIZE	
		A		.040±.002[1.02±0.05mm]		22AWG	
		B		.037±.002[.94±0.05mm]		0.25mm2	
		C					
		D					
		CRIMP		SIZE	TYPE	RANGE	
		WIRE		.062 [1.57mm]	F	22 AWG & 0.25mm2	
		INSUL		.080 [2.03mm]	O	∅.058 MAX	
WIRE STRIP LENGTH	TERM APPL SPEC	FEED		APPLICATOR INSTRUCTIONS		SET UP GAGE	
.153 - .168	NONE	.433		408-8040		458637-1	

LOC	DIST	REV	DESCRIPTION	DATE	BY	APPD
A	66		RELEASED	07MAR2007	LG	GB

- △ RECOMMENDED SPARE PARTS
- △ GREASE LIGHTLY
- △ GUARD MUST BE IN PLACE WHEN OPERATING APPLICATOR IN A BENCH MACHINE

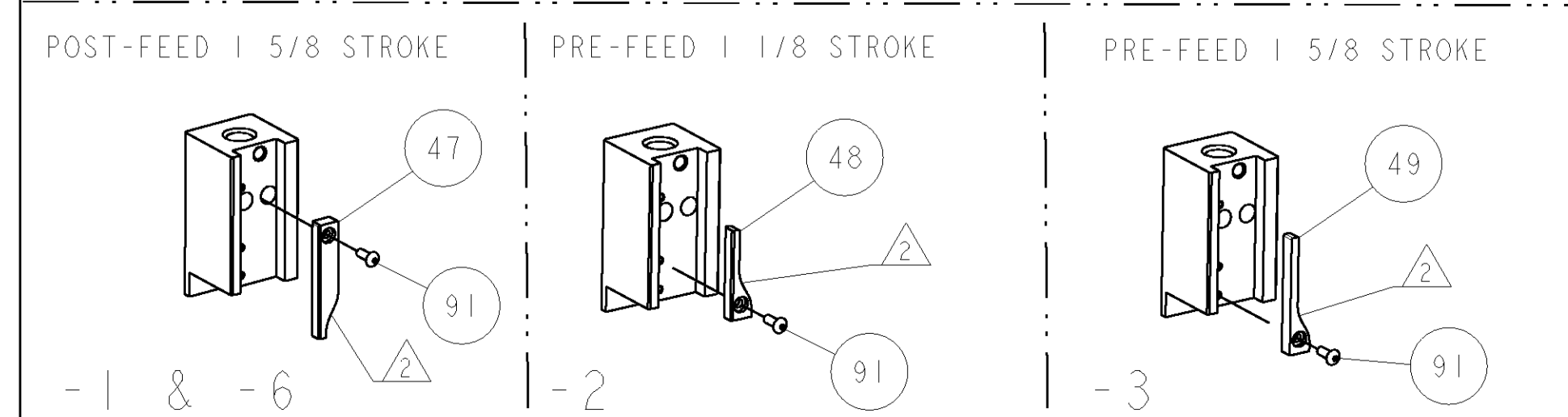
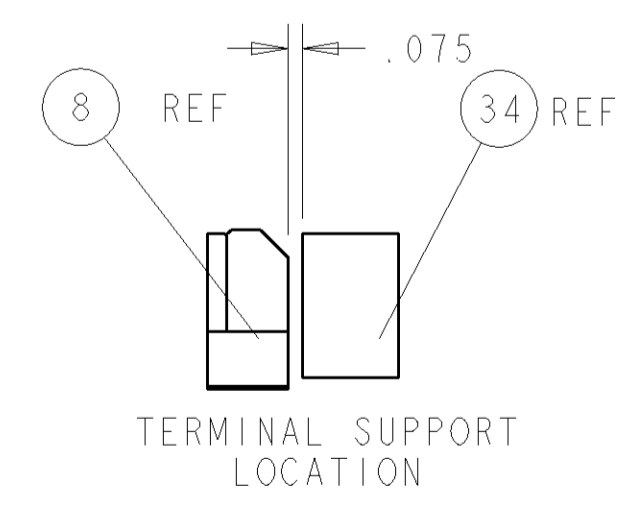
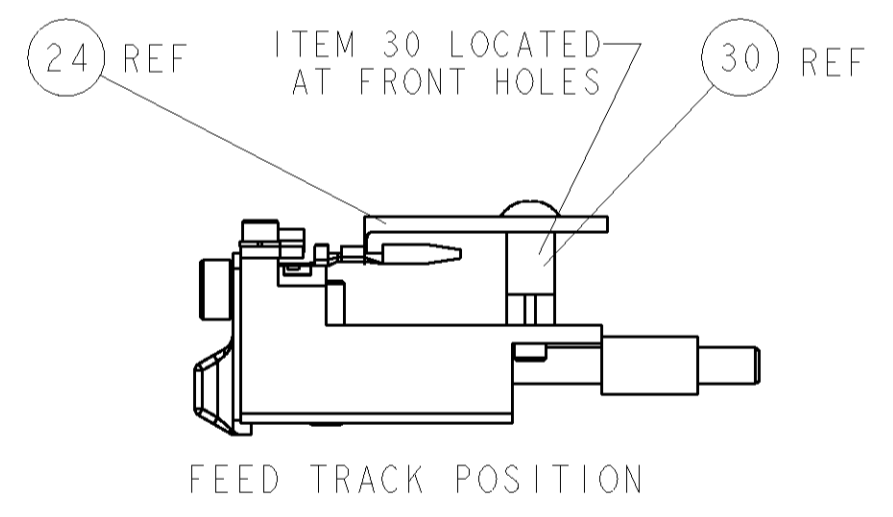
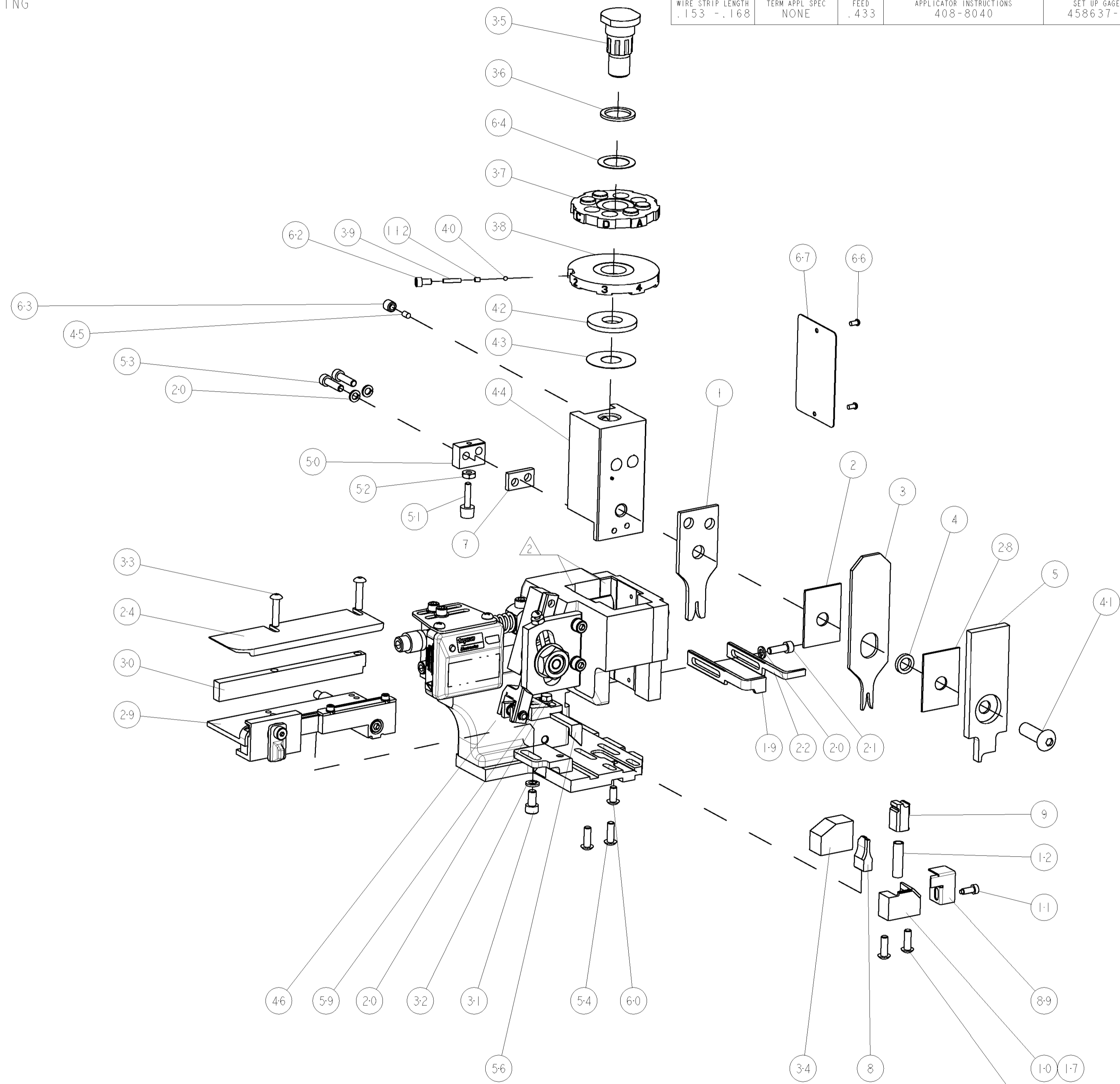
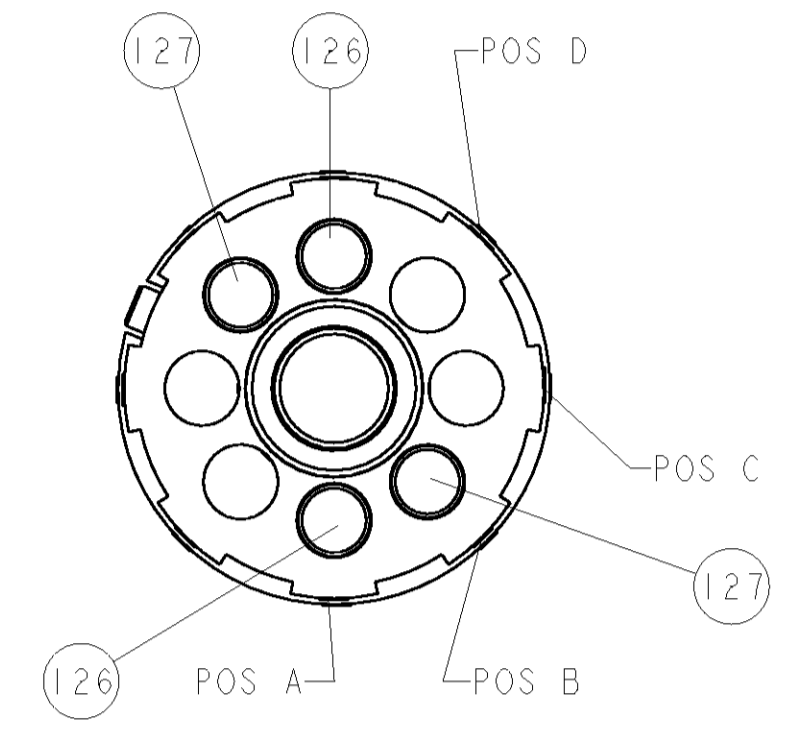

-	2	2	2	2	-	4-354779-2	PIN, WIRE DISC, .3200	127
-	2	2	2	2	-	3-354779-6	PIN, WIRE DISC, .3170	126
△	-	-	REF	-	..	455749-1	GUARD WINDOW	116
△	-	REF	-	-	..	679532-1	INSERT, GUARD	115
-	1	1	1	1	-	690603-1	SPRING ASSIST AMP-O-MATOR APPLICATOR	112
-	1	1	1	1	-	1-21002-7	SCR, BTN SKT HD CAP 6-32 X .375	91
-	1	1	1	1	-	318563-1	GUARD, FRONT CHIP	89
-	1	1	1	1	-	4088040	SF APPL INST 408-8040	72
-	1	1	1	1	-	217238-1	GENERAL INSTRUCTION PKG	71
-	1	1	1	1	-	461264-1	PLATE, IDENTIFICATION	67
-	2	2	2	2	-	21017-2	SCREW, DRIVE	66
-	1	1	1	1	-	986950-1	WASHER, FLAT PRECISION	64
-	1	1	1	1	-	21009-2	SCR, SET, SELF LOCKING 1/4-20 X .250	63
-	1	1	1	1	-	23030-1	SCR, SKT HD CAP 6-32 X .25	62
-	1	1	1	1	-	22733-8	SCR, BHSC, SELF-LOCKING, 8-32 X .375	60
-	1	1	1	1	-	2-22603-0	SCR, HEX HD CAP 8-32 X .312	59
-	1	1	1	1	-	458537-2	PAWL, FEED	56
-	4	4	4	4	-	2-21002-2	SCR, BTN SKT HD CAP 8-32 X .500	54
-	2	2	2	2	-	2-21000-8	SCR, SKT HD CAP 8-32 X .625	53
-	1	1	1	1	-	21018-5	NUT, HEX, REG 6-32	52
-	1	1	1	1	-	811242-2	BUMPER, HOLD DOWN	51
-	1	1	1	1	-	690753-1	SPACER, TONKER	50
-	-	1	-	-	..	690602-6	CAM, PRE FEED, 1/8	49
-	-	1	-	-	..	690602-5	CAM, PRE FEED, 1/16	48
-	1	1	1	1	-	690501-4	CAM, POST FEED, 1/8	47
-	1	1	1	1	-	459456-1	APPL. BASIC SUB ASSY (SIDE WISE MQCA)	46
-	1	1	1	1	-	690191-1	PLUG, NYLON	45
-	1	1	1	1	-	455673-1	RAM, SIDE FEED	44
-	1	1	1	1	-	690125-1	SHIM SUB-ASSY	43
-	1	1	1	1	-	1-690124-4	WASHER, RAM (.120)	42
-	1	1	1	1	-	7-21002-9	SCR, BTN SKT HD CAP 5/16-24 X 1.00	41
-	1	1	1	1	-	23241-6	BALL, STEEL	40
-	1	1	1	1	-	690170-1	SPRING, COMPRESSION	39
-	1	1	1	1	-	690142-5	DISC, INSULATION	38
-	1	1	1	1	-	354777-1	WIRE DISC, ASSEMBLY	37
-	1	1	1	1	-	22480-5	SPRING, COMPRESSION	36
-	1	1	1	1	-	690212-1	POST, RAM	35
-	1	1	1	1	-	690786-6	TERMINAL SUPPORT	34
-	2	2	2	2	-	2-21002-4	SCR, BTN SKT HD CAP 8-32 X .750	33
-	1	1	1	1	-	21024-5	WASHER, SPRG LOCK, REG NO 10	32
-	1	1	1	1	-	3-21000-4	SCR, SKT HD CAP 10-32 X .375	31
-	1	1	1	1	-	1-1320908-5	SPACER, STRIP GUIDE	30
-	1	1	1	1	-	1633091-3	ASSEMBLY, STRIP GUIDE	29
-	1	1	1	1	-	1-455888-0	SPACER, CRIMPER	28
-	1	1	1	1	-	1320928-1	PLATE, STRIP GUIDE	24
-	1	1	1	1	-	690472-2	STRIPPER	22
-	1	1	1	1	-	2-21000-7	SCR, SKT HD CAP 8-32 X .500	21
-	4	4	4	4	-	21024-4	WASHER, SPRG LOCK, REG NO 8	20
-	-	1	1	1	-	691353-1	STRIPPER	19
△	1	1	1	1	-	679625-1	SHEAR HOLDER, FRONT (NO CUT)	17
-	1	1	1	1	-	3-22280-3	SPRING, COMPRESSION	12
-	1	1	1	1	-	690461-1	STOP, SHEAR	11
△	-	1	1	1	-	690459-1	SHEAR HOLDER, FRONT	10
△	1	1	1	1	-	462006-7	FLOATING SHEAR, FRONT	9
△	1	1	1	1	-	3-1633107-2	ANVIL, COMBINATION .062	8
-	1	1	1	1	-	240641-5	SPACER	7
-	1	1	1	1	-	2-455889-0	DEPRESSOR, SHEAR	5
-	1	1	1	1	-	1-238011-0	BLOCK, CRIMPER SPACER	4
△	1	1	1	1	-	6-456135-5	CRIMPER, INSULATION O PREMIUM	3
△	1	1	1	1	-	1-455888-1	SPACER, CRIMPER	2
△	1	1	1	1	-	1-456403-2	CRIMPER, WIRE PREMIUM	1

INCHES	TOLERANCES UNLESS OTHERWISE SPECIFIED:	APPROVED	DATE	DESCRIPTION	ITEM NO
0 PLC	±	APPROVED	24FEB2007	DESCRIPTION	
1 PLC	±0.1	DATE	24FEB2007	DESCRIPTION	
2 PLC	±0.01	DATE	24FEB2007	DESCRIPTION	
3 PLC	±0.001	DATE	24FEB2007	DESCRIPTION	
4 PLC	±0.0001	DATE	24FEB2007	DESCRIPTION	
ANGLES	±0.001	DATE	24FEB2007	DESCRIPTION	
FINISH		DATE	24FEB2007	DESCRIPTION	

Mouser Electronics

Authorized Distributor

Click to View Pricing, Inventory, Delivery & Lifecycle Information:

[TE Connectivity:](#)

[1852430-6](#)