

4

3

2

1

THIS DRAWING IS UNPUBLISHED.

RELEASED FOR PUBLICATION

© COPYRIGHT

ALL RIGHTS RESERVED.

LOC DIST

REVISIONS

| P | LTR | DESCRIPTION | DATE | DWN | APVD |
|---|-----|-------------|------|-----|------|
|   |     |             |      |     |      |
|   |     |             |      |     |      |
|   |     |             |      |     |      |
|   |     |             |      |     |      |

# REPLACED BY OCEAN STYLE APPLICATOR PART NUMBER

FOR REPLACEMENT PARTS FOR APPLICATOR REFER TO ADDITIONAL PAGE(S). SPARE PARTS KIT (IF LISTED) WILL REMAIN AVAILABLE.

THE REPLACEMENT OCEAN STYLE APPLICATOR HAS THE SAME TERMINATOR/PRESS INTERFACE AS APPLICATOR

|   |        |                  |   |           |            |
|---|--------|------------------|---|-----------|------------|
| THIS DRAWING IS A CONTROLLED DOCUMENT.  |        | DWN              |  TE Connectivity |           |            |
| DIMENSIONS:   |        | CHK              |   |           |            |
| TOLERANCES UNLESS OTHERWISE SPECIFIED:  |        | APVD             | NAME  |           |            |
|  |        | PRODUCT SPEC     | RESTRICTED TO   |           |            |
|   |        | APPLICATION SPEC | SIZE  | CAGE CODE | DRAWING NO |
| MATERIAL  | FINISH | WEIGHT           | A3  | C-        |            |
|   |        | SCALE            | SHEET   | OF        | REV        |

THIS DRAWING IS UNPUBLISHED. RELEASED FOR PUBLICATION 20  
 COPYRIGHT © BY TYCO ELECTRONICS CORPORATION. ALL RIGHTS RESERVED.

| FEED FINGER |               | SET UP GAGE |  | LOC | DIST | REVISIONS |             |      |    |      |
|-------------|---------------|-------------|--|-----|------|-----------|-------------|------|----|------|
| 1901694-1   |               | 1901040-1   |  | A   | 66   | REV       | DESCRIPTION | DATE | BY | APPV |
| A           | RELEASED      |             |  |     |      | 08AUG2007 | ROW         | NED  |    |      |
| B           | ECR-07-020002 |             |  |     |      | 23AUG2007 | GH          | ND   |    |      |

| PART NUMBER | REV | DESCRIPTION        | PROGRAMMED MEMORY CHIP |
|-------------|-----|--------------------|------------------------|
| 1911102-1   | B   | CUTS CARRIER       | 8-1911102-1            |
| 1911102-6   | B   | CONTINUOUS CARRIER | 8-1911102-6            |
| 7-1911102-1 | B   | -1 AND SPARE PARTS | 9-1911102-1            |
| 7-1911102-6 | B   | -6 AND SPARE PARTS | 9-1911102-6            |
| 7-1911102-7 | A   | SPARE PARTS KIT    | -                      |

| APPLICATOR DATA                |               |      |
|--------------------------------|---------------|------|
| CRIMP                          | SIZE          | TYPE |
| WIRE                           | .110 [2.80mm] | F    |
| INSUL                          | .260 [6.60mm] | O    |
| APPL INSTRUCTIONS<br>408-10135 |               |      |

| TERMINAL DATA: TE TERMINAL                  |                            | TYCO ELECTRONICS CRIMP SPEC |
|---|----------------------------|-----------------------------|
| TERMINAL NAME: STANDARD-POWER-TIMER CONTACT |                            |                             |
| WIRE STRIP LENGTH                           | INSULATION DIAMETER RANGE  |                             |
| 5.0-5.6 mm [1.96-.220 IN]                   | 2.20-3.70mm [.086-.145 IN] |                             |
| TERMINAL APPL SPEC                          | 114-18037 (A)              | -                           |
|   | 114-18388 (B)              | -                           |

| TERMINALS APPLIED |               |          |         |
|-------------------|---------------|----------|---------|
| TE TERMINAL       | TE SEAL       | TE SEAL  | TE SEAL |
| 969042-1 (A)      | 1241414-3 (B) | 963244-1 | 1394511 |
| 1241414-1 (B)     | -             | 963245-1 | -       |

| WIRE SIZE          | CRIMP HEIGHT         |
|--------------------|----------------------|
|                    | mm [INCH]            |
| 2.5mm <sup>2</sup> | 2.04±.05 [.080±.002] |
| 2mm <sup>2</sup>   | 1.90±.05 [.075±.002] |
| 1.5mm <sup>2</sup> | 1.76±.05 [.069±.002] |

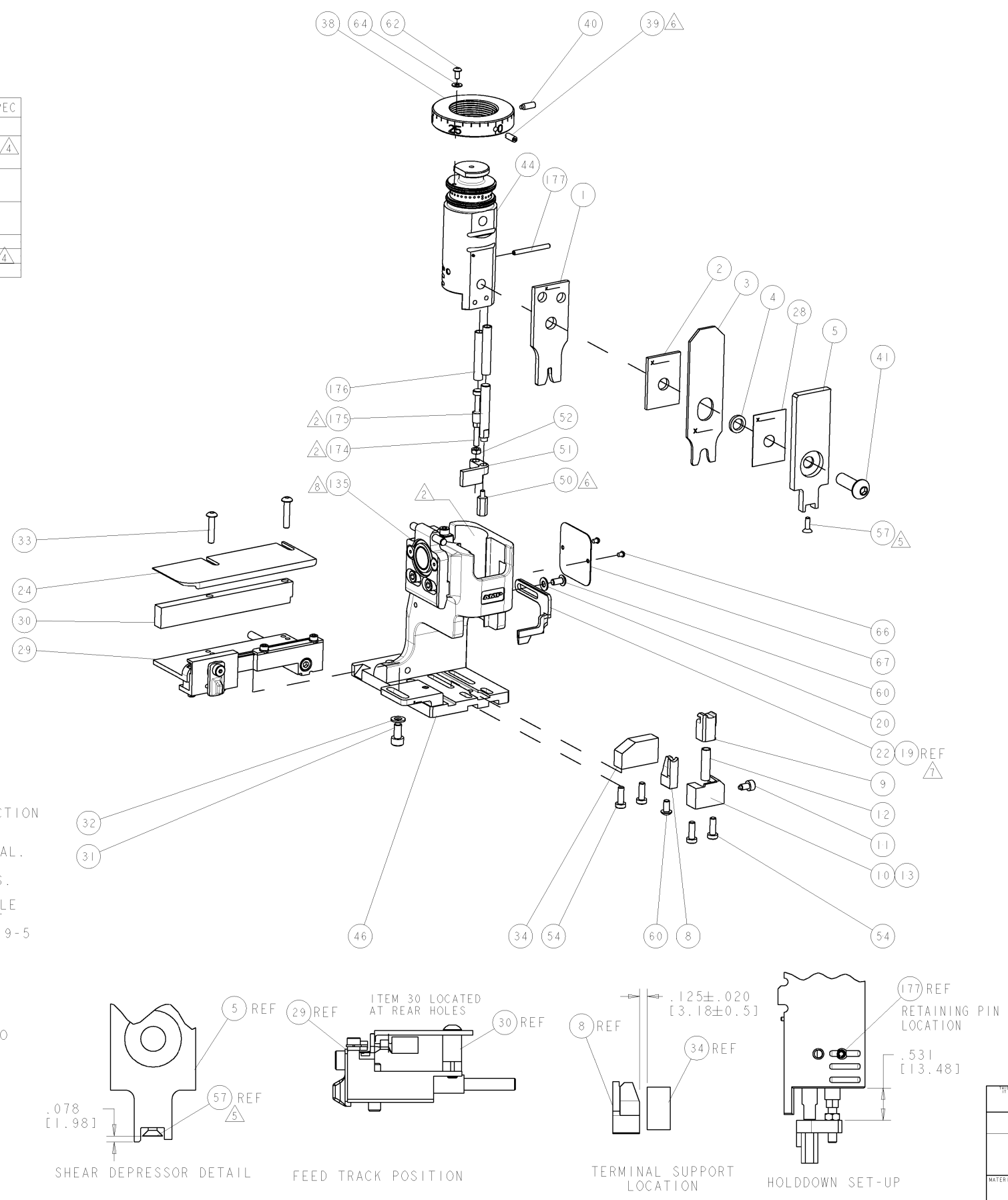

| REV | QTY | DESCRIPTION | ITEM NO                        |                                     |         |  |  |  |  |  |
|-----|-----|-------------|--------------------------------|-------------------------------------|---------|--|--|--|--|--|
| -   | 1   | 1-993111-6  | PIN, SLOTTED SPRING 3.0 X 30.0 | 177                                 |         |  |  |  |  |  |
| -   | 2   | 3-22280-7   | SPRING, COMPRESSION            | 176                                 |         |  |  |  |  |  |
| -   | 1   | 1752353-1   | GUIDE PIN, HOLDDOWN            | 175                                 |         |  |  |  |  |  |
| -   | 1   | 1901680-1   | GUIDE PIN, HOLDDOWN            | 174                                 |         |  |  |  |  |  |
| -   | REF | REF         | SEE TABLE                      | 135                                 |         |  |  |  |  |  |
| -   | 1   | 1633565-1   | DOCUMENTATION PACKAGE          | 71                                  |         |  |  |  |  |  |
| -   | 1   | 1901048-1   | TAG, IDENTIFICATION            | 67                                  |         |  |  |  |  |  |
| -   | 2   | 21017-1     | SCREW, DRIVE                   | 66                                  |         |  |  |  |  |  |
| -   | 1   | 18028-1     | WASHER, FLAT, REG M3           | 64                                  |         |  |  |  |  |  |
| -   | 1   | 1655785-9   | SCR, BTN SKT HD CAP (M3 X 6)   | 62                                  |         |  |  |  |  |  |
| -   | 2   | 2           | 1655785-1                      | SCR, BTN SKT HD CAP (M4 X 8)        | 60      |  |  |  |  |  |
| -   | 1   | 1           | 985575-3                       | SCR, FLT SKT HD CAP M3 X 10.0       | 57      |  |  |  |  |  |
| -   | 4   | 4           | 1655783-3                      | SCR, CAP, SOC HD, LOW HEAD, M4 X 12 | 54      |  |  |  |  |  |
| -   | 1   | 1           | 1-18030-0                      | NUT, HEX, REG M3.5                  | 52      |  |  |  |  |  |
| -   | 1   | 1           | 1901681-1                      | HOLDDOWN, TERMINAL                  | 51      |  |  |  |  |  |
| -   | 1   | 1           | 3-1752354-5                    | STANDOFF, HOLD-DOWN                 | 50      |  |  |  |  |  |
| -   | 1   | 1           | 1752300-1                      | SF SYSTEM III APPLICATOR            | 46      |  |  |  |  |  |
| -   | 1   | 1           | 1752308-1                      | RAM                                 | 44      |  |  |  |  |  |
| -   | 1   | 1           | 2-1655785-3                    | SCR, BTN SKT HD CAP (M8 X 25)       | 41      |  |  |  |  |  |
| -   | 1   | 1           | 993002-4                       | SCREW, SET, SFT TIP                 | 40      |  |  |  |  |  |
| -   | 1   | 1           | 1962043-1                      | PLUNGER, BALL, METRIC               | 39      |  |  |  |  |  |
| -   | 1   | 1           | 1752309-2                      | RING, INSULATION CRIMP              | 38      |  |  |  |  |  |
| -   | 1   | 1           | 1-1752356-2                    | SUPPORT, TERMINAL                   | 34      |  |  |  |  |  |
| -   | 2   | 2           | 3-1655785-3                    | SCR, BTN SKT HD CAP (M4 X 20)       | 33      |  |  |  |  |  |
| -   | 1   | 1           | 18028-3                        | WASHER, FLAT, REG M5                | 32      |  |  |  |  |  |
| -   | 1   | 1           | 5-1655316-3                    | SCR, SKT HD CAP, M5 X 10.0          | 31      |  |  |  |  |  |
| -   | 1   | 1           | 1-1320908-2                    | SPACER, STRIP GUIDE                 | 30      |  |  |  |  |  |
| -   | 1   | 1           | 1901087-3                      | ASSEMBLY, STRIP GUIDE               | 29      |  |  |  |  |  |
| -   | 1   | 1           | 455888-3                       | SPACER, CRIMPER                     | 28      |  |  |  |  |  |
| -   | 1   | 1           | 1320928-3                      | PLATE, STRIP GUIDE                  | 24      |  |  |  |  |  |
| -   | 1   | 1           | 1976045-1                      | STRIPPER                            | 22      |  |  |  |  |  |
| -   | 1   | 1           | 18028-2                        | WASHER, FLAT, REG M4                | 20      |  |  |  |  |  |
| -   | REF | REF         | REF                            | STRIPPER                            | 19      |  |  |  |  |  |
| -   | 1   | 1           | 1338684-2                      | SHEAR HOLDER, FRONT                 | 13      |  |  |  |  |  |
| -   | 1   | 1           | 3-22280-3                      | SPRING, COMPRESSION                 | 12      |  |  |  |  |  |
| -   | 1   | 1           | 356885-5                       | STOP, SHEAR                         | 11      |  |  |  |  |  |
| -   | 1   | 1           | 1-1320921-0                    | SHEAR HOLDER, FRONT, CUT            | 10      |  |  |  |  |  |
| -   | 1   | 1           | 318707-1                       | FLOATING SHEAR, FRONT               | 9       |  |  |  |  |  |
| -   | 1   | 2           | 1333229-2                      | ANVIL, COMBINATION                  | 8       |  |  |  |  |  |
| -   | 1   | 1           | 1-1338680-2                    | DEPRESSOR, SHEAR                    | 5       |  |  |  |  |  |
| -   | 1   | 1           | 238011-7                       | BLOCK, CRIMPER SPACER               | 4       |  |  |  |  |  |
| -   | 1   | 2           | 8-683454-4                     | CRIMPER, INSULATION O               | 3       |  |  |  |  |  |
| -   | 1   | 1           | 2-455888-2                     | SPACER, CRIMPER                     | 2       |  |  |  |  |  |
| -   | 1   | 2           | 456408-3                       | CRIMPER, WIRE PREMIUM               | 1       |  |  |  |  |  |
| -77 | -76 | -71         | -6                             | -1                                  | PART NO |  |  |  |  |  |

- 1 RECOMMENDED SPARE PARTS.
- 2 GREASE BEARING SURFACES LIGHTLY.
- 3 LUBRICATE DAILY PER THE APPLICATOR INSTRUCTION SHEET SUPPLIED WITH THE APPLICATOR.
- 4 THIS APPLICATOR APPLIES TERMINAL WITH A SEAL. WIRE INSULATION DIA IS DEPENDENT ON SEAL BEING APPLIED. SEE APPL. SPEC. FOR DETAILS.
- 5 APPLY TORQ-SEAL IN ALLEN SOCKET TO FILL HOLE AFTER FLAT HD HAS BEEN ADJUSTED TO CORRECT HEIGHT AT QUALIFICATION. APPLY P/N 1-23419-5 LOCTITE(R) TO THREADS.
- 6 APPLY P/N 1-23419-5 LOCTITE(R) TO THREADS.
- 7 ITEM 19 - OPTIONAL STRIPPER FOR BENCH MACHINE APPLICATION.
- 8 APPLICATOR SPECIFIC DATA TO BE ENTERED INTO BLANK MEMORY CHIP AT ASSEMBLY.

| DIMENSIONS: |   | TOLERANCES UNLESS OTHERWISE SPECIFIED: |   | APPROVED:    |           | DATE: |  |
|-------------|---|--|---|--------------|-----------|-------|--|
| INCHES [mm] |   |  |   |              |           |       |  |
| 0 PLC       | ± | 0.0005                                 | ± | R. O. WILSON | 13JUN2007 |       |  |
| 1 PLC       | ± | 0.0010                                 | ± | R. O. WILSON | 14JUN2007 |       |  |
| 2 PLC       | ± | 0.0015                                 | ± | T. ELAIN     | 14JUN2007 |       |  |
| 3 PLC       | ± | 0.0020                                 | ± |              |           |       |  |
| 4 PLC       | ± | 0.0025                                 | ± |              |           |       |  |

|                  |  |           |  |              |  |       |  |
|------------------|--|-----------|--|--------------|--|-------|--|
| CUSTOMER DRAWING |  | SCALE 3:5 |  | SHEET 1 OF 1 |  | REV B |  |
|------------------|--|-----------|--|--------------|--|-------|--|

# Mouser Electronics

Authorized Distributor

Click to View Pricing, Inventory, Delivery & Lifecycle Information:

[TE Connectivity:](#)

[1911102-6](#)