

4

3

2

1

THIS DRAWING IS UNPUBLISHED. RELEASED FOR PUBLICATION
 © COPYRIGHT ALL RIGHTS RESERVED.

LOC	DIST	REVISIONS			
P	LTR	DESCRIPTION	DATE	DWN	APVD
	A2	ECR-14-010821	18JUL2014	GK	HMR

REPLACED BY OCEAN STYLE APPLICATOR PART NUMBER 2266266-1

FOR REPLACEMENT PARTS FOR APPLICATOR 1855369
 REFER TO ADDITIONAL PAGE(S). SPARE PARTS KIT (IF LISTED)
 WILL REMAIN AVAILABLE.

THE REPLACEMENT OCEAN STYLE APPLICATOR HAS THE
 SAME TERMINATOR/PRESS INTERFACE AS APPLICATOR
 1855369

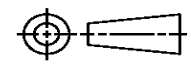
THIS DRAWING IS A CONTROLLED DOCUMENT.		DWN	GOPALAKRISHNA HV		
DIMENSIONS:		CHK	RAGHAVENDRA		
		APVD	RAGHAVENDRA		
TOLERANCES UNLESS OTHERWISE SPECIFIED:		PRODUCT SPEC	NAME		
0 PLC	±	APPLICATION SPEC	FINE ADJUST SIDE FEED HDM APPLICATOR		
1 PLC	±		SIZE	CAGE CODE	DRAWING NO
2 PLC	±		A3		©- 1855369
3 PLC	±				RESTRICTED TO
4 PLC	±				
ANGLES	±	WEIGHT			
MATERIAL	FINISH	CUSTOMER DRAWING	SCALE	SHEET 1 OF 2	REV A2



PART NUMBER	REV	FIRST USED	POWER UNIT	FEED TYPE	DESCRIPTION
1855369-1	A	122500-1	LEADMAKER	POST FEED	CUTS CARRIER
1855369-2	A	565435-5	BENCH MODEL K	PRE FEED	CUTS CARRIER
1855369-3	A	354500-1	BENCH MODEL G	PRE FEED	CUTS CARRIER
1855369-6	A	122500-1	LEADMAKER	POST FEED	CONTINUOUS CARRIER
7-1855369-7	A	-	-	-	SPARE PARTS

- △ RECOMMENDED SPARE PARTS
- △ GREASE LIGHTLY
- △ GUARD MUST BE IN PLACE WHEN OPERATING APPLICATOR IN A BENCH MACHINE

*** WARNING**
 ON INSTALLATION, SET WIRE DISC TO LARGEST WIRE SIZE SETTING. USE OF SETTINGS BELOW MIN. REQUIRED CRIMP HEIGHT SETTING WILL CAUSE DAMAGE TO CRIMP TOOLING.

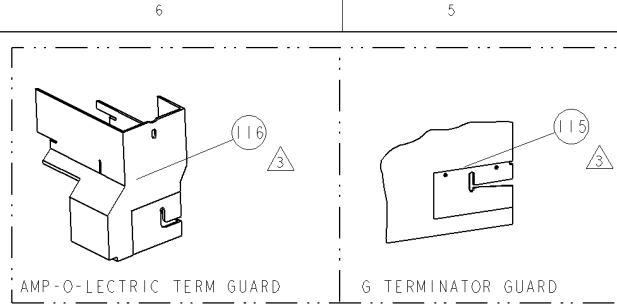

TERMINAL NAME: 1.2mm GET FEMALE TERMINAL		TE TERMINAL - TE CRIMP SPECS		REF SETTING
1924880	-			B8
-	-	CRIMP HEIGHT		C7
-	-	1.42mm+ .05/- .05 [.056+ .002/- .002]	1.5mm2	-
-	-	1.31mm+ .05/- .05 [.052+ .002/- .002]	16 AWG	-
-	-	CRIMP SIZE		-
-	-	WIRE	1.96mm [.077]	F
-	-	INSUL	2.16mm [.085]	O
-	-	FEED	8.000	Ø 2.4mm MAX
WIRE STRIP LENGTH	TERM APPL SPEC	APPLICATOR INSTRUCTIONS		SET UP GAGE
3.700-4.100	114-13236	408-8040		458637-1

LOC	REV	DESCRIPTION	DATE	BY	APPV
A	66	PRODUCT RELEASE	14JUL2008	CMR	TE
A	1	ECR-10-010049	11MAY2010	KH	TE

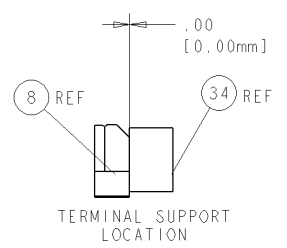
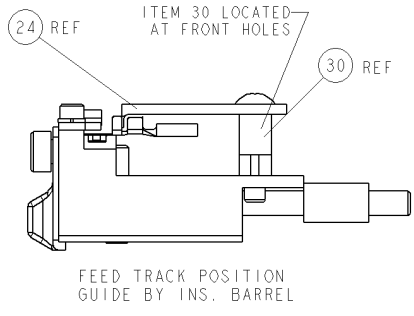
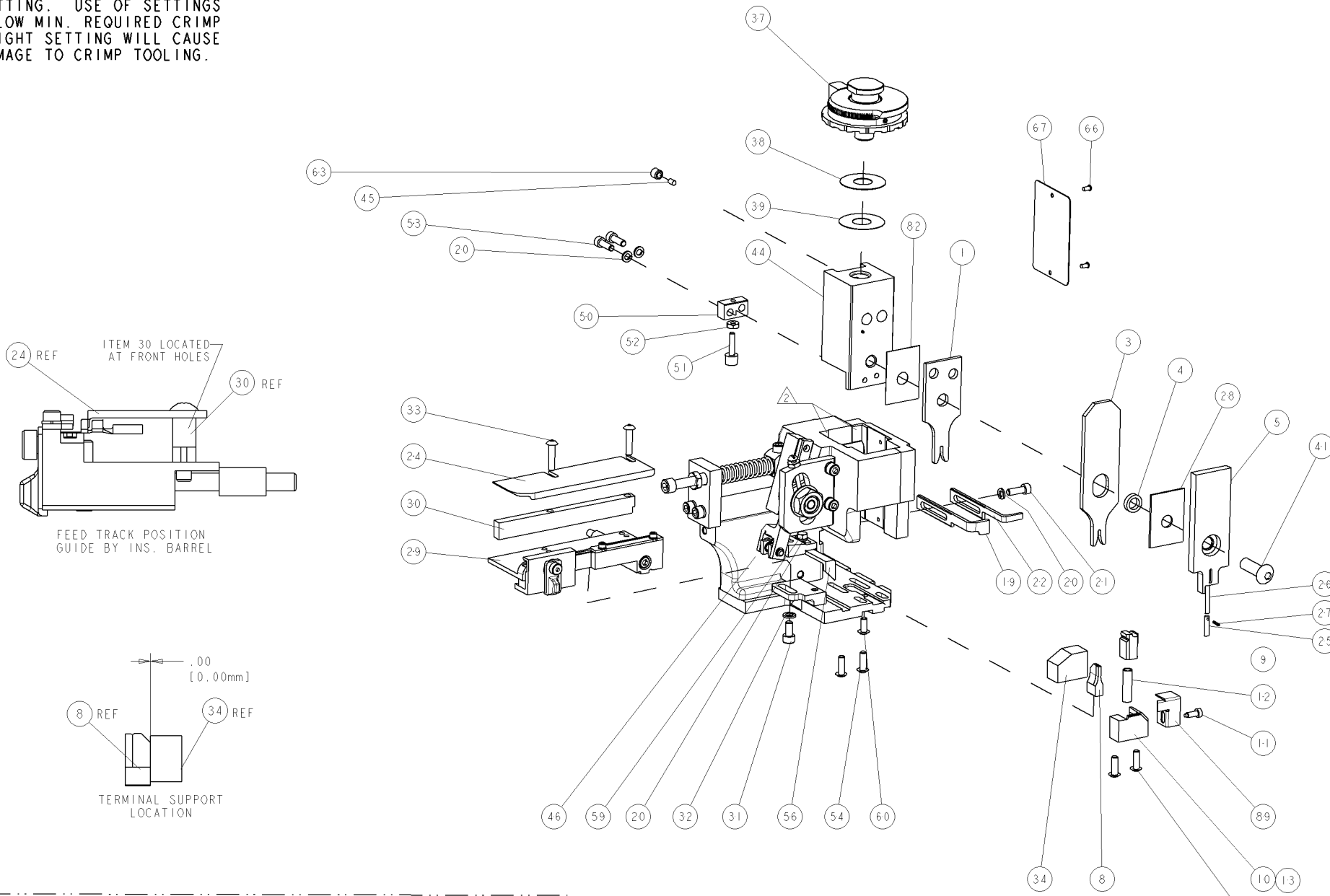

△	-	-	-	REF	-	455749-1	GUARD WINDOW	116
△	-	-	-	REF	-	679532-1	INSERT, GUARD	115
-	-	-	-	-	-	1-21002-7	SCR, BTN SKT HD CAP 6-32 X .375	91
-	-	-	-	-	-	318563-1	GUARD, FRONT CHIP	89
-	-	-	-	-	-	455888-1	SPACER, CRIMPER	82
-	-	-	-	-	-	4088040	SF APPL INST 408-8040	72
-	-	-	-	-	-	217238-1	GENERAL INSTRUCTION PKG	71
-	-	-	-	-	-	461264-5	PLATE, IDENTIFICATION	67
-	-	-	-	-	-	21017-2	SCREW, DRIVE	66
-	-	-	-	-	-	21009-2	SCR, SET, SELF LOCKING 1/4-20 X .250	63
-	-	-	-	-	-	22733-8	SCR, BHSC, SELF-LOCKING, 8-32 X .375	60
-	-	-	-	-	-	2-22603-0	SCR, HEX HD CAP 8-32 X .312	59
-	-	-	-	-	-	458537-2	PAWL, FEED	56
-	-	-	-	-	-	2-21002-2	SCR, BTN SKT HD CAP 8-32 X .500	54
-	-	-	-	-	-	2-21000-7	SCR, SKT HD CAP 8-32 X .500	53
-	-	-	-	-	-	21018-5	NUT, HEX, REG 6-32	52
-	-	-	-	-	-	811242-2	BUMPER, HOLD DOWN	51
-	-	-	-	-	-	690753-1	SPACER, TONKER	50
-	-	-	-	-	-	690602-6	CAM, PRE FEED, 1 5/8	49
-	-	-	-	-	-	690602-5	CAM, PRE FEED, 1 1/8	48
-	-	-	-	-	-	690501-4	CAM, POST-FEED 1 5/8	47
-	-	-	-	-	-	459456-1	APPL. BASIC SUB ASSY (SIDE WISE MOCA)	46
-	-	-	-	-	-	690191-1	PLUG, NYLON	45
-	-	-	-	-	-	455673-1	RAM, SIDE FEED	44
-	-	-	-	-	-	7-21002-9	SCR, BTN SKT HD CAP 5/16-24 X 1.00	41
-	-	-	-	-	-	690125-1	SHIM SUB-ASSY	39
-	-	-	-	-	-	1-469367-0	SHIM	38
-	-	-	-	-	-	879103-3	FINE ADJUST HEAD ASSEMBLY	37
-	-	-	-	-	-	2-690786-3	TERMINAL SUPPORT	34
-	-	-	-	-	-	2-21002-4	SCR, BTN SKT HD CAP 8-32 X .750	33
-	-	-	-	-	-	21024-5	WASHER, SPRG LOCK, REG NO 10	32
-	-	-	-	-	-	3-21000-4	SCR, SKT HD CAP 10-32 X .375	31
-	-	-	-	-	-	1320908-4	SPACER, STRIP GUIDE	30
-	-	-	-	-	-	1633091-3	ASSEMBLY, STRIP GUIDE	29
-	-	-	-	-	-	1-455888-0	SPACER, CRIMPER	28
-	-	-	-	-	-	21028-2	PIN, SLOTTED SPRING .062 X .250	27
-	-	-	-	-	-	5-547505-2	SPRING, COMPRESSION	26
-	-	-	-	-	-	854769-1	HOLDER, INS	25
-	-	-	-	-	-	1320928-1	PLATE, STRIP GUIDE	24
-	-	-	-	-	-	690472-2	STRIPPER	22
-	-	-	-	-	-	2-21000-7	SCR, SKT HD CAP 8-32 X .500	21
-	-	-	-	-	-	21024-4	WASHER, SPRG LOCK, REG NO 8	20
-	-	-	-	-	-	691353-1	STRIPPER	19
-	-	-	-	-	-	679625-1	SHEAR HOLDER, FRONT (NO CUT)	13
-	-	-	-	-	-	3-22280-3	SPRING, COMPRESSION	12
-	-	-	-	-	-	690461-1	STOP, SHEAR	11
-	-	-	-	-	-	690459-1	SHEAR HOLDER, FRONT	10
-	-	-	-	-	-	462006-1	FLOATING SHEAR, FRONT	9
-	-	-	-	-	-	7-1633535-5	ANVIL, COMBINATION	8
-	-	-	-	-	-	-	-	7
-	-	-	-	-	-	-	-	6
-	-	-	-	-	-	854772-1	DEPRESSOR, SHEAR	5
-	-	-	-	-	-	238011-2	BLOCK, CRIMPER SPACER	4
-	-	-	-	-	-	5-1583690-9	CRIMPER, INSUL O	3
-	-	-	-	-	-	-	-	2
-	-	-	-	-	-	2-1633588-5	CRIMPER, WIRE	1

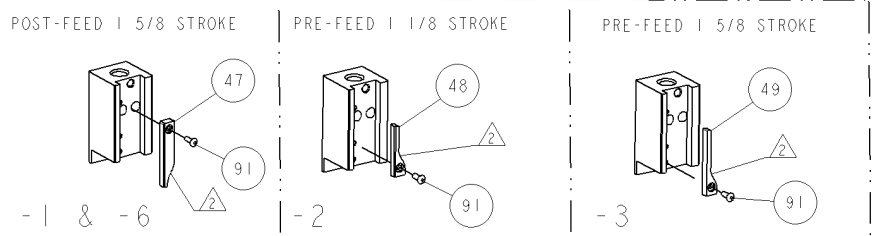

DIMENSIONS	TOLERANCES UNLESS OTHERWISE SPECIFIED	APPROVALS	DESCRIPTION
INCHES	0 PLC ±.01 1 PLC ±.01 2 PLC ±.01 3 PLC ±.001 4 PLC ±.0001 ANGLE	DWG: C. REICHELDEITER CH: T. ELBIN APPV: M. DEMING DATE: 09MAY2008 NAME: FINE ADJUST SIDE FEED HDM APPLICATOR PRODUCT SPEC: APPLICATION SPEC: MATERIAL: FINISH: WEIGHT: CUSTOMER DRAWING	Tyco Electronics Tyco Electronics Harrisburg, PA 17105-3608 SIZE: A CASE CODE: 00779 DRAWING NO: 1855369 RESTRICTED TO: SCALE: 3:5 SHEET 1 OF 1 REV: A1

CUSTOMER VIEWABLE ASSEMBLY

Mouser Electronics

Authorized Distributor

Click to View Pricing, Inventory, Delivery & Lifecycle Information:

[TE Connectivity:](#)

[1855369-2](#)