

PART NUMBER	REV	FIRST USED	TERMINATOR	DESCRIPTION
9-1855005-2	B	-	BENCH & LEAD	AIR FEED
9-1855005-3	B	-	BENCH	AIR FEED
7-1855005-2	A	-	-	SPARE PARTS KIT
7-1855005-6	A	-	-	SPARE PARTS KIT

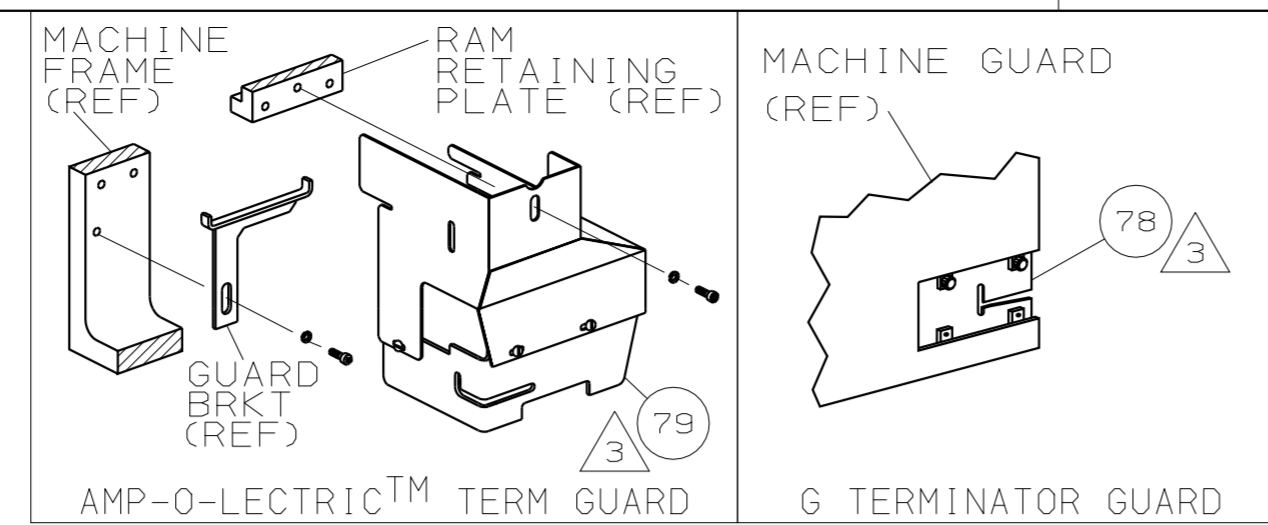

TERMINAL NAME: RING TERMINAL					
TYCO TERM PN	GROTE & HARTMANN TERMINAL	AMP CRIMP SPECS			
1572674		CRIMP HEIGHT	WIRE SIZE		
		3.89 ±0.05mm [0.153 ±.002]	6mm <sup>2</sup>		
GROTE & HARTMANN PN	C3	NOT	USED		
25923.212.004		NOT	USED		
		NOT	USED		
		NOT	USED		
CRIMP	SIZE	TYPE	RANGE		
WIRE	.250 [6.35mm]	F	6mm <sup>2</sup>		
INSUL	.310 [7.87mm]	F	6.35mm MAX		
WIRE STRIP LENGTH	TERM APPL SPEC	FEED	APPL INSTRUCTION	SET UP GAGE	LAYOUT
7.29mm-7.72mm	NONE	37.67mm	408-8039 & 408-8490	458638-1	L3091

-92	LEADMAKER & BENCH MODEL G		AIR FEED					
-93	BENCH MODEL K		AIR FEED					
-	-	1	-	-	C	692655-5	AIR FEED VALVE ASSY	70
-	-	1	-	1	C	1-460277-9	AIR FEED ASSY (2 INCH)	69
-	-	REF	-	-	A	24042-2	VALVE, SHUT OFF	68
-	-	REF	-	-	C	692655-6	AIR FEED VALVE ASSY	67
-	-	-	1	-	B	1-460277-5	AIR FEED ASSY (2 INCH)	66
-	-	2	2	-	A	3-21000-9	SCR,SHC(10-32x1.00)AIR ASSY	65
-	-	-	1	-	A	980285-2	ELBOW, SWIVEL 1/8 NPT - 1/4 T	64
-	-	-	1	-	A	23238-1	QUICK DISCONNECT	63
-	-	-	12.00	IN	A	27319-4	TUBING, POLY-FLO Ø.25	62
-	-	1	1	-	C	454220-1	CAP, RAM	61
-	-	1	1	-	D	453736-1	HOUSING	60
-	-	-	1	-	A	22374-7	VALVE, QUICK EXHAUST	59
-	-	-	1	-	A	22304-1	NIPPLE, HEX	58
-	-	1	1	-	B	460680-1	FEED FINGER ASSY	57
-	-	-	-	-	-	-	-	56
-	-	-	-	-	-	-	-	55
-	-	-	-	-	-	-	-	54
-	-	-	-	-	-	-	-	53
-	-	-	-	-	-	-	-	52
-	-	-	-	-	-	-	-	51
-	-	-	-	-	-	-	-	50
-	-	-	-	-	-	-	-	49
-	-	-	-	-	-	-	-	48
-	-	-	-	-	-	-	-	47
-	-	-	-	-	-	-	-	46
-	-	1	1	-	A	690191-1	PLUG, NYLON	45
-	-	1	1	-	C	455674-1	RAM	44
-	-	-	-	-	-	-	-	43
-	-	1	1	-	A	690686-2	BOLT, CRIMPER(5/16-24x1.00)	42
-	-	-	-	-	-	-	-	41
-	-	-	-	-	-	-	-	40
-	-	-	-	-	-	-	-	39
-	-	1	1	-	-	690125-1	SHIM SUBASSY	38
-	-	1	1	-	-	879103-2	FINE ADJUST HEAD SUBASSY	37
-	-	-	-	-	-	-	-	36
-	-	-	-	-	-	-	-	35
-	-	-	-	-	-	-	-	34
-	-	-	-	-	-	-	-	33
-	-	-	-	-	-	-	-	32
-	-	-	-	-	-	-	-	31
-	-	-	-	-	-	-	-	30
-	-	-	-	-	-	-	-	29
-	-	-	-	-	-	-	-	28
-	-	1	1	-	A	690455-2	STRIPPER	27
-	-	1	1	-	D	455676-2	PLATE, BASE	26
-	-	2	2	-	A	22354-8	DRAG, STUD	25
-	-	1	1	-	B	455678-1	PLATE, STRIP GUIDE	24
-	-	-	-	-	-	-	-	23
-	-	2	2	-	A	4-22281-1	SPRING, DRAG	22
-	-	-	-	-	-	-	-	21
-	-	1	1	-	A	454177-1	DRAG, STOCK	20
-	-	1	1	-	B	5-458030-8	GUIDE, STRIP (REAR)	19
-	-	1	1	-	C	5-458031-9	GUIDE, STRIP (FRONT)	18
-	-	-	-	-	-	-	-	17
-	-	-	-	-	-	-	-	16
-	-	1	1	-	C	6-240641-8	SPACER, SLUG BLADE	15
-	-	-	-	-	-	-	-	14
-	-	-	-	-	-	-	-	13
-	-	-	-	-	-	-	-	12
1	-	1	1	-	B	240644-1	PLATE, REAR SHEAR	11
-	-	2	2	-	C	2-240645-7	SPACER, SHEAR PLATE	10
1	-	1	1	-	B	240642-1	PLATE, FRONT SHEAR	9
1	1	1	1	-	D	7-356038-9	ANVIL	8
1	-	1	1	-	B	2-240651-9	BLADE, SLUG	7
-	-	-	-	-	-	-	-	6
-	-	1	1	-	C	4-240641-7	SPACER, SLUG BLADE	5
-	-	1	1	-	B	238009-5	SPACER, BLOCK CRIMPER	4
1	1	1	1	-	C	4-1424909-7	CRIMPER, INSULATION	3
-	-	1	1	-	B	1-455888-3	SPACER, CRIMPER	2
1	1	1	1	-	C	1-1752057-0	CRIMPER, WIRE	1

THIS DRAWING IS A CONTROLLED DOCUMENT.

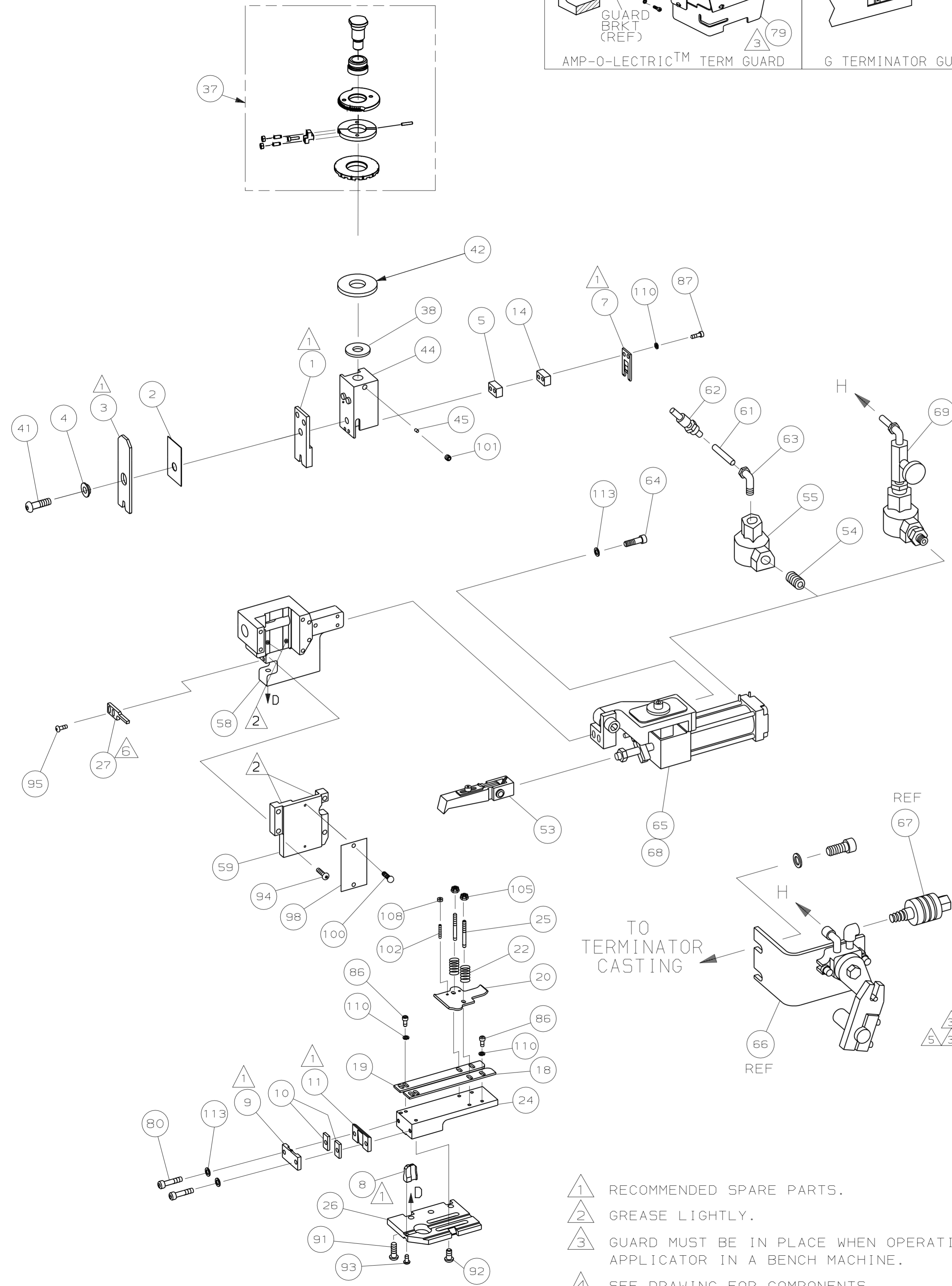

- 1 RECOMMENDED SPARE PARTS.
- 2 GREASE LIGHTLY.
- 3 GUARD MUST BE IN PLACE WHEN OPERATING APPLICATOR IN A BENCH MACHINE.
- 4 SEE DRAWING FOR COMPONENTS
- 5 ITEM 78 USED WITH G TERMINATOR ONLY.
- 6 STRIPPER INVERTED DURING ASSEMBLY.

QTY	REV	REV	REV	REV	U/M	DWG SIZE	PART NO	DESCRIPTION	ITEM NO
-	-	-	-	-	-	-	-	-	129
-	-	-	-	-	-	-	-	-	128
-	-	-	-	-	-	-	-	-	127
-	-	-	-	-	-	-	-	-	126
-	-	-	-	-	-	-	-	-	125
-	-	1	1	-	A		217238-1	GENERAL INSTRUCTION PACKAGE	124
-	-	1	1	-	-		4088039	EF APPL INST 408-8039	123
-	-	1	1	-	-		4088490	EF APPL INST 408-8490	122
-	-	-	-	-	-	-	-	-	121
-	-	-	-	-	-	-	-	-	120
-	-	-	-	-	-	-	-	-	119
-	-	-	-	-	-	-	-	-	118
-	-	-	-	-	-	-	-	-	117
-	-	-	-	-	-	-	-	-	116
-	-	-	-	-	-	-	-	-	115
-	-	-	-	-	-	-	-	-	114
-	-	4	4	-	A		21024-5	WASHER, LOCK (#10) AIR ASSY	113
-	-	-	-	-	-	-	-	-	112
-	-	4	4	-	A		21024-4	WASHER, LOCK (NO.8) SHEAR BL	111
-	-	-	-	-	-	-	-	-	110
-	-	2	2	-	A		21018-4	NUT, HEX (4-40) DRAG	109
-	-	-	-	-	-	-	-	-	108
-	-	-	-	-	-	-	-	-	107
-	-	2	2	-	A		21022-2	NUT, HEX SL (8-32) DRAG STUD	105
-	-	-	-	-	-	-	-	-	104
-	-	-	-	-	-	-	-	-	103
-	-	2	2	-	A		2-21006-6	SCR,SKT SET (4-40x.62) DRAG	102
-	-	1	1	-	A		21009-2	SCR,SKT SET (1/4-20x.25 )RAM	101
-	-	2	2	-	A		21017-2	SCR,DRIVE (#2x.19) ID PLATE	100
-	-	-	-	-	-	-	-	-	99
-	-	1	1	-	B		461264-5	PLATE, IDENTIFICATION	98
-	-	-	-	-	-	-	-	-	97
-	-	-	-	-	-	-	-	-	96
-	-	2	2	-	A		2-21002-2	SCR,BHC (8-32x.50) STRIPPER	95
-	-	4	4	-	A		2-21002-9	SCR,BHC (10-32x.75) CAP	94
-	-	1	1	-	A		22733-8	SCR,BHC (8-32x.38 LW) ANVIL	93
-	-	4	4	-	A		3-21002-3	SCR,BHC (1/4-20x.50) ST GD PL	92
-	-	3	3	-	A		2-22733-8	SCR,BHC (1/4-20x.62)H5G	91
-	-	-	-	-	-	-	-	-	90
-	-	-	-	-	-	-	-	-	89
-	-	-	-	-	-	-	-	-	88
-	-	2	2	-	A		3-21000-1	SCR,SHC (8-32x1.00) SLUG BLADE	87
-	-	4	4	-	A		2-21000-7	SCR,SHC (8-32x.50) STRIP GUIDE	86
-	-	-	-	-	-	-	-	-	85
-	-	-	-	-	-	-	-	-	84
-	-	-	-	-	-	-	-	-	83
-	-	-	-	-	-	-	-	-	82
-	-	-	-	-	-	-	-	-	81
-	-	2	2	-	A		3-21000-8	SCR,SHC (10-32x.88) SHEAR PL	80
-	-	1	-	-	A		455750-7	GUARD ASSY	79
-	-	-	-	-	A		354529-1	INSERT, GUARD	78
-	-	-	-	-	-	-	-	-	77
-	-	-	-	-	-	-	-	-	76
-	-	-	-	-	-	-	-	-	75
-	-	-	-	-	-	-	-	-	74
-	-	-	-	-	-	-	-	-	73
-	-	-	-	-	-	-	-	-	72
-	-	-	-	-	-	-	-	-	71
-76	-72	-93	-92	U/M	DWG SIZE		PART NO	DESCRIPTION	ITEM NO

LOC A  
DIST 66

QTY RECD PER ASSY PARTS LIST

DIMENSIONS IN INCHES. DO NOT SCALE PRINT. TOLERANCES UNLESS OTHERWISE SPECIFIED:  
 2 PLC DEC ±.25  
 3 PLC DEC ±.125  
 4 PLC DEC ±.0625  
 ANGLES ± -  
 SURF TEXTURE: ✓  
 REMOVE BURRS, BREAK SHARP EDGES R.015 MAX

MATL - HT TR - FIN -

DR B.HIGMAN 22FEB05 APP T.ELBIN 22FEB05  
 CHK 31MAR05 REL 31MAR05  
 G.BAILEY R.KNEPPER

**AMP** Tyco Electronics Harrisburg, PA 17105-3608

NAME END FEED HDM APPLICATOR MACHINE REF MINI APPL  
 SCALE - DWG NO 1855005 SHEET 1 OF 1 REV B

CAGE CODE 00779 CUSTOMER AND ASSEMBLY DRAWING

# Mouser Electronics

Authorized Distributor

Click to View Pricing, Inventory, Delivery & Lifecycle Information:

[TE Connectivity:](#)

[9-1855005-3](#)