

4

3

2

1

THIS DRAWING IS UNPUBLISHED. RELEASED FOR PUBLICATION
© COPYRIGHT ALL RIGHTS RESERVED.

LOC	DIST	REVISIONS			
P	LTR	DESCRIPTION	DATE	DWN	APVD
	A1	ECR-15-012201	08SEP2015	GK	SD

REPLACED BY OCEAN STYLE APPLICATOR PART NUMBER 2150584-2

FOR REPLACEMENT PARTS FOR APPLICATOR 1852464 REFER TO ADDITIONAL PAGE(S). SPARE PARTS KIT (IF LISTED) WILL REMAIN AVAILABLE.

THE REPLACEMENT OCEAN STYLE APPLICATOR HAS THE SAME TERMINATOR/PRESS INTERFACE AS APPLICATOR 1852464

THIS DRAWING IS A CONTROLLED DOCUMENT.		DWN	GOPALAKRISHNA HV		 TE Connectivity
DIMENSIONS:		CHK	GOPALAKRISHNA HV		
TOLERANCES UNLESS OTHERWISE SPECIFIED:		APVD	STOUGH DALE		NAME END FEED HDM APPLICATOR
0 PLC ±		PRODUCT SPEC			
1 PLC ±		APPLICATION SPEC			SIZE A3
2 PLC ±		WEIGHT	CAGE CODE	DRAWING NO	
3 PLC ±				©- 1852464	
4 PLC ±				SCALE	SHEET 1 OF 2 REV A1
ANGLES ±				CUSTOMER DRAWING	
MATERIAL	FINISH				

PART NUMBER	REV	FIRST USED	POWER UNIT	FEED TYPE
1852464-1	A	122500-1	LEADMAKER & BENCH MODEL G	POST FEED
1852464-2	A	565435-5	BENCH MODEL K	POST FEED
7-1852464-7	A	-	SPARE PARTS	-

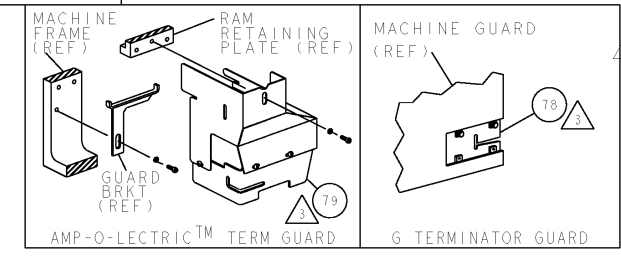

TYCO PN		MFR PN		EURAMTEC TERMINAL - AMP CRIMP SPECS	
1949348-1	-	W-ST-2000	-	CRIMP HEIGHT	WIRE SIZE
-	-	-	-	A .059±.002 [1.50±0.05mm]	16AWG
-	-	-	-	B .051±.002 [1.30±0.05mm]	18AWG
-	-	-	-	C .046±.002 [1.17±0.05mm]	20AWG
-	-	-	-	D -	-
-	-	-	-	CRIMP	SIZE
-	-	-	-	WIRE .080 [2.03mm]	F 20-16 AWG
-	-	-	-	INSUL .125 [3.18mm]	F ∅.100 MAX
WIRE STRIP LENGTH	TERM APPL SPEC	FEED	APPL INSTRUCTIONS	SET UP GAGE	
.171 - .186	NONE	.933	408-8039	458638-1	

REV	DATE	BY	CHKD	DESCRIPTION
A	11APR2007	BH	BH	RELEASED

- 1 RECOMMENDED SPARE PARTS
- 2 GREASE LIGHTLY
- 3 GUARD MUST BE IN PLACE WHEN OPERATING APPLICATOR IN A BENCH MACHINE
- 4 FEED OFF STABILIZER.

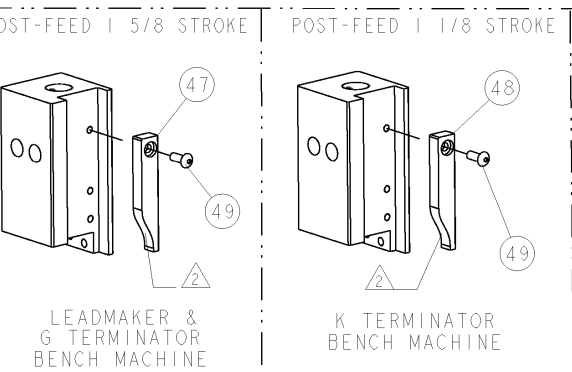
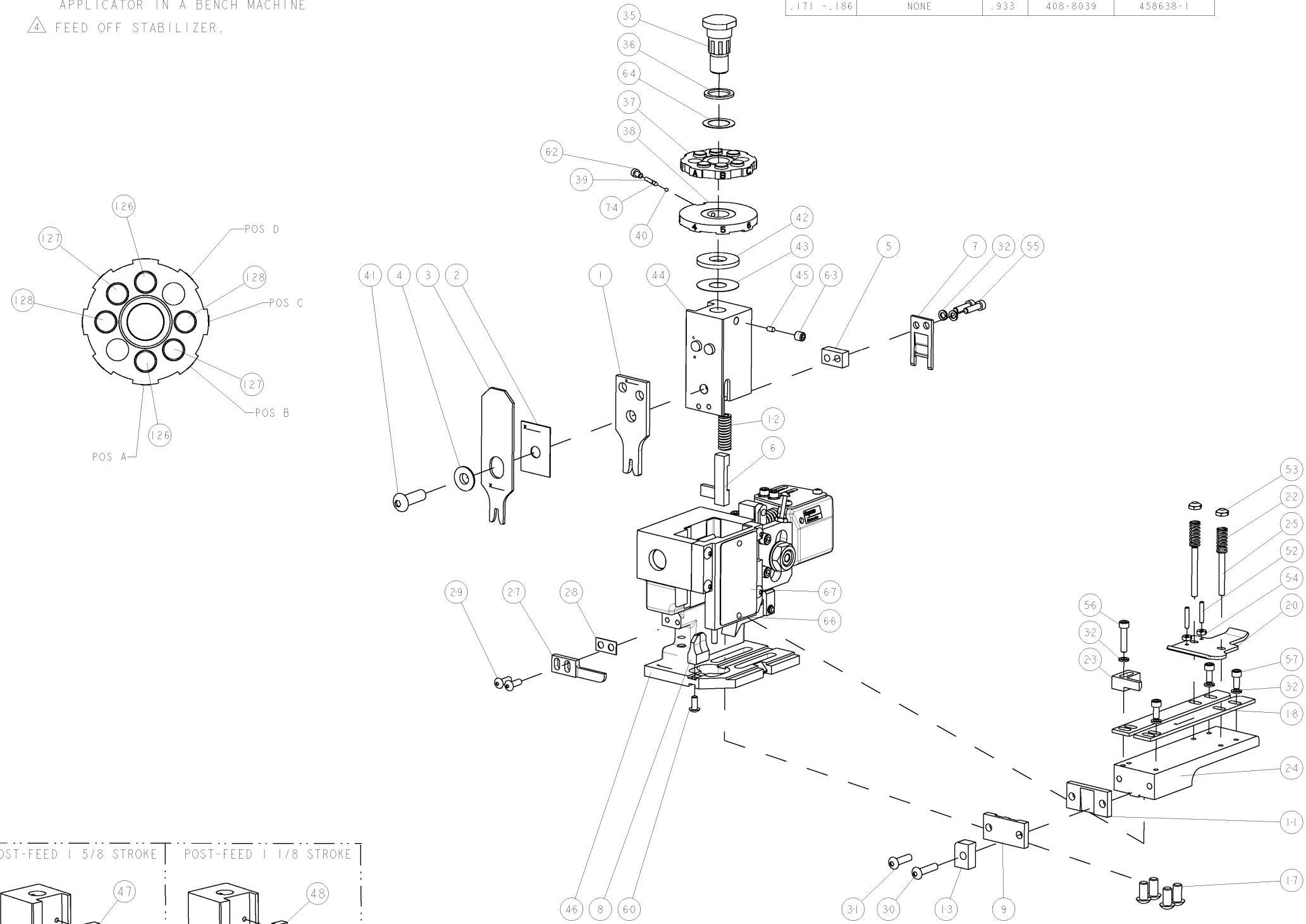

REV	DATE	BY	CHKD	DESCRIPTION	ITEM NO	
-	2	2	-	4-354779-2	PIN, WIRE DISC, .3200	128
-	2	2	-	3-354779-0	PIN, WIRE DISC, .3140	127
-	2	2	-	1-354779-4	PIN, WIRE DISC, .3060	126
3	REF	-	-	455745-1	GUARD WINDOW	79
3	-	REF	-	679532-1	INSERT, GUARD	78
-	1	1	-	690603-1	SPRING ASSIST AMP-O-MATOR APPLICATOR	74
-	1	1	-	217238-1	GENERAL INSTRUCTION PKG	72
-	1	1	-	4088039	EF APPL INST 408-8039	71
-	1	1	-	461264-1	PLATE, IDENTIFICATION	67
-	2	2	-	21017-2	SCREW, DRIVE	66
-	1	1	-	986950-1	WASHER, FLAT PRECISION	64
-	1	1	-	21009-2	SCR, SET, SELF LOCKING 1/4-20 X .250	63
-	1	1	-	23030-1	SCR, SKT HD CAP 6-32 X .25	62
-	1	1	-	22733-8	SCR, BHSC, SELF-LOCKING, 8-32 X .375	60
-	3	3	-	2-21000-6	SCR, SKT HD CAP 8-32 X .375	57
-	2	2	-	2-21000-9	SCR, SKT HD CAP 8-32 X .750	56
-	2	2	-	2-21000-8	SCR, SKT HD CAP 8-32 X .625	55
-	2	2	-	21018-4	NUT, HEX, REG 4-40	54
-	2	2	-	21022-2	NUT, LOCK, HEX, TORQUE, 8-32	53
-	2	2	-	2-21006-6	SCR, SET, CUP POINT 4-40 X .625	52
-	1	1	-	1-21002-7	SCR, BTN SKT CAP 6-32 X .375	49
-	1	-	-	690501-3	CAM, POST FEED, 1/8	48
-	-	1	-	690501-4	CAM, POST FEED, 1/8	47
-	1	1	-	458980-1	SUB ASSY, APPLICATOR FRAME	46
-	1	1	-	690191-1	PLUG, NYLON	45
-	1	1	-	455674-1	RAM	44
-	1	1	-	690125-1	SHIM SUB-ASSY	43
-	1	1	-	690124-1	WASHER, RAM (.115)	42
-	1	1	-	7-21002-9	SCR, BTN SKT HD CAP 5/16-24 X 1.00	41
-	1	1	-	23241-6	BALL, STEEL	40
-	1	1	-	690170-1	SPRING, COMPRESSION	39
-	1	1	-	690142-1	DISC, INSULATION	38
-	1	1	-	354777-1	WIRE DISC, ASSEMBLY	37
-	1	1	-	22480-5	SPRING, COMPRESSION	36
-	1	1	-	690212-1	POST, RAM	35
-	7	7	-	21024-4	WASHER, SPRG LOCK, REG NO 8	32
-	1	1	-	2-21002-9	SCR, BTN SKT HD CAP 10-32 X .750	31
-	1	1	-	3-21002-0	SCR, BTN SKT HD CAP 10-32 X .875	30
-	2	2	-	2-21002-2	SCR, BTN SKT HD CAP 8-32 X .500	29
-	1	1	-	1-690451-7	SPACER, STRIPPER	28
-	1	1	-	240639-1	STRIPPER (MACHINING)	27
-	2	2	-	22354-8	STUD, THREADED	25
-	1	1	-	455678-1	PLATE, STRIP GUIDE	24
-	1	1	-	240825-1	PLATE, STRIP HOLD DOWN	23
-	2	2	-	4-22281-1	SPRING, DRAG	22
-	1	1	-	454177-1	DRAG	20
-	2	2	-	454204-3	GUIDE, LOWER STRIP	18
-	4	4	-	3-21002-3	SCR, BTN SKT HD CAP 1/4-20 X .500	17
-	1	1	-	690481-1	SPACER, HOLD DOWN	13
-	1	1	-	23846-1	SPRING, DIE	12
-	1	1	-	240644-1	PLATE, REAR SHEAR	11
-	1	1	-	690482-6	PLATE, FRONT SHEAR	9
-	1	1	-	1-1633248-2	ANVIL, COMBINATION	8
-	1	1	-	690474-6	BLADE, SLUG	7
-	1	1	-	455892-1	HOLD DOWN, TERMINAL	6
-	1	1	-	6-240641-8	SPACER	5
-	1	1	-	1-238009-4	BLOCK, FL CRIMPER SPACER	4
-	1	1	-	8-683453-9	CRIMPER, INSULATION PREMIUM	3
-	1	1	-	455888-7	SPACER, CRIMPER	2
-	1	1	-	1-456405-3	CRIMPER, WIRE PREMIUM	1

REV	DATE	BY	CHKD	DESCRIPTION	ITEM NO
-77	-2	-1	U/M	PART NO	

DIMENSIONS: INCHES		TOLERANCES UNLESS OTHERWISE SPECIFIED:		TYPICAL DIMENSIONS	
0 PLC	±	0 PLC	±	0.001	±
1 PLC	±	1 PLC	±	0.001	±
2 PLC	±	2 PLC	±	0.001	±
3 PLC	±	3 PLC	±	0.001	±
4 PLC	±	4 PLC	±	0.001	±
MATERIAL:		FINISH:		WEIGHT:	

DATE	26MAR2007	DESIGNER	B. HIGMAN	DATE	26MAR2007	DESIGNER	B. HIGMAN
DATE	26MAR2007	DESIGNER	B. HIGMAN	DATE	26MAR2007	DESIGNER	B. HIGMAN
DATE	26MAR2007	DESIGNER	B. HIGMAN	DATE	26MAR2007	DESIGNER	B. HIGMAN
TITELBLIN		NAME		END FEED HDM APPLICATOR		RESTRICTED TO	
APPLICATION SPEC		SIZE		CAGE CODE		DRAWING NO	
		A		00779		1852464	
CUSTOMER DRAWING		SCALE		3:5		SHEET 1 OF 1	

Mouser Electronics

Authorized Distributor

Click to View Pricing, Inventory, Delivery & Lifecycle Information:

[TE Connectivity:](#)

[1852464-2](#)