

PART NUMBER	REV	FIRST USED
1852048-1	B	122500-1
1852048-2	B	565435-5
1852048-3	B	354500-1

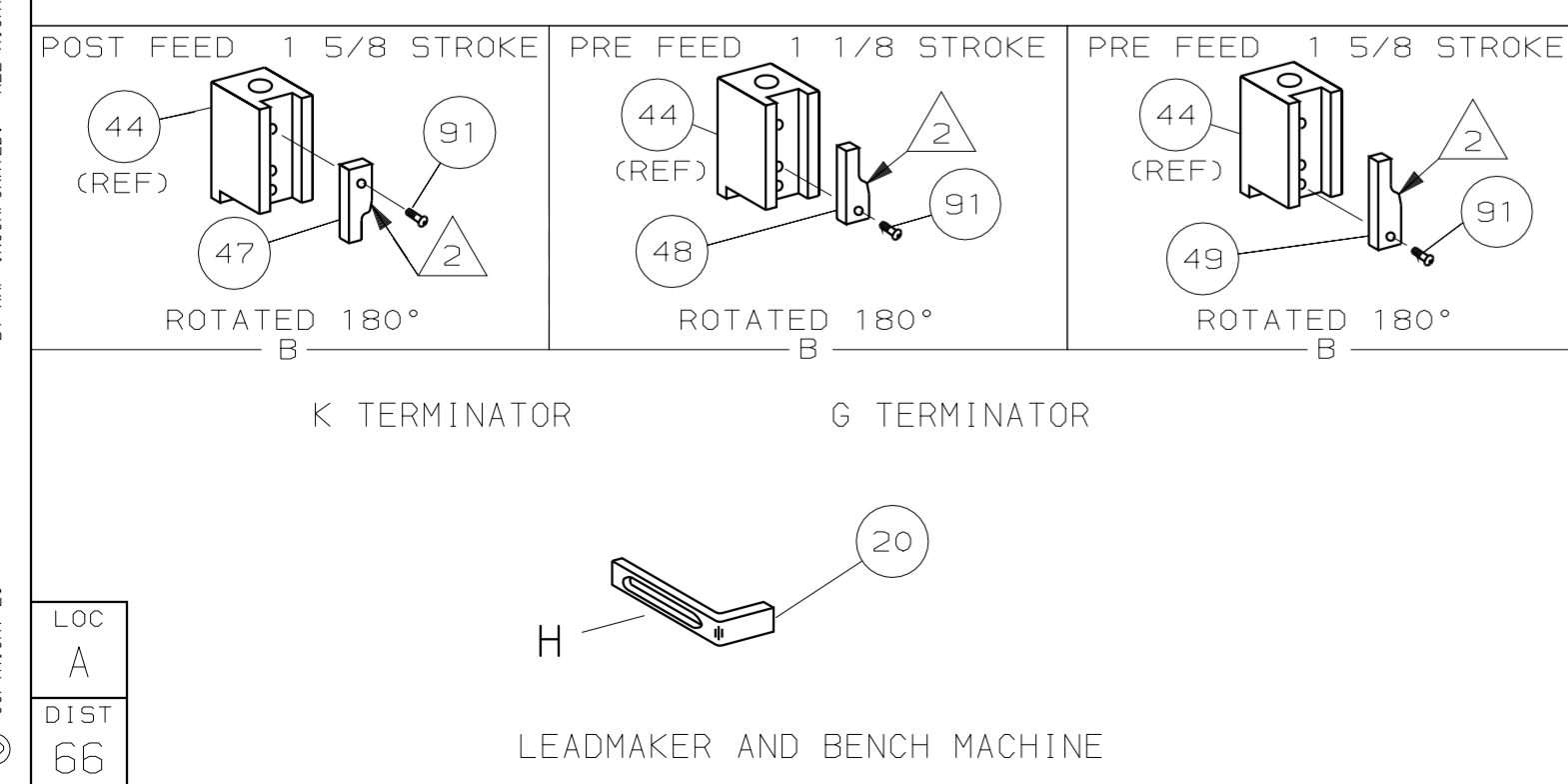
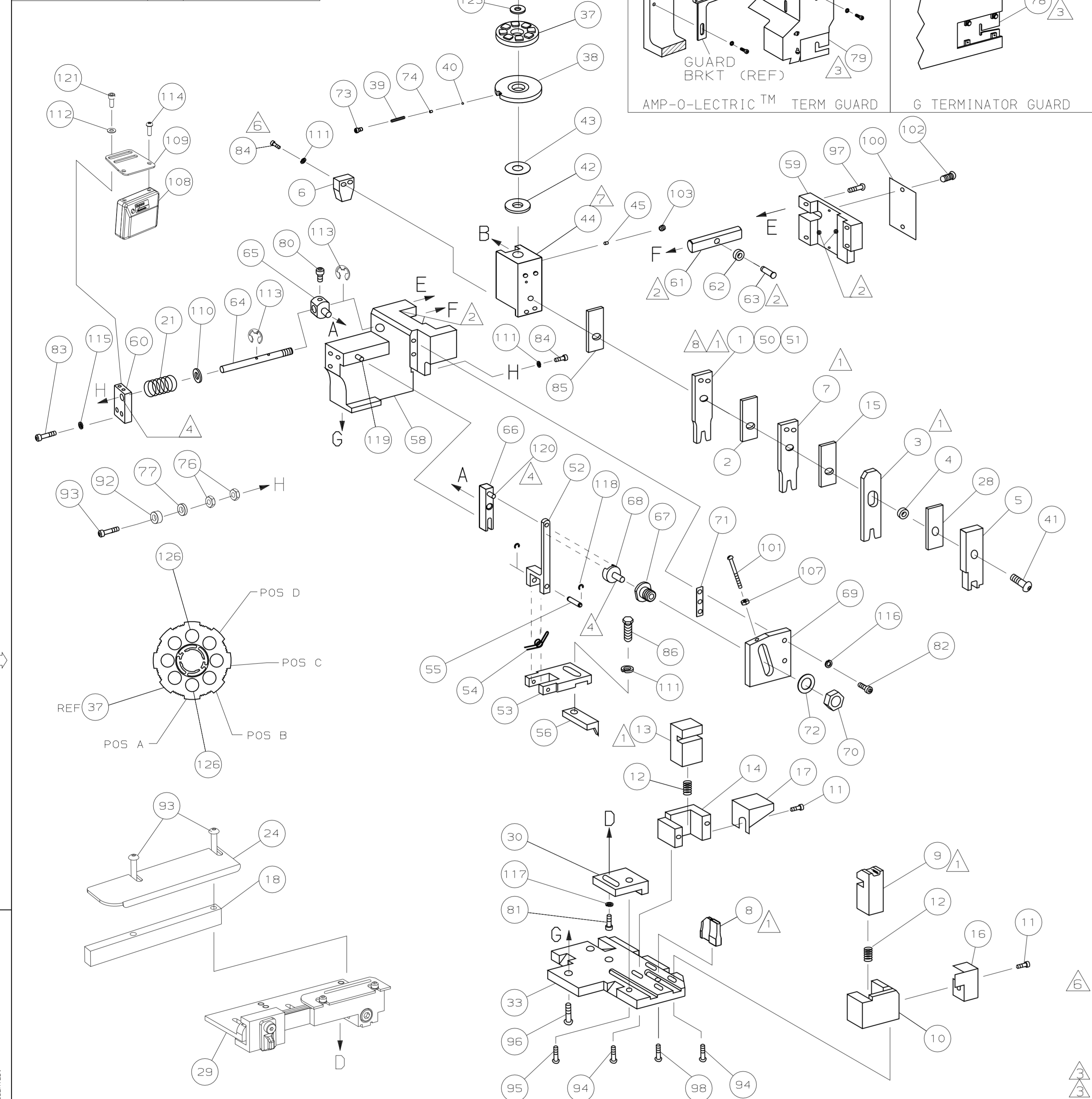

- 1 RECOMMENDED SPARE PARTS.
- 2 GREASE LIGHTLY.
- 3 GUARD MUST BE IN PLACE WHEN OPERATING APPLICATOR IN A BENCH MACHINE.
- 4 LUBRICATE DAILY USING NO. 20 MACHINE OIL.
- 5. ITEMS WITH QTY OF REF SPECIFIED (EXCEPT ITEMS 78 AND 79) ARE USED ON ITEM 46.
- 6 GRIND AT ASSEMBLY
- 7 REMOVE .062 PIN AT ASSEMBLY
- 8 CRIMP HEIGHT TO BE MEASURED OVER CENTER BARREL (STABILIZER). CRIMPERS MUST BE CHANGED TO MATCH WIRE SIZE.

TERMINAL NAME: BOARD IN-CRIMP			
AMP TERM PN	WIRE CRIMPER	MOLEX TERMINAL	AMP CRIMP SPECS
1572705			
		PAD LTR	CRIMP HEIGHT
	1633305-8	A	.029 ±.002 [0.74 ±0.05mm]
	1633305-9	A	.025 ±.002 [0.64 ±0.05mm]
MFR TERM PN	6-1490019-3	A	.023 ±.002 [0.58 ±0.05mm]
		CRIMP	SIZE
		WIRE	.042 [1.07mm]
		INSUL	.070 [1.78mm]
		TYPE	F
		RANGE	22-26
			.060 MAX
WIRE STRIP LENGTH	TERM APPL SPEC	FEED	APPL INSTRUCTION
.095-.110	NONE	.200	408-8040
			SET UP GAGE LAYOUT
			458637-1 1852048

QTY	REF	REF	REF	REF	REF	DESCRIPTION	ITEM NO
							129
							128
							127
2	2	2	-	C	6-354779-4	PIN, WIRE DISC (.3310)A	126
1	1	1	-	A	986950-1	WASHER, FLAT PRECISION	125
1	1	1	-	A	217238-1	GENERAL INSTRUCTION PACKAGE	124
1	1	1	-	-	4088040	SF APPL INST 408-8040	123
							122
REF	REF	REF	-	A	9-21000-9	SCR, SKT HD CAP 8-32 X .438	121
REF	REF	REF	-	A	1-21030-1	PIN, DOWEL (Ø.187x.50) LEVER	120
REF	REF	REF	-	A	1-21030-6	PIN, DOWEL (Ø.187x1.25) HOUSING	119
REF	REF	REF	-	A	21045-3	RING, RET "C" (Ø.187) FD FING PIN	118
1	1	1	-	A	21024-5	WASHER, LOCK (#10) ADJ BLK	117
REF	REF	REF	-	A	21024-5	WASHER, LOCK (#10) ADJ PLATE	116
REF	REF	REF	-	A	21024-5	WASHER, LOCK (#10) ADJ GDE ROD	115
REF	REF	REF	-	A	99499-1	SCREW, OVL HD. M4X12	114
REF	REF	REF	-	A	1-21046-6	RING, RETAIN EXT. E-RING	113
REF	REF	REF	-	A	18028-2	WASHER FLAT REG. M4	112
4	4	4	-	A	21024-4	WASHER, LOCK (#8) STRIPPER	111
REF	REF	REF	-	A	21899-4	WASHER, FLAT (Ø5/16) SCREW ADJ	110
REF	REF	REF	-	A	1804303-1	BRACKET, COUNTER MOUNTING	109
REF	REF	REF	-	A	1804300-1	ASSEMBLY, COUNTER	108
REF	REF	REF	-	A	21068-5	NUT, HEX (6-32) FEED ADJ	107
							106
							105
							104
1	1	1	-	A	21009-2	SCR, SKT SET (1/4-20x.25 LW) RAM	103
2	2	2	-	A	21017-2	SCR, DRIVE (#2x.19) ID PLATE	102
REF	REF	REF	-	A	6-23715-5	SCR, PAN HD (6-32x1.50) FEED ADJ	101
1	1	1	-	B	461264-1	PLATE, IDENTIFICATION	100
							99
1	1	1	-	A	22733-8	SCR, BHC (8-32x.38 LW) ANVIL	98
REF	REF	REF	-	A	2-21002-9	SCR, BHC (10-32x.75) CAP	97
REF	REF	REF	-	A	2-22733-8	SCR, BHC (1/4-20x.62) HOUSING	96
REF	REF	REF	-	A	2-21002-7	SCR, BHC (10-32x.50) SG ADJ BLOCK	95
2	2	2	-	A	2-21002-2	SCR, BHC (8-32x.50) TERM H DWN	94
2	2	2	-	A	2-21002-4	SCR, BHC (8-32x.750) R STP GDE	93
							92
1	1	1	-	A	1-21002-7	SCR, BHC (6-32x.38) CAM	91
							90
							89
							88
							87
1	1	1	-	A	2-22603-0	SCR, HEX HD (8-32x.31) FEED FINGER	86
1	1	1	-	C	1-455888-2	SPACER, CRIMPER	85
3	3	3	-	A	2-21000-7	SCR, SHC (8-32x.50) STRIPPER	84
REF	REF	REF	-	A	3-21000-7	SCR, SHC (10-32x.75) FEED ROD 6D	83
REF	REF	REF	-	A	3-21000-6	SCR, SHC (10-32x.62) FD ADJ BLK	82
1	1	1	-	A	3-21000-4	SCR, SHC (10-32x.38) SG ADJ BL	81
REF	REF	REF	-	A	3-21000-4	SCR, SHC (10-32x.38) PIVOT BLK	80
-	REF	-	-	B	455749-1	GUARD, WINDOW	79
REF	-	-	-	B	679532-1	INSERT, GUARD	78
							77
							76
							75
1	1	1	-	A	690603-1	SPRING, ASSIST	74
1	1	1	-	A	23030-1	SCR, SHC (6-32x.25 SL) INS DISC	73
REF	REF	REF	-	A	458109-1	WASHER, SPECIAL	72
REF	REF	REF	-	A	690517-1	SPACER	71
							70
							69
							68
							67
							66
							65
							64
							63
							62
							61
							60
							59
							58
							57
							56
							55
							54
							53
							52
							51
							50
							49
							48
							47
							46
							45
							44
							43
							42
							41
							40
							39
							38
							37
							36
							35
							34
							33
							32
							31
							30
							29
							28
							27
							26
							25
							24
							23
							22
							21
							20
							19
							18
							17
							16
							15
							14
							13
							12
							11
							10
							9
							8
							7
							6
							5
							4
							3
							2
							1

QTY	REF	REF	REF	REF	REF	DESCRIPTION	ITEM NO
							129
							128
							127
							126
							125
							124
							123
							122
							121
							120
							119
							118
							117
							116
							115
							114
							113
							112
							111
							110
							109
							108
							107
							106
							105
							104
							103
							102
							101
							100
							99
							98
							97
							96
							95
							94
							93
							92
							91
							90
							89
							88
							87
							86
							85
							84
							83
							82
							81
							80
							79
							78
							77
							76
							75
							74
							73
							72
							71
							70
							69
							68
							67
							66
							65
							64
							63
							62
							61
							60
							59
							58
							57
							56
							55
							54
							53
							52
							51
							50
							49
							48
							47
							46
							45
							44
							43
							42
							41
							40
							39
							38
							37
							36
							35
							34
							33
							32
							31
							30

# Mouser Electronics

Authorized Distributor

Click to View Pricing, Inventory, Delivery & Lifecycle Information:

[TE Connectivity:](#)

[1852048-2](#)