

THIS DRAWING IS UNPUBLISHED. RELEASED FOR PUBLICATION
 © COPYRIGHT - By - ALL RIGHTS RESERVED.

LOC		DIST		REVISIONS			
P	LTR	DESCRIPTION	DATE	DWN	APVD		
	T1	REVISED PER ECO-11-005139	21MAR11	RK	HMR		

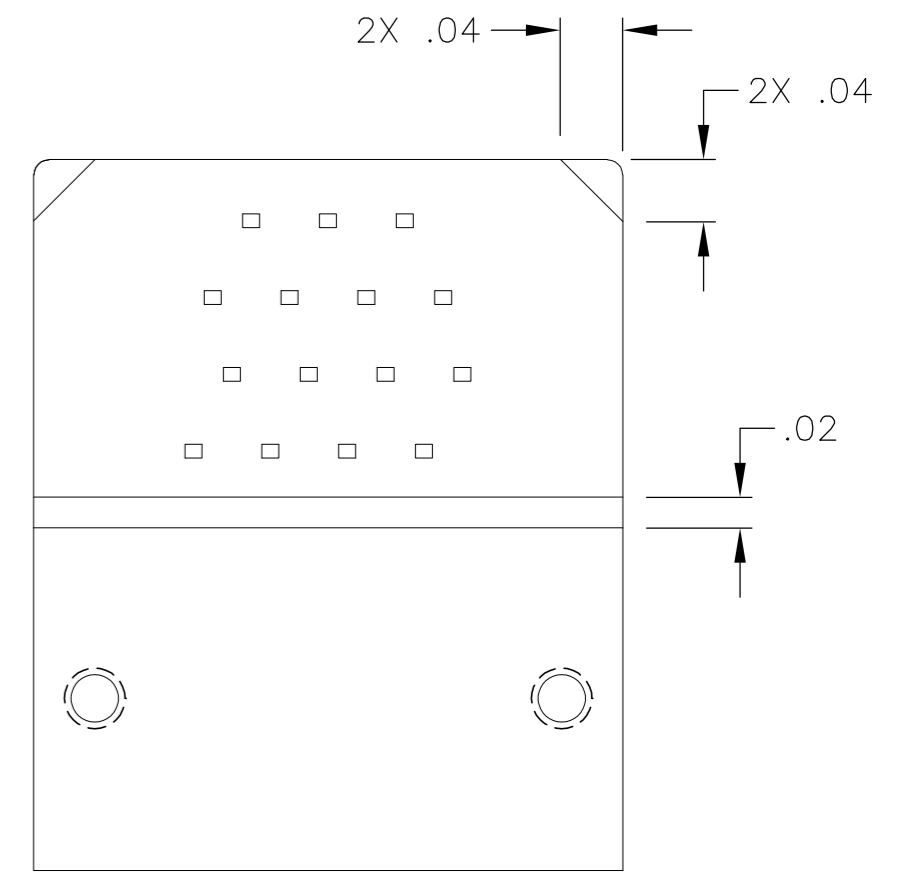
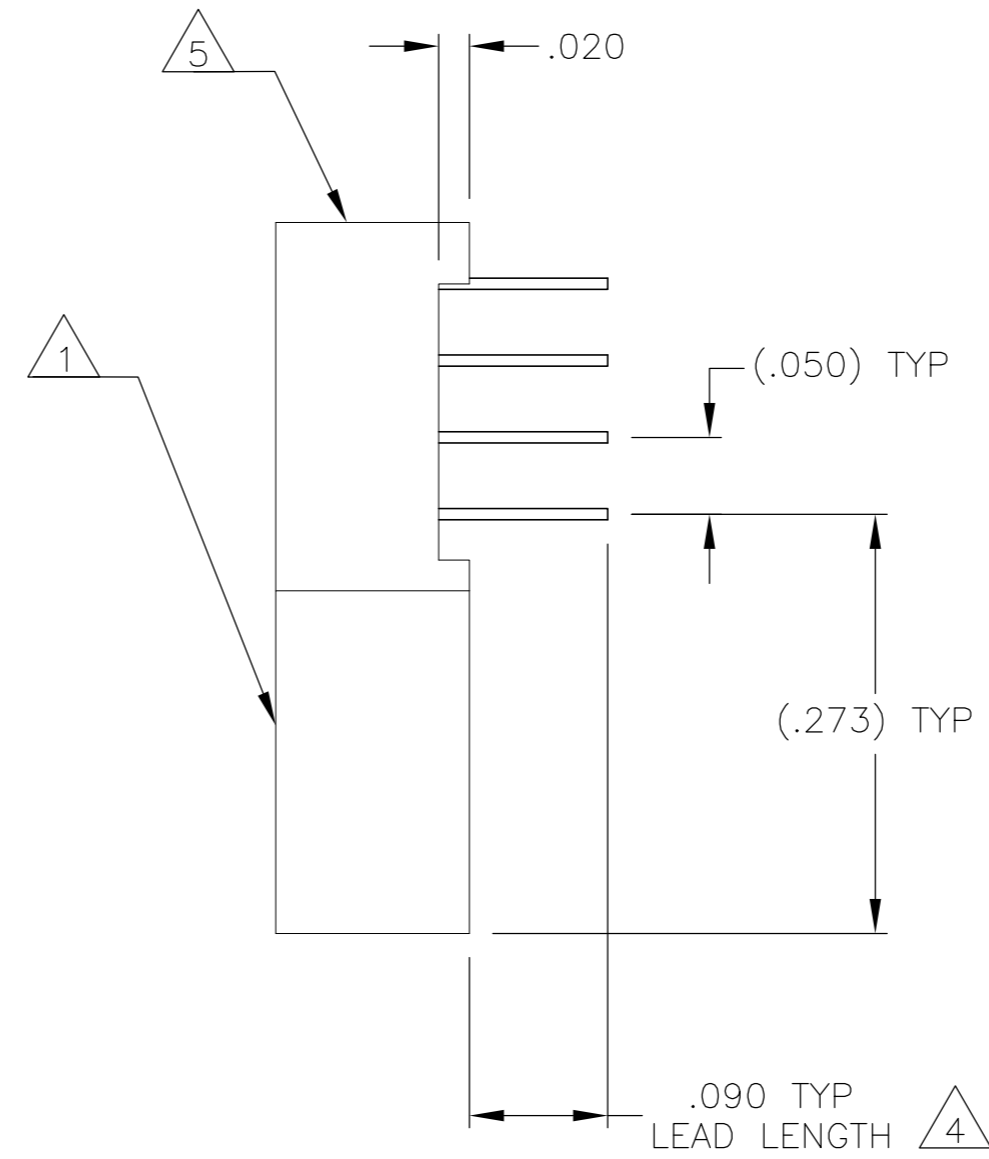
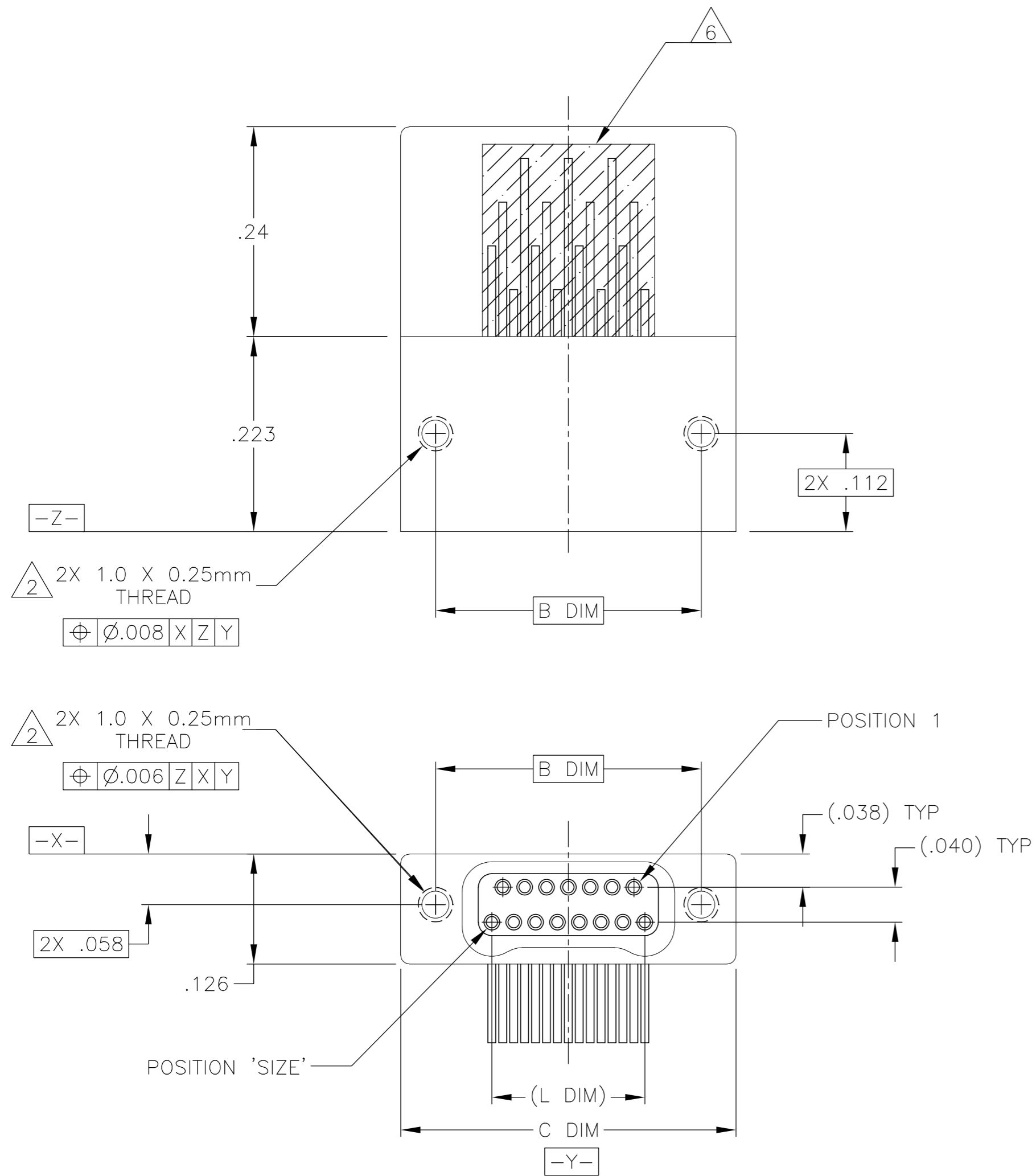

SIZE	B DIM	C DIM ±.0050	(L DIM)
09	.229	.3085	(.100)
15	.304	.3835	(.175)
25	.429	.5085	(.300)
37	.579	.6585	(.450)
51	.754	.8335	(.625)
65	.929	1.0085	(.800)

- 1. SHELL OPTIONS (TO BE SPECIFIED IN NANONICS PART NUMBER):
 METAL: 6061-T6 ALUMINUM, ELECTROLESS NICKEL PLATED PER SAE-AMS-C-26074 (STANDARD) OR GOLD PLATED PER ASTM B488
 303 STAINLESS STEEL, PASSIVATED PER SAE-AMS-2700
 INSULATOR MATERIAL FOR ALL METAL SHELLS IS LIQUID CRYSTAL POLYMER (LCP) PER MIL-M-24519 OR PER ASTM D5138
 PLASTIC: LIQUID CRYSTAL POLYMER (LCP) PER MIL-M-24519 OR PER ASTM D5138
- 2. STANDARD 1.0 X 0.25mm MOUNTING AND JACKSCREW THREADS ARE SHOWN FOR REFERENCE ONLY AND MUST BE SPECIFIED IN THE NANONICS PART NUMBER WHEN REQUIRED. 1.2 X 0.25mm THREADS ALSO AVAILABLE.
- 3. MOUNTING HARDWARE IS AVAILABLE WITH THIS CONFIGURATION (NOT SHOWN). HARDWARE MUST BE SPECIFIED IN THE NANONICS PART NUMBER. CONSULT TE CONNECTIVITY FOR DETAILS.
- 4. LEADS ARE HH BRASS, TIN LEAD PLATED 60/40 COMPOSITION PER SAE-AMS-P-81728.
- 5. LEAD ORGANIZER MATERIAL IS LIQUID CRYSTAL POLYMER PER ASTM D5138.
- 6. THROUGH HOLE LEADS ARE EPOXY ENCAPSULATED WITHIN THE LEAD ORGANIZER.
- 7. TERMINATION CODE: M6
- 8. THIS DRAWING PREVIOUSLY IDENTIFIED AS NANONICS N10138/250

THIS DRAWING IS A CONTROLLED DOCUMENT.		DWN D. RYAN 15 JUN 00	 TE Connectivity	NAME		
DIMENSIONS: INCHES		CHK M. STORRY 15 JUN 00		RECEPTACLE ASSEMBLY, HORIZONTAL MOUNT, THROUGH HOLE, 2 TO 4 ROW, .050 SPACING, PLASTIC OR METAL		
TOLERANCES UNLESS OTHERWISE SPECIFIED: 0 PLC ± - 1 PLC ± - 2 PLC ± .010 3 PLC ± .005 4 PLC ± - ANGLES ± 1°		APVD S. KAIN 15 JUN 00		SIZE	CAGE CODE	DRAWING NO
MATERIAL SEE NOTES		FINISH SEE NOTES		A2	OPJN9	C=1589487
CUSTOMER DRAWING		WEIGHT -	SCALE 8:1	SHEET 1 of 2	REV T1	

THIS DRAWING IS UNPUBLISHED. RELEASED FOR PUBLICATION
 © COPYRIGHT - By - ALL RIGHTS RESERVED.

LOC		DIST		REVISIONS			
P	LTR	DESCRIPTION	DATE	DWN	APVD		
-	-	SEE SHEET 1	-	-	-		

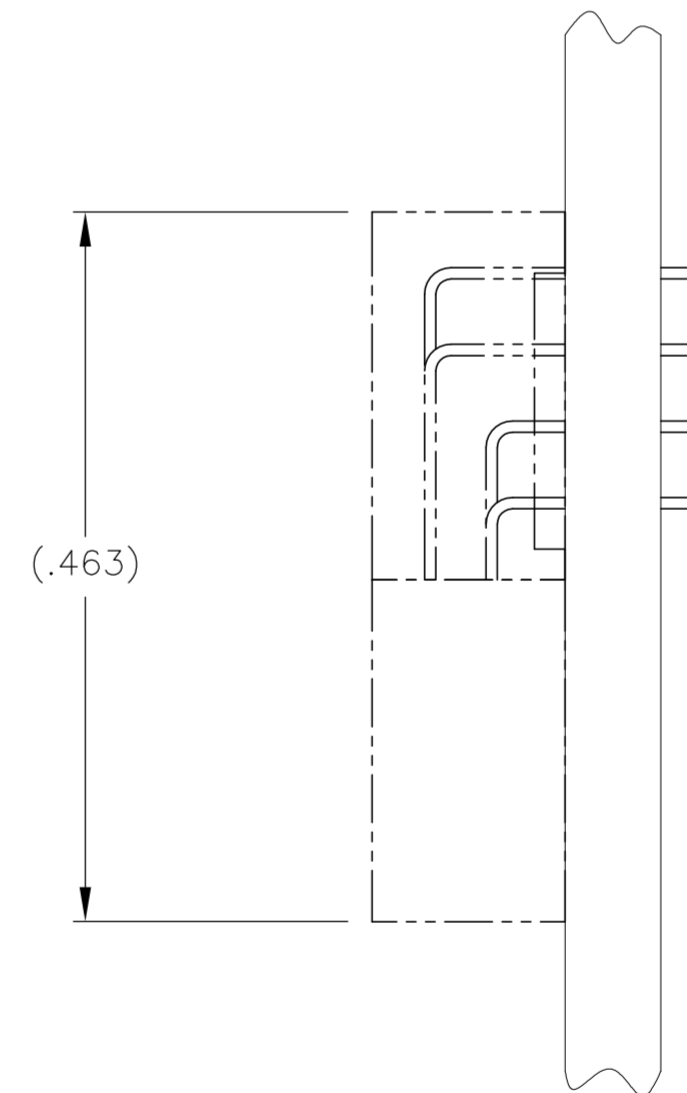
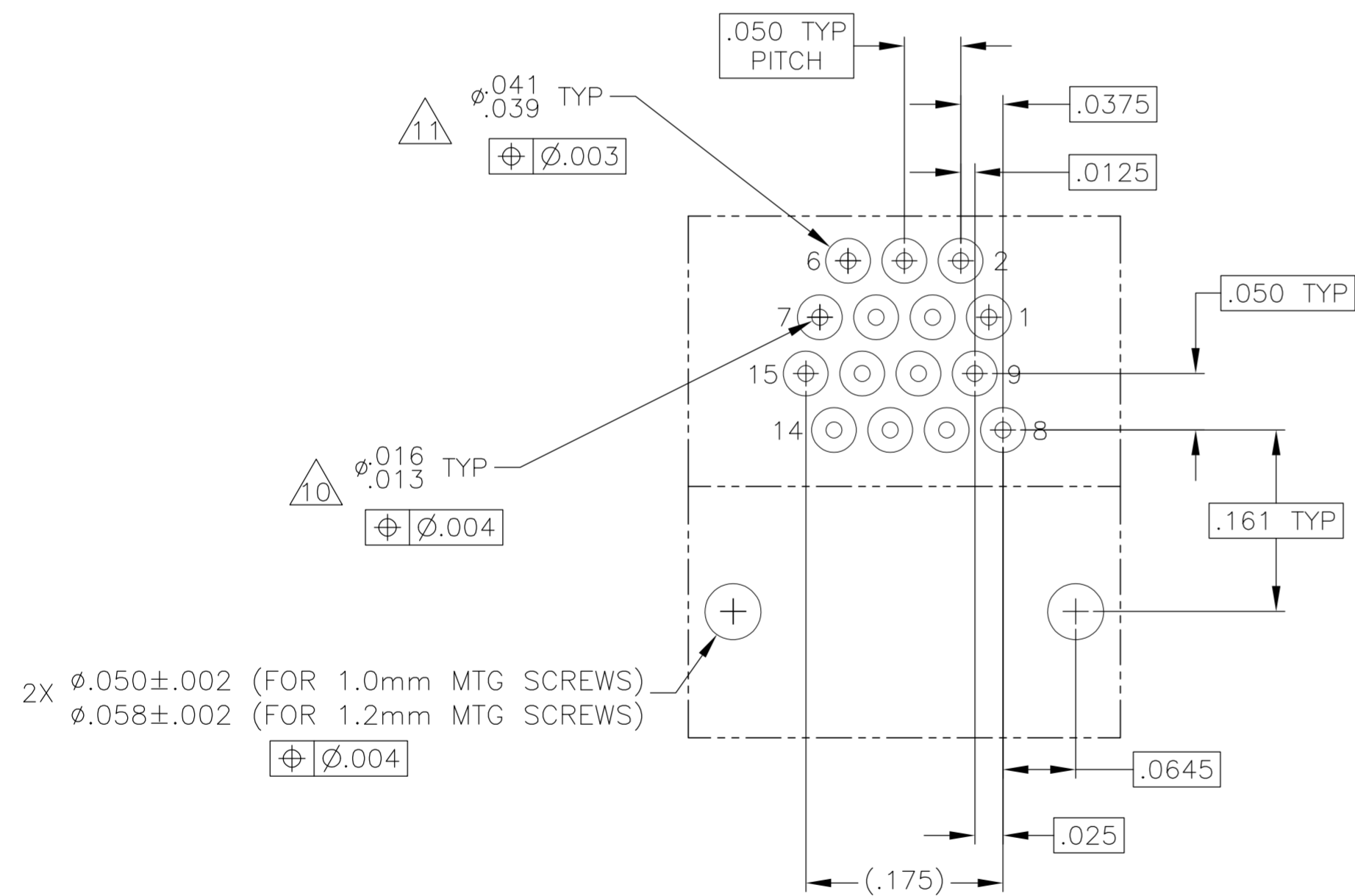
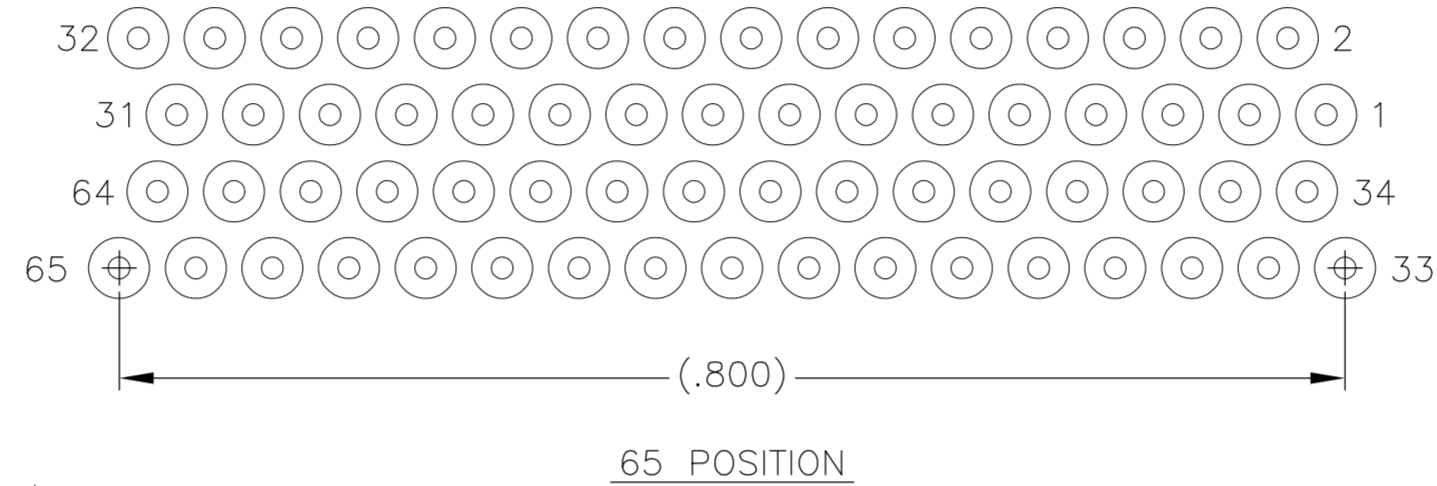
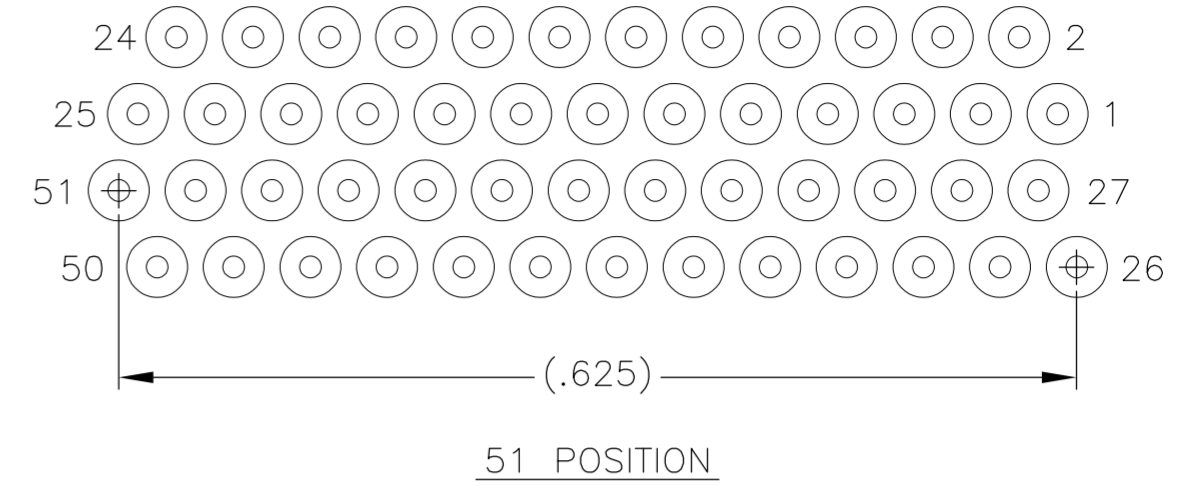
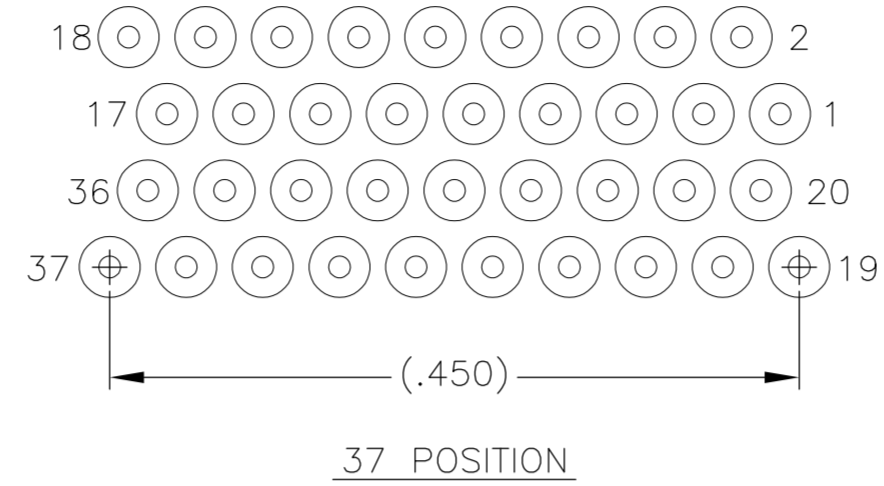
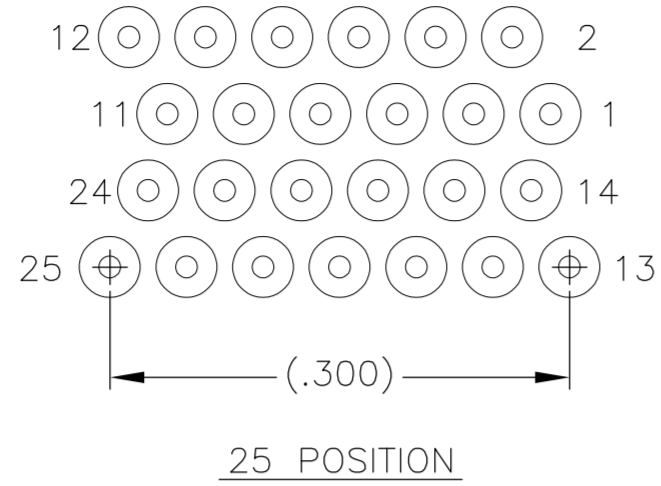
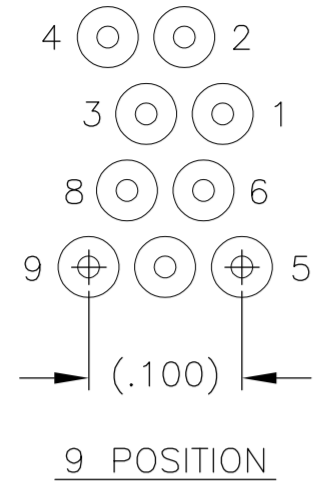

- $\triangle 9$. POSITIONAL TOLERANCES FOR BASIC DIMENSIONED FEATURES ARE RELATIVE TO FIDUCIALS OR SOME SIMILAR DATUM REFERENCES DEFINED BY PCB DESIGNER.
- $\triangle 10$. PLATED THROUGH HOLES
- $\triangle 11$. SOLDER PADS
- 12. ALL THROUGH HOLE LAYOUTS ARE AS VIEWED FROM TOP OF PCB.

THIS DRAWING IS A CONTROLLED DOCUMENT.		DWN D. RYAN 15 JUN 00	TE Connectivity																									
DIMENSIONS: INCHES		CHK M. STORRY 15 JUN 00																										
TOLERANCES UNLESS OTHERWISE SPECIFIED:		APVD S. KAIN 15 JUN 00	NAME RECEPTACLE ASSEMBLY, HORIZONTAL MOUNT, THROUGH HOLE, 2 TO 4 ROW, .050 SPACING, PLASTIC OR METAL																									
<table border="1"> <tr><td>0</td><td>PLC</td><td>±</td><td>-</td></tr> <tr><td>1</td><td>PLC</td><td>±</td><td>-</td></tr> <tr><td>2</td><td>PLC</td><td>±</td><td>.010</td></tr> <tr><td>3</td><td>PLC</td><td>±</td><td>.005</td></tr> <tr><td>4</td><td>PLC</td><td>±</td><td>-</td></tr> <tr><td colspan="2">ANGLES</td><td colspan="2">± 1°</td></tr> </table>		0	PLC	±	-	1	PLC	±	-	2	PLC	±	.010	3	PLC	±	.005	4	PLC	±	-	ANGLES		± 1°		PRODUCT SPEC -	SIZE A2	CAGE CODE 0PJN9
0	PLC	±	-																									
1	PLC	±	-																									
2	PLC	±	.010																									
3	PLC	±	.005																									
4	PLC	±	-																									
ANGLES		± 1°																										
MATERIAL SEE NOTES		FINISH SEE NOTES	WEIGHT -	DRAWING NO C=1589487																								
CUSTOMER DRAWING			SCALE 8:1	SHEET 2 of 2																								
			RESTRICTED TO -	REV T1																								

Mouser Electronics

Authorized Distributor

Click to View Pricing, Inventory, Delivery & Lifecycle Information:

[TE Connectivity:](#)

[STM037M6AN](#)