

REVISONS		DATE	BY	APPV
LOC	DIST			
B	REV PER ECO-11-022285	10NOV11	PY	RL

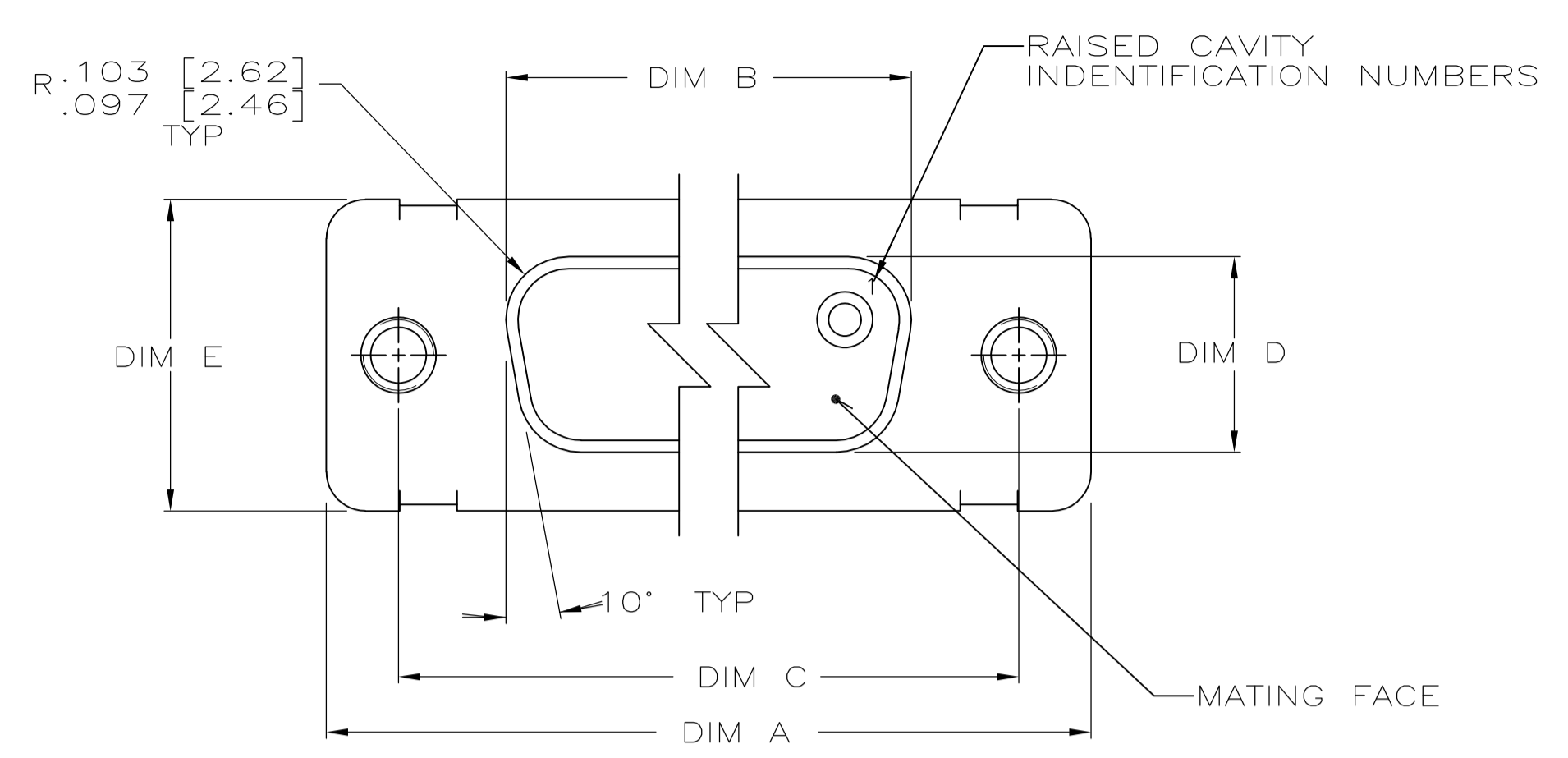

- THE CONNECTORS DESCRIBED IN THIS DOCUMENT WILL MATE WITH ANY PLUG CONNECTOR WITH THE SAME INSERT ARRANGEMENT.
- MARKED WITH .047 [1.19]-.062 [1.57] HIGH CHARACTERS. FAR SIDE REFERS TO THE WIDE SIDE OF THE KEYSTONE. NEAR SIDE REFERS TO THE NARROW SIDE OF THE KEYSTONE. IF THE FRONT SHELL IS TOO SMALL FOR "AMP", AMP PART NUMBER AND DATE CODE, THEN SPLIT AS FOLLOWS:
 - AMP PART NUMBER ON REAR SHELL, NEAR SIDE.
 - "AMP" AND DATE CODE ON FRONT SHELL, NEAR SIDE.

MARK AMP, AMP PART NO AND DATE CODE, FAR SIDE.

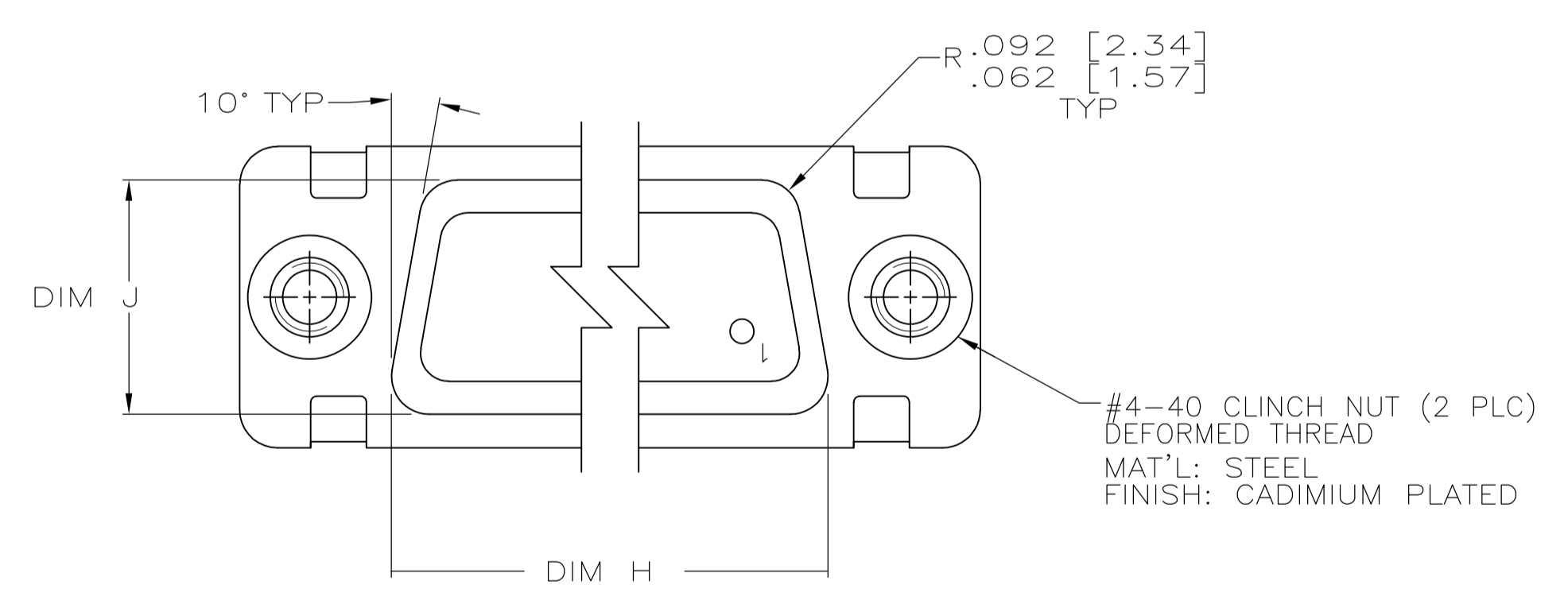
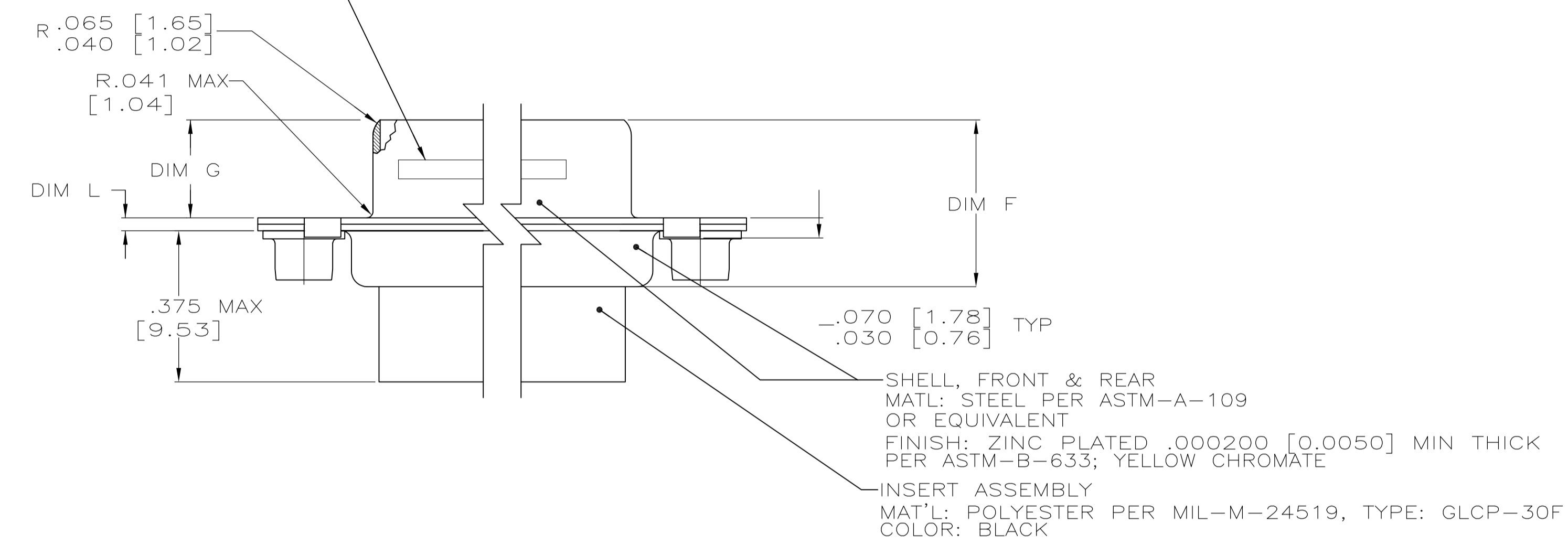

.049 [1.24]	.606 [15.39]	2.312 [58.72]	.248 [6.30]	.439 [11.15]	.683 [17.35]	.490 [12.45]	2.505 [63.63]	2.194 [55.73]	2.744 [69.70]	MS14004-1	104	6	1218747-6
.029 [0.74]	.586 [14.88]	2.292 [58.22]	.238 [6.05]	.419 [10.64]	.653 [16.59]	.480 [12.19]	2.495 [63.37]	2.184 [55.47]	2.714 [68.94]	MS18277-2	78	5	1218747-5
.040 [1.02]	.544 [13.82]	2.188 [55.58]	.248 [6.30]	.439 [11.15]	.620 [15.75]	.428 [10.87]	2.411 [61.24]	2.069 [52.55]	2.650 [67.31]	MS18276-2	62	4	1218747-4
.020 [0.51]	.524 [13.31]	2.168 [55.07]	.238 [6.05]	.419 [10.64]	.590 [14.99]	.418 [10.62]	2.401 [60.99]	2.059 [52.30]	2.620 [66.55]	MS18275-2	44	3	1218747-3
.049 [1.24]	.432 [10.97]	1.635 [41.53]	.248 [6.30]	.439 [11.15]	.509 [12.93]	.316 [8.03]	1.857 [47.17]	1.516 [38.51]	2.103 [53.42]	MS18274-2	26	2	1218747-2
.029 [0.74]	.412 [10.46]	1.615 [41.02]	.238 [6.05]	.419 [10.64]	.479 [12.17]	.306 [7.77]	1.847 [46.91]	1.506 [38.25]	2.073 [52.65]	MS18273-2	15	1	1218747-1
.040 [1.02]	.432 [10.97]	1.093 [27.76]	.248 [6.30]	.439 [11.15]	.509 [12.93]	.316 [8.03]	1.317 [33.45]	.976 [24.79]	1.556 [39.52]				
.020 [0.51]	.412 [10.46]	1.073 [27.25]	.238 [6.05]	.419 [10.64]	.479 [12.17]	.306 [7.77]	1.307 [33.20]	.966 [24.54]	1.526 [38.76]				
.040 [1.02]	.432 [10.97]	.769 [19.53]	.248 [6.30]	.439 [11.15]	.509 [12.93]	.316 [8.03]	.989 [25.12]	.648 [16.46]	1.228 [31.19]				
.020 [0.51]	.412 [10.46]	.749 [19.02]	.238 [6.05]	.419 [10.64]	.479 [12.17]	.306 [7.77]	.979 [24.87]	.638 [16.21]	1.198 [30.43]				
L	J	H	G	F	E	D	C	B	A	INSERT ARRANGEMENT	NO OF POS	SHELL SIZE	PART NUMBER

THIS DRAWING IS A CONTROLLED DOCUMENT.

DIMENSIONS: INCHES. TOLERANCES UNLESS OTHERWISE SPECIFIED:

0 PLC	± .005
1 PLC	± .004
2 PLC	± .003
3 PLC	± .002
4 PLC	± .001
ANGLES	± .001

MATERIAL: - FINISH: -

WEIGHT: -

CUSTOMER DRAWING

DIN: C.C. THOMAS 11-13-00
CHK: R. GROSS 11-13-00
APPV: R. GROSS 11-13-00
NAME: RECEPTACLE ASSY, AMPLIMITE, SERIES 90 SIZE 22, ZINC PLATED WITH #4-40 CLINCH NUTS

SIZE: A1 CAGE CODE: 00779 DRAWING NO: 1218747 RESTRICTED TO: -

SCALE: 1:1 SHEET: 1 OF 1 REV: B

Mouser Electronics

Authorized Distributor

Click to View Pricing, Inventory, Delivery & Lifecycle Information:

[TE Connectivity:](#)

[1218747-6](#)