

Proper use guidelines

Cumulative trauma disorders can result from the prolonged use of manually powered hand tools. Hand tools are intended for occasional use and low-volume applications. A wide selection of powered application equipment is available for extended-use production operations. The PRO--CRIMPER III Hand Crimping Tool is a commercial-grade tool. Product crimped with this tool meets the wire barrel crimp height requirement for hand tools in the appropriate 114 application specification but might not comply with other feature parameters of the specification.

Figure 1: PRO- CRIMPER* III Hand Tool Assembly 58529-1 with Die Assembly 58529-2

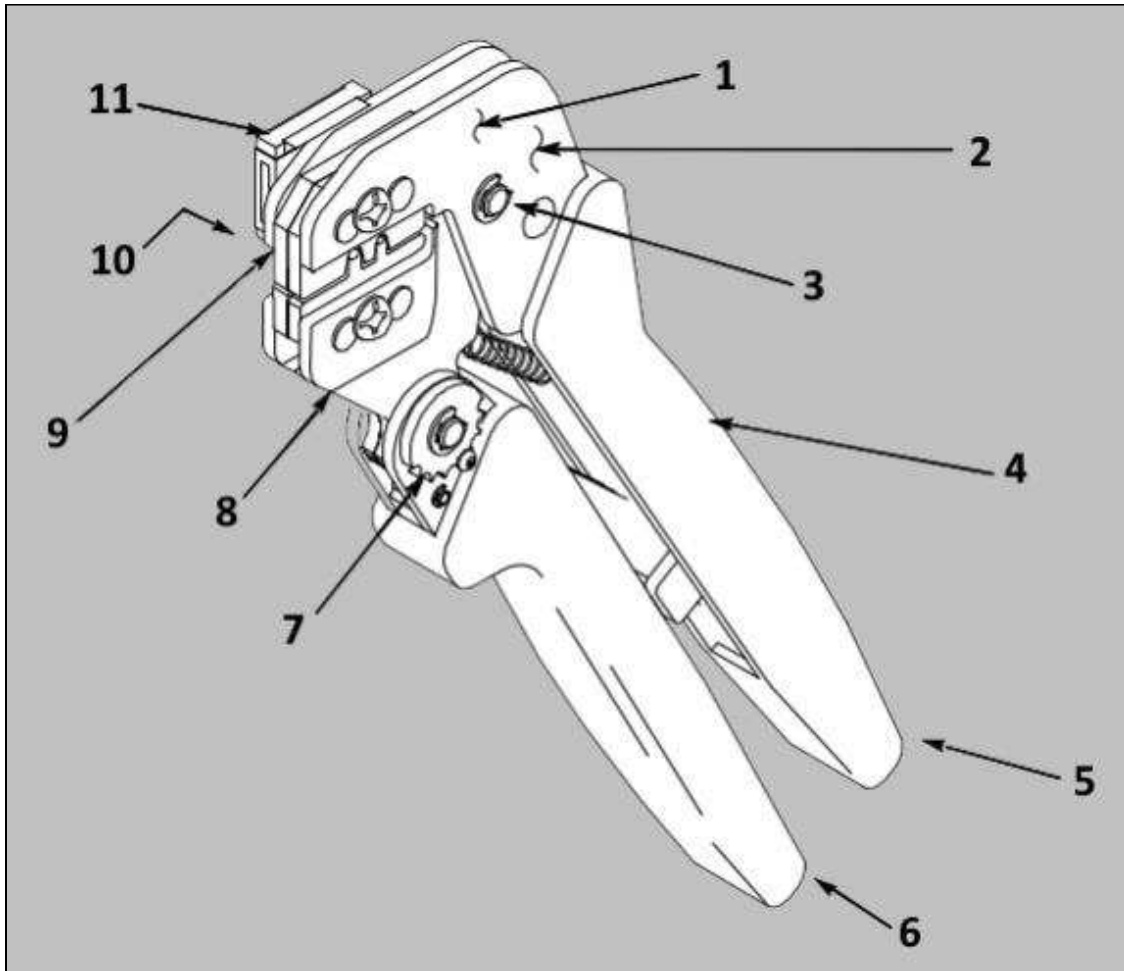

- | | |
|---|---------------------------------|
| 1 Stationary Jaw | 6 Moving Handle |
| 2 Back of Tool (Wire Side) | 7 Ratchet Adjustment Wheel |
| 3 Pivot Pin | 8 Moving Jaw |
| 4 PRO-CRIMPER III Hand Crimping Tool Frame 354940-1 | 9 Die Assembly |
| 5 Stationary Handle | 10 Front of Tool (Locator Side) |
| 11 Locator Assembly (Supplied with Die Assembly) | |

1 Introduction

PRO-CRIMPER III Hand Crimping Tool Assembly 58529-1 consists of Die Assembly 58529-2 and PRO-CRIMPER III Hand Tool Frame 354940-1 (instruction sheet [408-9930](#)). The die assembly consists of crimping dies and a locator assembly. Reasons for reissue are provided in Section 10, **Revision summary**.

Table 1: Crimping specifications

TE Die assembly	TE Locator assembly†	Contact Family‡	Wire		
			Wire size [AWG]	Insulation Diameter	Strip Length mm [In.]
58529-2	58515-1	AMPSEAL Contacts	16	1.7 to 2.7 [.07 to .11]	5.15 ±.4 [.20 ± .02]
			18-20		

† Supplied with the die assembly. Also available separately.

‡ Call the Tooling Assistance Center or Production Information (see below) for product part numbers.



NOTE

Dimensions in this instruction sheet are in millimeters with [inches in brackets]. Figures are for reference only and are not drawn to scale.

Read these instructions thoroughly before crimping connectors.

2 Description (Figure 1 And Figure 2)

The tool features a tool frame with a stationary jaw and handle, a moving jaw, a moving handle, and an adjustable ratchet that ensures full contact crimping. The tool frame holds a die assembly with two crimping sections. The die assembly features a wire anvil, an insulation anvil, a wire crimper, and an insulation crimper.

Attached to the outside of the frame is a locator assembly, which contains a locator, a spring retainer, and a contact support. Die retaining pins and die retaining screws are used to position and secure the dies in the tool frame. A nut is used on the upper die retaining screw to hold the locator assembly in place.



CAUTION

The dies bottom before the ratchet releases. This design feature ensures maximum electrical and tensile performance of the crimp. **Do not** re-adjust the ratchet unless you have verified that the crimp height is incorrect (see section 7 Ratchet adjustment).

Figure 2: PRO-CRIMPER* III Hand Crimping Tool Assembly

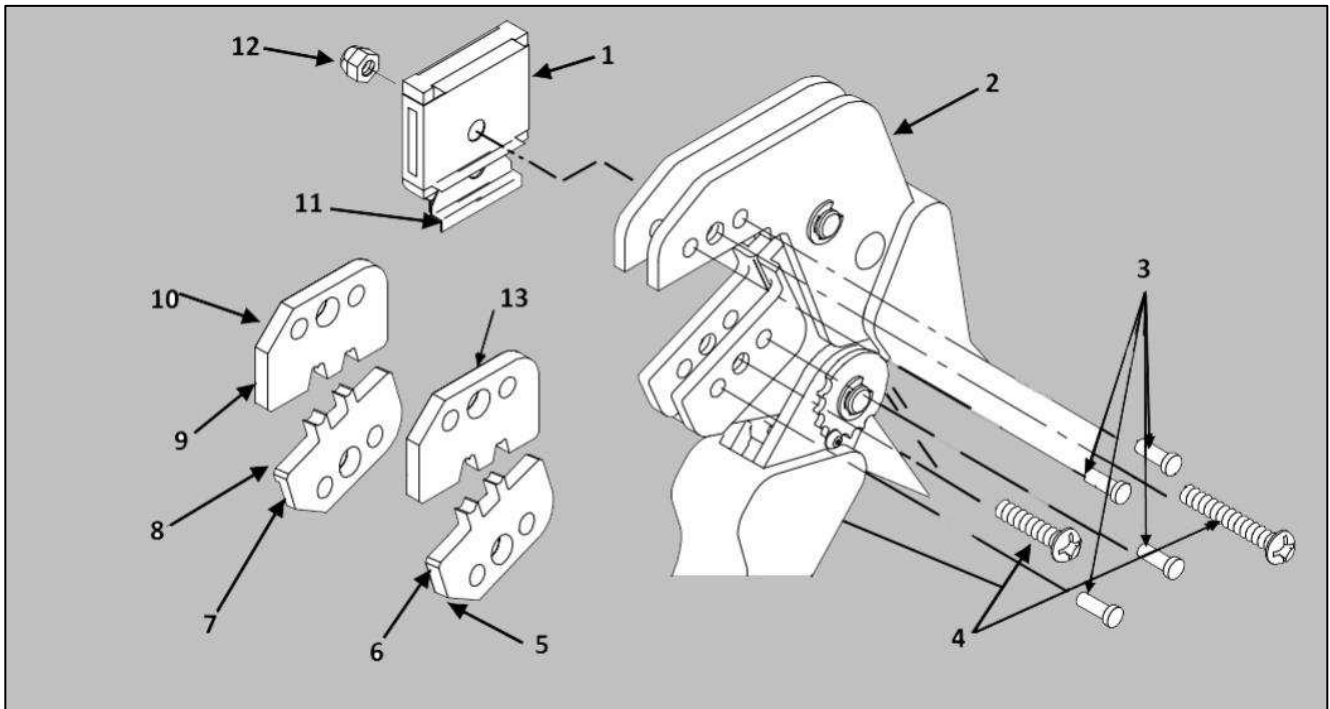

- | | |
|-------------------------------|------------------------------|
| 1 Locator Assembly | 8 Offset |
| 2 Tool Frame | 9 Wire Crimper |
| 3 Die Retaining Pins | 10 Chamfer |
| 4 Die Retaining Screws | 11 Locator |
| 5 Chamfer | 12 Nut |
| 6 Insulation Anvil | 13 Insulation Crimper |
| 7 Wire Anvil | |

3 Installation and removal the die set and locator assembly. (Figure 2)

1. Open the tool handles and remove the two die retaining screws from the tool jaws.
2. Place the wire anvil and insulation anvil so that their chamfered sides and their marked surfaces face outward, when mounted in the moving jaw of the tool frame.
3. Insert the two die retaining pins.
4. Insert the short die retaining screw through the jaw and through both anvil dies then tighten the screw just enough to hold the dies in place. Do not tighten the screw completely at this time.
5. Place the wire crimper and insulation crimper so that their chamfered sides and their marked surfaces face outward, when mounted in the stationary jaw of the tool frame.
6. Insert the two die retaining pins.
7. Insert the long die retaining screw through the jaw and through both crimper dies, then tighten the screw just enough to hold the dies in place. Do not tighten the screw completely at this time.
8. Carefully close the tool handles, making sure that the anvils and crimpers align properly.
9. Continue closing the tool handles until the ratchet in the tool frame has engaged sufficiently to hold the anvils and crimpers in place, then tighten both die retaining screws.
10. Place the locator assembly over the end of the long screw and position the locator assembly against the side of the tool jaw.

11. Place the nut onto the end of the long screw and tighten the nut enough to hold the locator assembly in place, while still allowing the locator to slide up and down.
12. To disassemble, close the tool handles until the ratchet releases, remove the nut, the locator assembly, the two die retaining screws, and the four die retaining pins, and slide the anvils and crimpers out of the tool jaws.

4 Contact support adjustment (Figure 3)

i **NOTE**
The contact support is preset prior to shipment, but minor adjustment may be necessary.

1. Make a sample crimp and determine if the contact is straight, bending upward, or bending downward.
2. If adjustment is required, loosen the screw that holds the contact support onto the locator assembly.

i **NOTE**
The ratchet has detents that create audible clicks as the tool handles are closed.

3. Place a contact with wire into the proper nest and close the tool handles until the ratchet reaches the sixth click, or until the contact support touches the contact.
4. Slightly loosen the nut that holds the locator assembly onto the tool frame.
5. Move the contact support as required to eliminate the bending of the contact.
6. Tighten the nut and close the handles until the ratchet releases.
7. Remove and inspect the contact.
8. Make another sample crimp. If the contact is straight, tighten the contact support screw. If the contact is still being bent during crimping, repeat the adjustment procedure.

Figure 3: Crimping

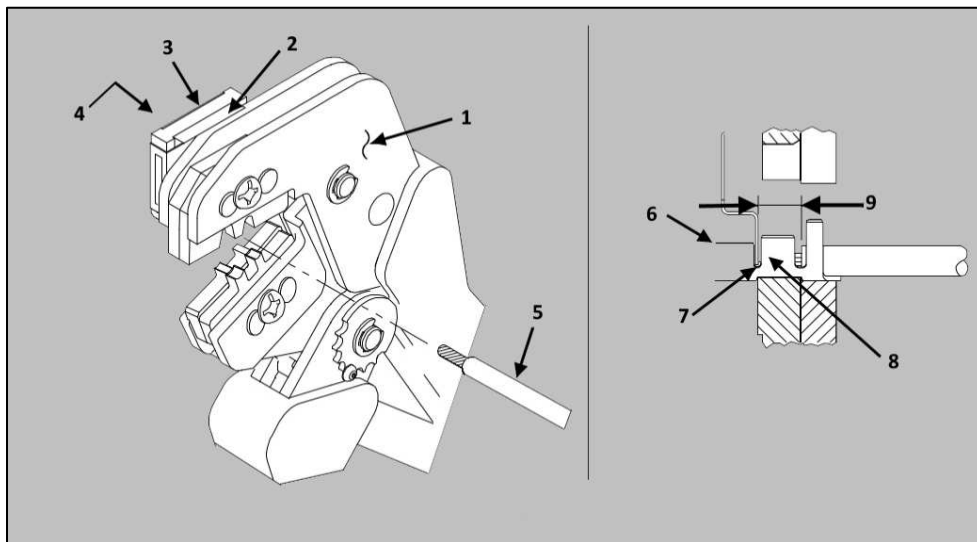

- | | |
|---|--------------------------------|
| 1 Back of Tool (Wire Side) | 6 Contact (Typ) |
| 2 Locator | 7 Locator in Wire Slot |
| 3 Contact Support | 8 Wire Inserted to Stop |
| 4 Adjustment Screw for Contact Support | 9 Strip Length |
| 5 Wire | |

5 Crimping procedure



NOTE

*This tool is provided with a crimp adjustment feature. Initially, the crimp height should be verified as specified in Table 2 Refer to Section 6, **crimp height inspection**, and Section 7, **ratchet adjustment**, to verify crimp height before using the tool to crimp desired contacts and wire sizes.*

Refer Table 1 and select wire of the specified size and insulation diameter. Strip the wire to the length indicated in Table 1, taking care not to nick or cut wire strands. Select an applicable contact and identify the appropriate crimp section according to the wire size markings on the tool. Refer to Table 1 and proceed as follows:

1. Hold the tool so that the back (wire side) is facing you. Squeeze tool handles together and allow them to open fully.
2. Holding the contact by the mating end, insert the contact - insulation barrel first - through the front of the tool and into the appropriate crimp section.
3. Position the contact so that the mating end of the contact is on the locator side of the tool, and so that the open "U" of the wire and insulation barrels face the top of the tool. Place the contact up into the nest so that the movable locator drops into the slot in the contact. refer to Figure 3 Butt the front end of the wire barrel against the movable locator.



CAUTION

Make sure that both sides of the insulation barrel are started evenly into the crimping section. Do not attempt to crimp an improperly positioned contact.

4. Hold the contact in position and squeeze the tool handles together until ratchet engages sufficiently to hold the contact in position. Do not deform insulation barrel or wire barrel.
5. Insert stripped wire into contact insulation and wire barrels until it is butted against the wire stop, as shown in Figure 3.
6. Holding the wire in place, squeeze tool handles together until ratchet releases. Allow tool handles to open and remove crimped contact.



NOTE

The crimped contact may stick in the crimping area, but the contact can be easily removed by pushing downward on the top of the locator (see Figure 3).

7. Check the contact's crimp height as described in Section 6, **crimp height inspection**. If necessary, adjust the crimp height as described in Section 7, **Ratchet adjustment**.

6 Crimp height inspection

Crimp height inspection is performed through the use of a micrometer with a modified anvil, commonly referred to as a crimp-height comparator. TE does not manufacture or market crimp-height comparators. Detailed information on obtaining and using crimp--height comparators can be found in instruction sheet [408-7424](#).

Figure 4: Measuring Crimp Height

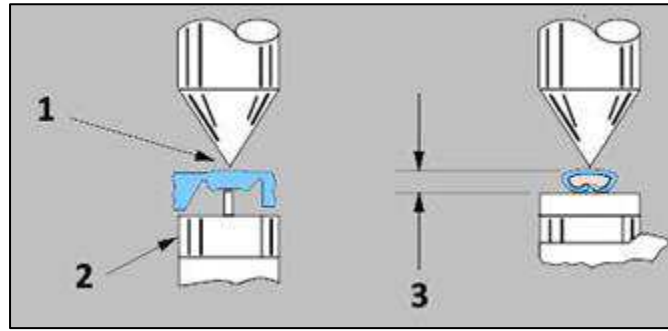

- 1 Position Point on Center of Wire Barrel Opposite Seam
- 2 Modified Anvil
- 3 Dimension "A"

Table 2: Crimp Size

Wire Size AWG (Max)	Crimp Section (Wire Size Marking)	Crimp Height Dimension A
18	20-18	1.22 ±.05 [.048 ±.002]
16	16	1.41 ±.05 [.056 ±.002]

Proceed as follows:

1. Refer to Table 2 and select a wire (maximum size) for each crimp section listed.
2. Refer to Section 5, **Crimping procedure**, and crimp the contact(s) accordingly.
3. Using a crimp height comparator, measure the wire barrel crimp height as shown in Table 2. If the crimp height conforms to that shown in the table, the tool is considered dimensionally correct. If not, the tool must be adjusted. Refer to Section 7, **Ratchet adjustment**.

7 Ratchet adjustment (Crimp Height) (Figure 5)

1. Remove the lockscrew from the ratchet adjustment wheel.
2. With a screwdriver, adjust the ratchet wheel from the locator side of the tool.
3. Observe the ratchet adjustment wheel. If a tighter crimp is required, rotate the adjustment wheel **counterclockwise** to a higher-numbered setting. If a looser crimp is required, rotate the adjustment wheel **clockwise** to a lower-numbered setting.
4. Replace the lockscrew.
5. Make a sample crimp and measure the crimp height. If the dimension is acceptable, replace and secure the lockscrew. If the dimension is unacceptable, continue to adjust the ratchet, and again measure a sample crimp.

Figure 5: Ratchet Adjustment

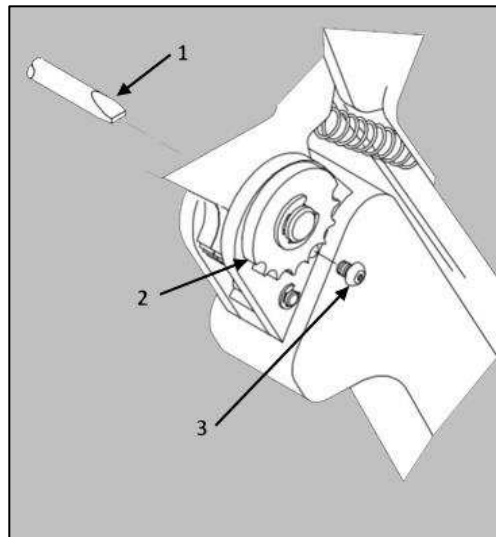

- | | | | |
|---|--------------------------|---|-----------------|
| 1 | Screwdriver | 3 | Lockscrew (Typ) |
| 2 | Ratchet Adjustment Wheel | | |

8 Maintenance and inspection

8.1 Maintenance

- Remove dust, moisture, and other contaminants with a clean, soft brush or soft, lint-free cloth. Do not use objects that could damage the dies or tool.
- When the tool is not in use, keep the handles closed to prevent objects from becoming lodged in the dies.
- Remove all lubrication and accumulated film by immersing the dies in a suitable commercial degreaser.
- Store the tool in a clean, dry area.

8.2 Visual inspection

- Inspect the tool and dies on a regular basis to verify that they are not worn or damaged.
- Make sure that the die retaining screws are properly secured.
- Inspect the crimping chambers of the die assembly for flattened, chipped, worn, or broken areas.
- If damage or abnormal wear is evident, replace the tool or dies. Refer to section 9, **Replacement and repair**.

9 Replacement and repair

If the dies are damaged or worn excessively, they must be replaced. Order replacement dies through your TE representative or go to TE.com and click the **Shop TE Store** link at the top of the web page.

For field service, go to the [Service and Repair](#) page on the TE website, or send an e-mail to the address for your region in Table 3.

Figure 6: Service and repair



Table 3: Field service e-mail addresses

Region	Address
Asia	Tefe1ap@te.com
EMEA (including India)	Tefe1@te.com
North America	Fieldservicesnorthamerica@te.com
South America	FSE@te.com

10 Revision summary

Since the last revision of this document, the following changes were made:

- Document reformatted to latest template.

Mouser Electronics

Authorized Distributor

Click to View Pricing, Inventory, Delivery & Lifecycle Information:

[TE Connectivity:](#)

[58529-1](#) [58529-2](#)