

© 2024 TE Connectivity. All Rights Reserved.

| PART NO   | REV | FIRST USED |
|-----------|-----|------------|
| 2434675-2 | B   | -          |

REVISIONS

| P  | LTR | DESCRIPTION     | DATE        | DWN | APVD |
|----|-----|-----------------|-------------|-----|------|
| B  |     | INITIAL RELEASE | 26 JUN 2024 | RRD | RN   |
| B1 |     | ECR-24-216092   | 26 JUL 2024 | GC  | RN   |
|    |     |                 |             |     |      |
|    |     |                 |             |     |      |

1. RECOMMENDED SPARE PARTS SEE DRAWING 2-2434675-0.
2. IDENTIFY PART PER TEC-115-67-6.
3. TORQUE RECOMMENDATIONS PER 101-35000 UNLESS OTHERWISE SPECIFIED.

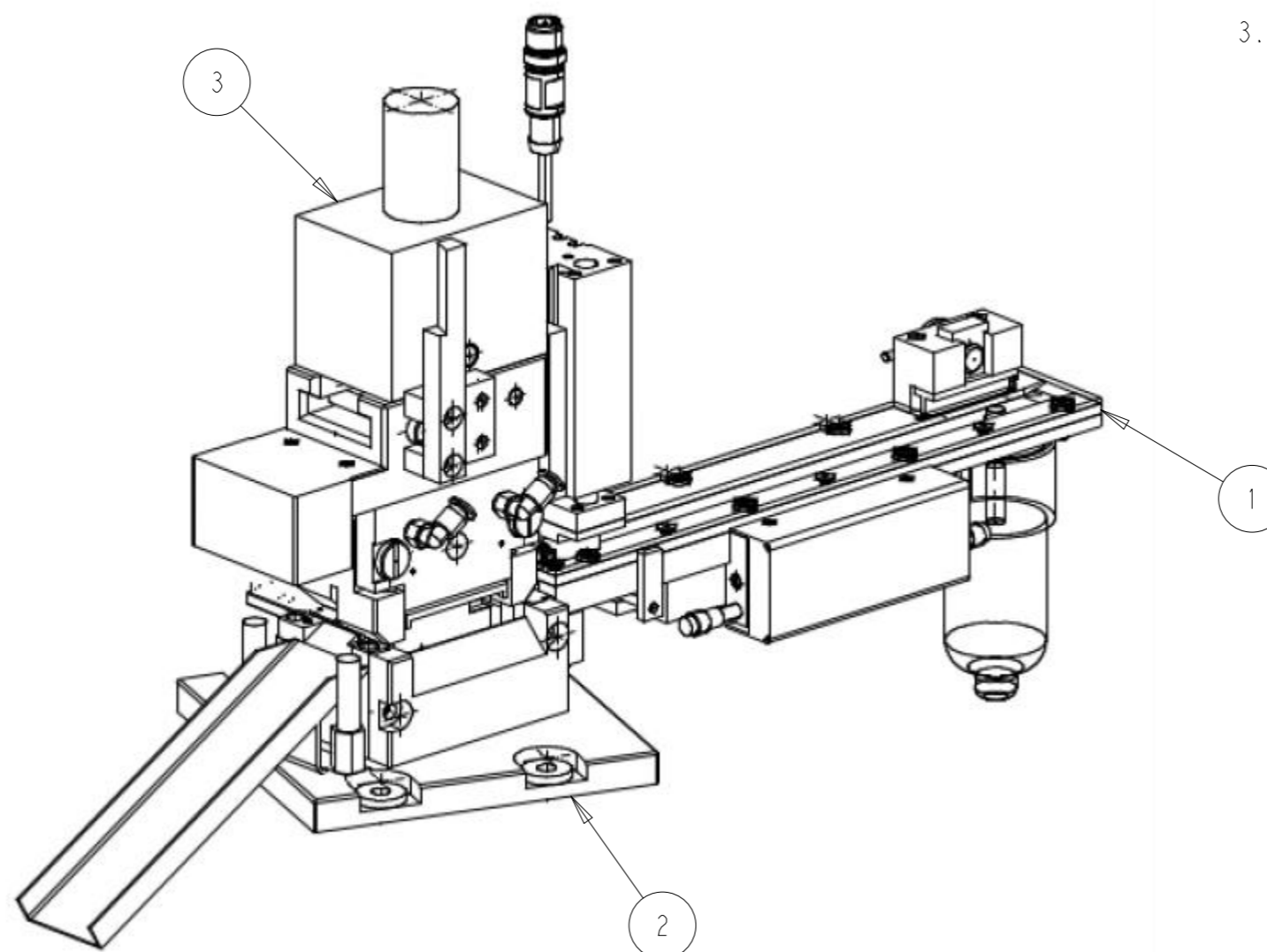

|    |     |            |                 |         |
|----|-----|------------|-----------------|---------|
| 1  | -   | 2475888-2  | TOOL UPPER PART | 3       |
| 1  | -   | 2475888-1  | TOOL LOWER PART | 2       |
| 1  | -   | 3-528420-2 | FEEDING         | 1       |
| -1 | U/M | PART NO    | DESCRIPTION     | ITEM NO |

THIS DRAWING IS A CONTROLLED DOCUMENT.

| DIMENSIONS: |  | TOLERANCES UNLESS OTHERWISE SPECIFIED: |         |
|-------------|--|--|---------|
| mm          |  | 0 PLC                                  | ±       |
|             |  | 1 PLC                                  | ±0.1    |
|             |  | 2 PLC                                  | ±0.01   |
|             |  | 3 PLC                                  | ±0.001  |
|             |  | 4 PLC                                  | ±0.0001 |
| MATERIAL    |  | ANGLES                                 | ±0.30'  |
|             |  | FINISH                                 |         |

|  |           |               |
|--|-----------|---------------|
| DWN                                    | 07MAR2024 | R. DWARAPALAK |
| CHK                                    | 07MAR2024 | R. NITSCHKE   |
| APVD                                   | 07MAR2024 | R. NITSCHKE   |
| PRODUCT SPEC                           | -         |               |
| APPLICATION SPEC                       | -         |               |
| WEIGHT                                 | -         |               |
| CUSTOMER ACCESSIBLE PRODUCTION DRAWING |           |               |



|   |           |             |               |
|---|-----------|-------------|---------------|
| NAME                                    |           |             |               |
| APPLICATOR, FFC F-CRIMP<br>6-8-POSITION |           |             |               |
| SIZE                                    | CAGE CODE | DRAWING NO  | RESTRICTED TO |
| A3                                      | 00779     | ©-2434675-2 | -             |
| SCALE                                   |           | SHEET       | REV           |
| -                                       |           | 1 OF 1      | B1            |

# Mouser Electronics

Authorized Distributor

Click to View Pricing, Inventory, Delivery & Lifecycle Information:

[TE Connectivity:](#)

[2434675-2](#)