

REVISIONS

P	LTR	DESCRIPTION	DATE	DWN	APVD
A		INITIAL RELEASE	10SEP2023	J.S	Z.Z
A1		ECN-24-290823	29OCT2024	J.S	Z.Z

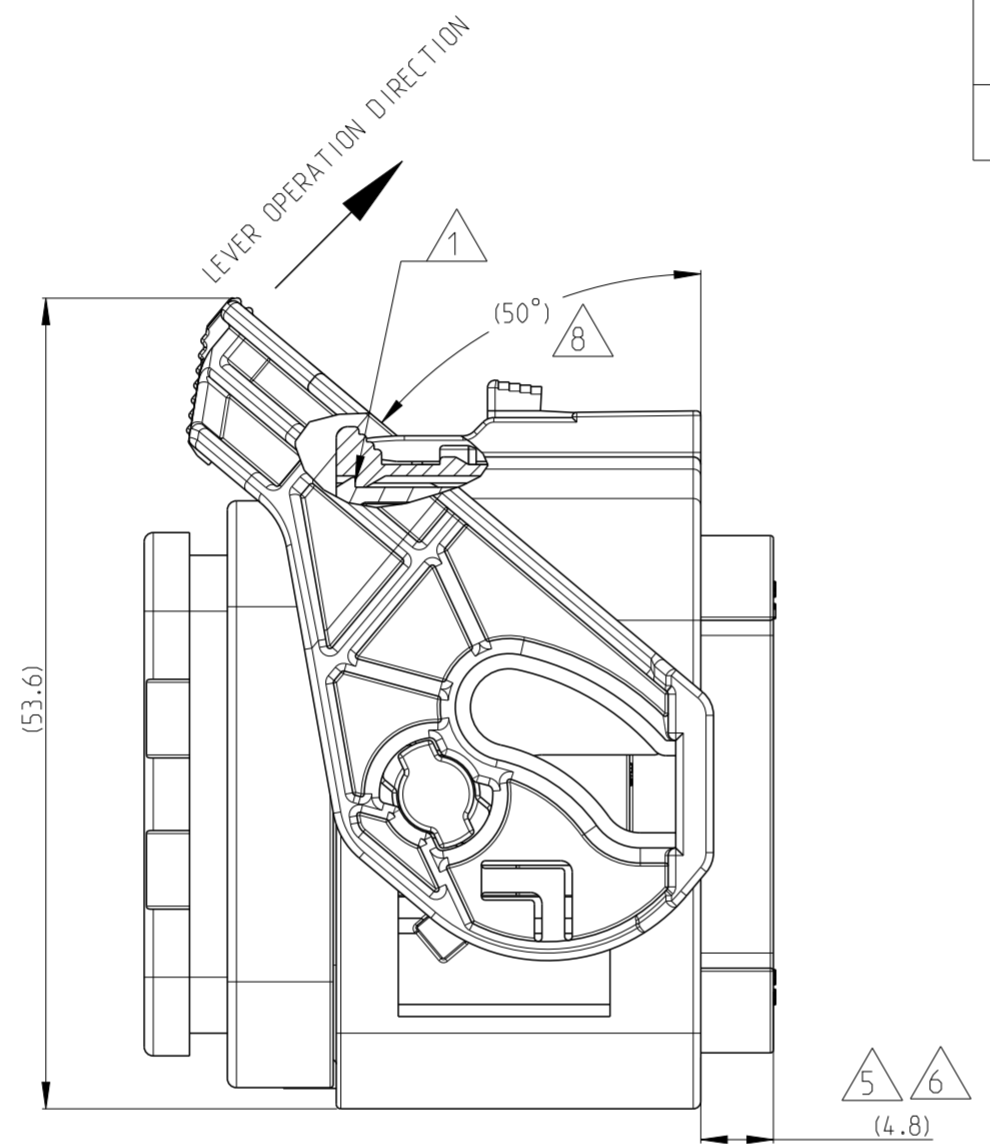
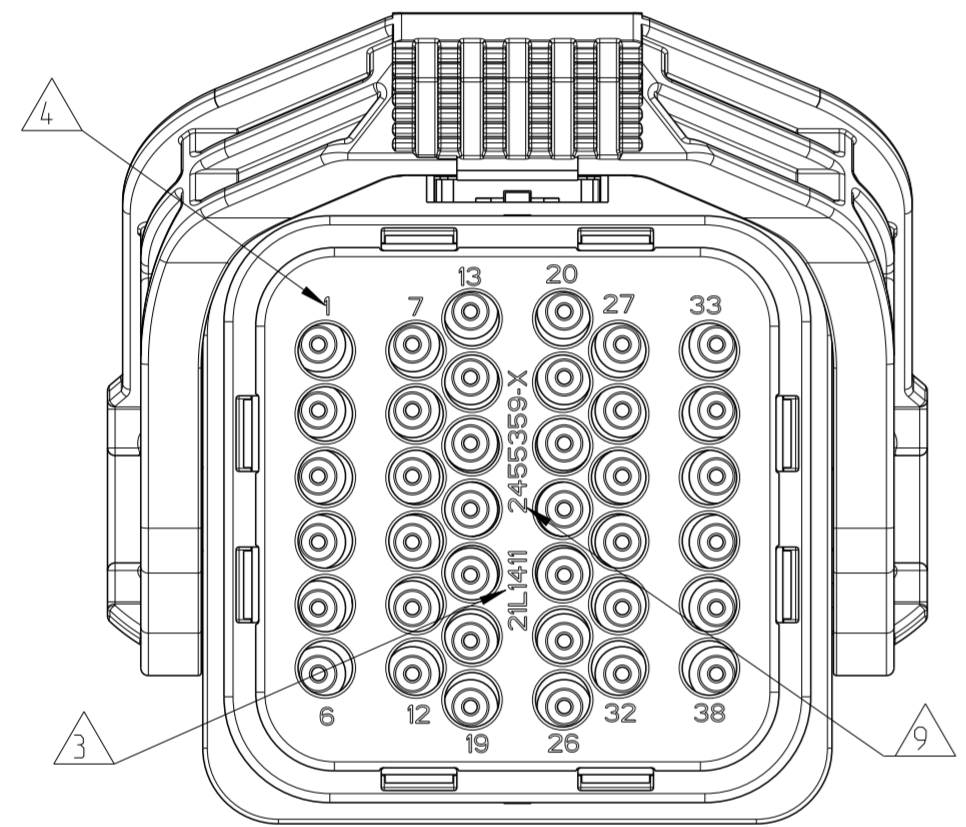
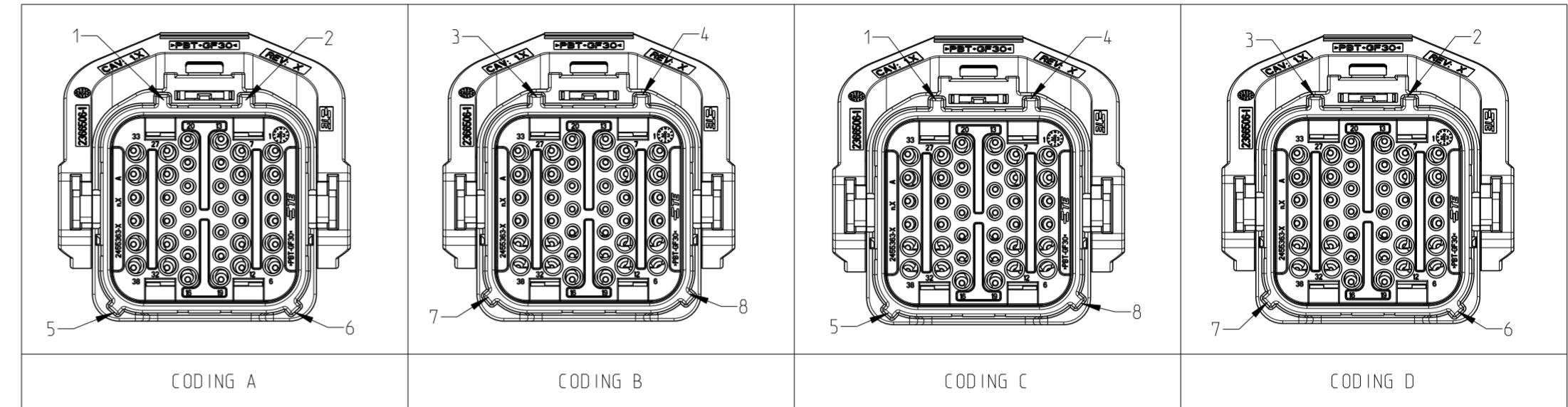
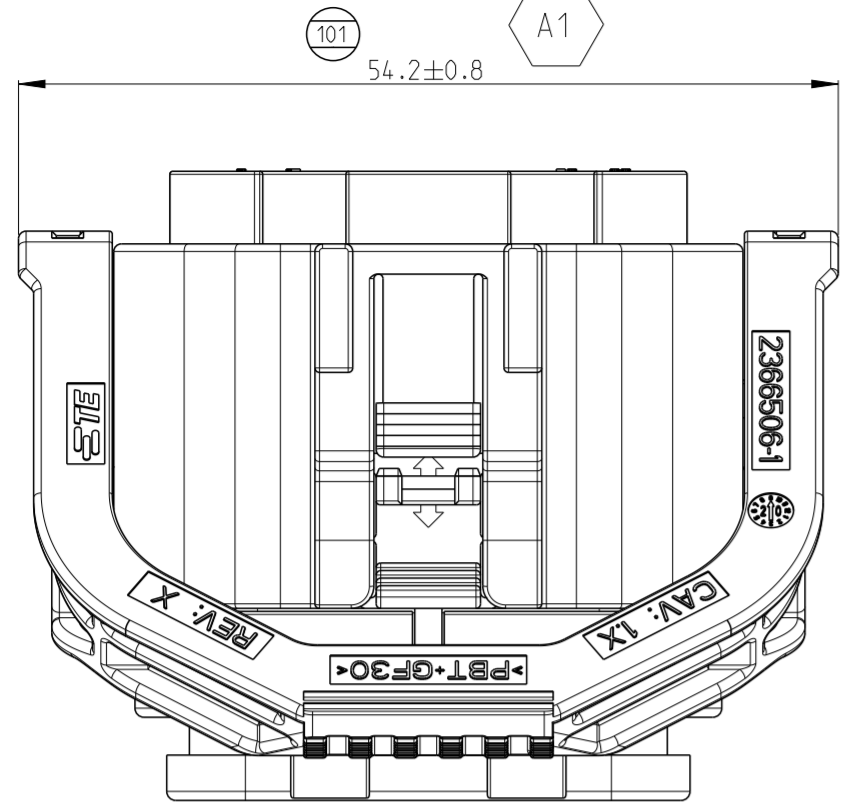

- THIS PLUG MATES WITH TAB HOUSING ASSEMBLY PN 2455360-X, OR 1-2455360-X (X=1, 2, 3, 4 FOR VARIOUS CODE).
- MATERIAL SEE TABLE
- DATE CODE: IDENTIFIES THE YEAR, MONTH, DAY AND HOUR OF ASSEMBLY.
YEAR: FIRST AND SECOND DIGITS(21-2021)
MONTH: THIRD DIGIT, EXCLUDING 1, A=JAN, B=FEB, C=MARCH...(M=DECEMBER)
DAY: FOURTH AND FIFTH DIGITS(14-14th DAY)
HOUR: SIXTH AND SEVENTH DIGITS(11-11AM)
- IDENTIFICATION FOR CABLE PINOUT.
- TPA AND CPA SEATED ON PRE-LOCK POSITION FOR DELIVERY.
- PULL TPA TO PRE-LOCK BEFORE TERMINAL INSERTION IN CASE OF TPA BEING HIT TO END-LOCK POSITION.
- REFER TO 114-151001 FOR DT SIZE 16 TERMINAL APPLICATION SPECIFICATION. APPLICABLE TERMINAL PART NUMBERS AND WIRE SIZE:

TERMINAL PN	WIRE SIZE (MM2)	INSULATION WIRE (MM)	PINOUT NUMBER
16#	0.75-2.5	Ø1.7-Ø3.0	ALL

- LEVER SEATED ON PRE-LOCK POSITION FOR DELIVERY.
- LASER PRODUCT PN. SUCH AS "--1" MEANS 2455359-1.

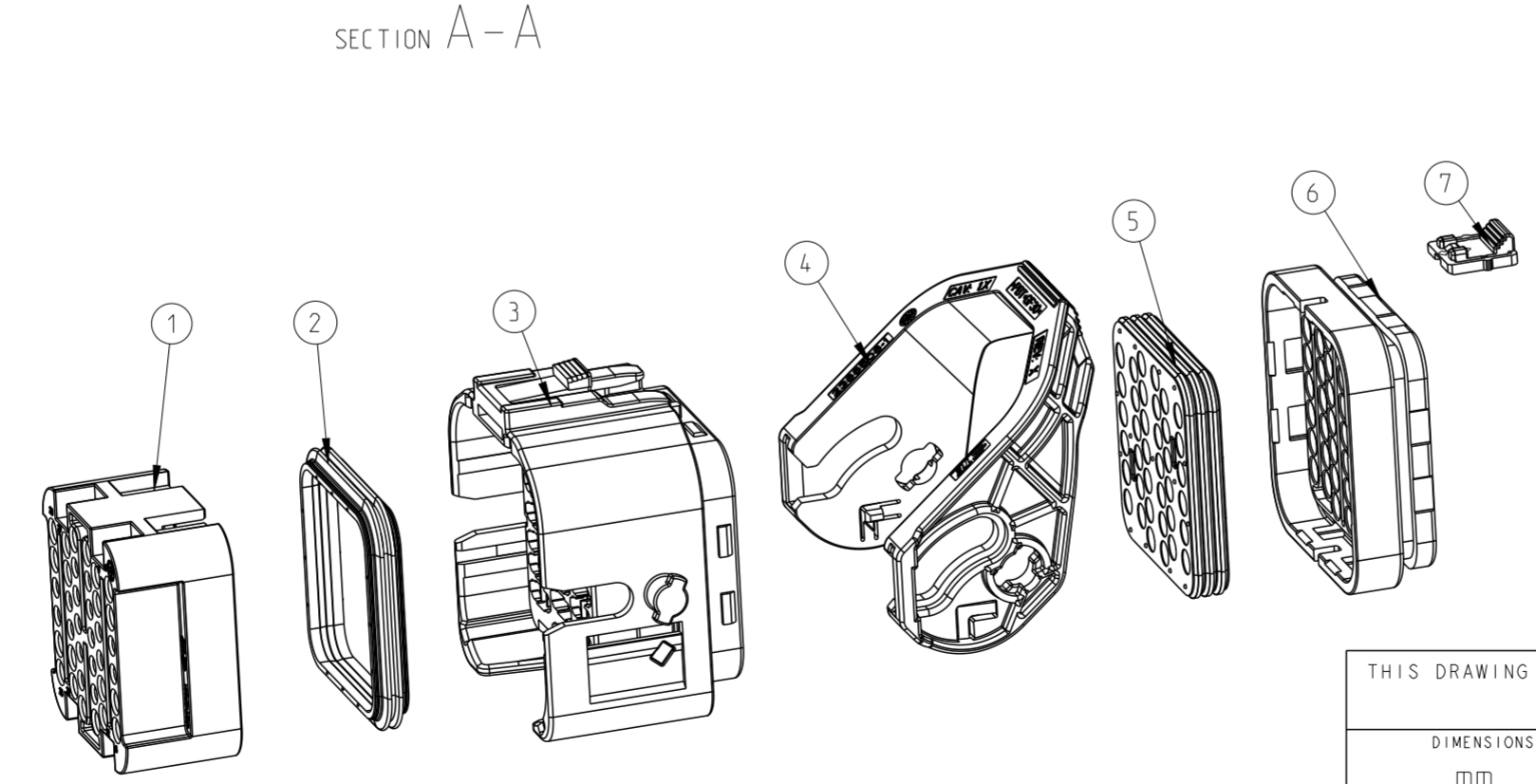
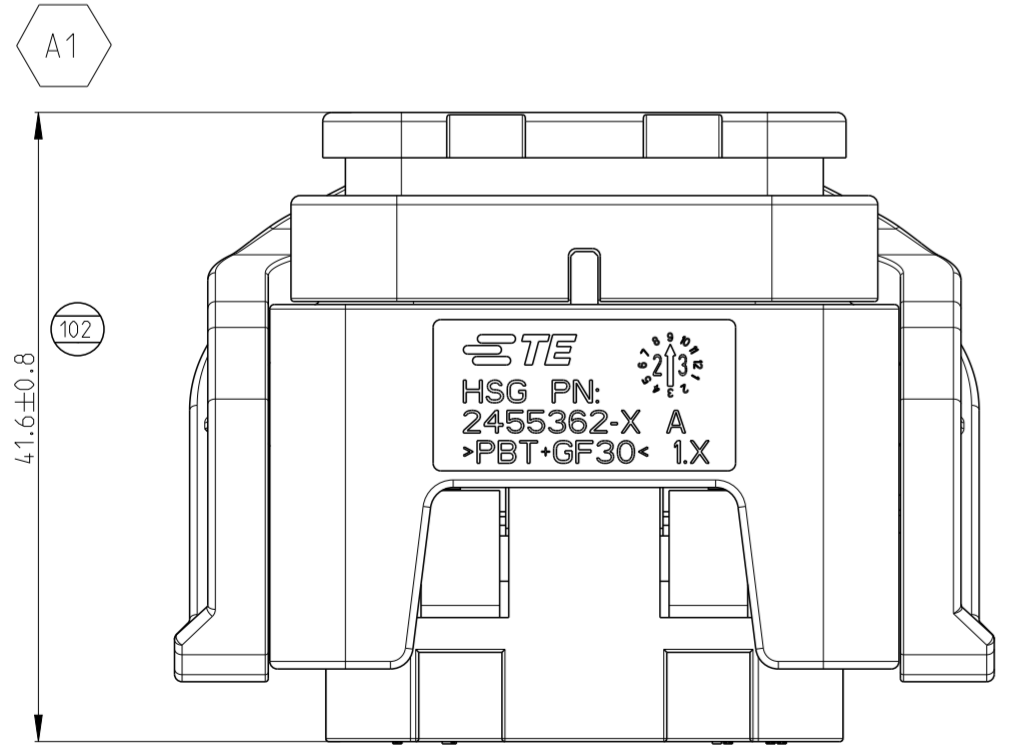

QTY.	REQUEST	PER ASSY	COLOR	MATERIAL	DESCRIPTION	ITEM NO
1	1	1	RED	PBT-GF15	CPA	7
1	-	-	BLUE	PBT-GF30	REAR CAP	6
-	1	-	GREEN			
-	-	1	GREY	PBT-GF30	HOUSING CODING D	3
-	-	1	BLACK			
1	1	1	RUST RED			
1	1	1	YELLOW	PBT-GF30	LEVER	4
1	-	-	BLUE	PBT-GF30	HOUSING CODING C	3
-	1	-	GREEN			
-	-	1	GREY			
-	-	-	BLACK	PBT-GF30	HOUSING CODING A	3
1	1	1	RUST RED			
1	1	1	YELLOW	PBT-GF30	TPA	1
QTY. REQUEST PER ASSY						
COLOR MATERIAL DESCRIPTION ITEM NO						
REVISION OF EACH ASSY PN						
TE ASSEMBLY PN						

THIS DRAWING IS A CONTROLLED DOCUMENT.

DIMENSIONS:	TOLERANCES UNLESS OTHERWISE SPECIFIED:
mm	
0 PLC	±
1 PLC	±
2 PLC	±
3 PLC	±
4 PLC	±
ANGLES	±
FINISH	

DWN J. SHANG 10SEP2023
CHK C. WAN 10SEP2023
APVD Z. ZHOU 10SEP2023

NAME NTS 38P PLUG ASSEMBLY

108-101662
114-32209

SIZE A2 CAGE CODE 00779 DRAWING NO. C-2455359 RESTRICTED TO -

CUSTOMER DRAWING SCALE 2:1 SHEET 1 OF 1 REV A1

Mouser Electronics

Authorized Distributor

Click to View Pricing, Inventory, Delivery & Lifecycle Information:

[TE Connectivity:](#)

[2455359-2](#)