

REVISIONS					
P	LTR	DESCRIPTION	DATE	DWN	APVD
A		PRODUCTION RELEASE PER ECN-22-148667	12APR2022	N.H	L.C
A1		REVISED PER ECR-22-149133	18AUG2022	N.H	L.C

KEYING A SHOWN FOR 5 POSITION

KEYING B SHOWN FOR 5 POSITION

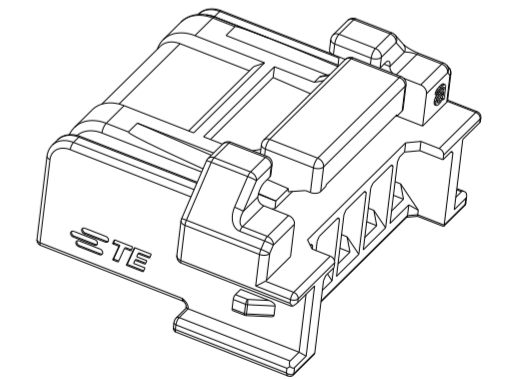
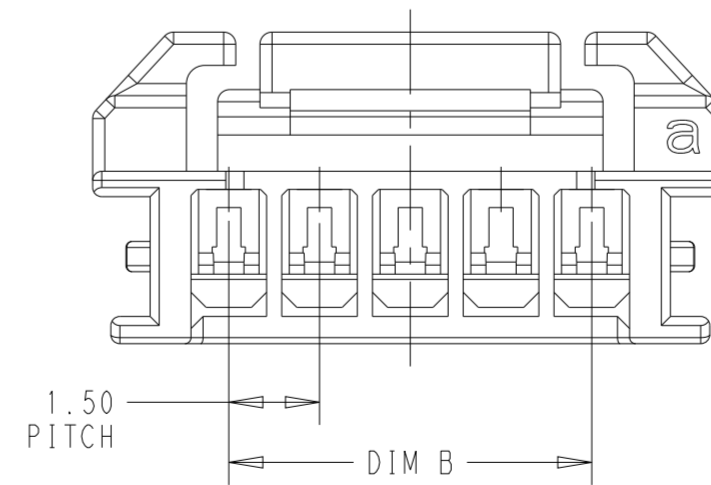
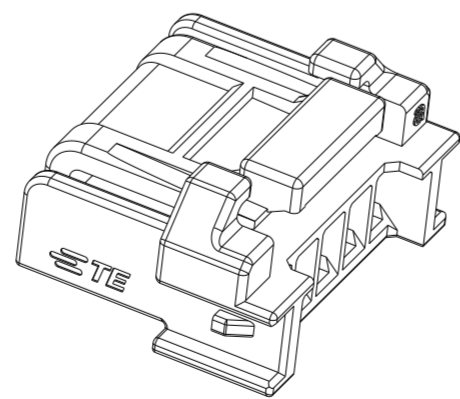
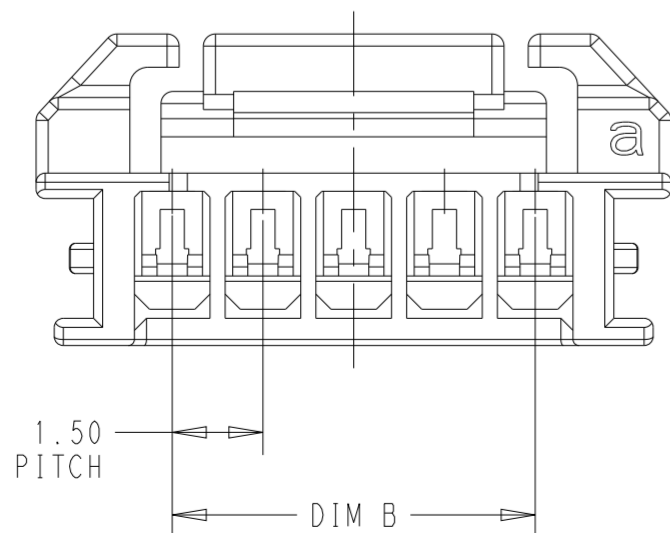
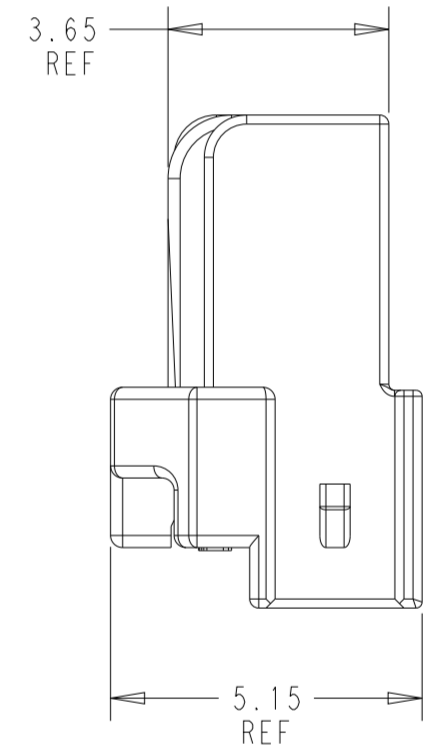
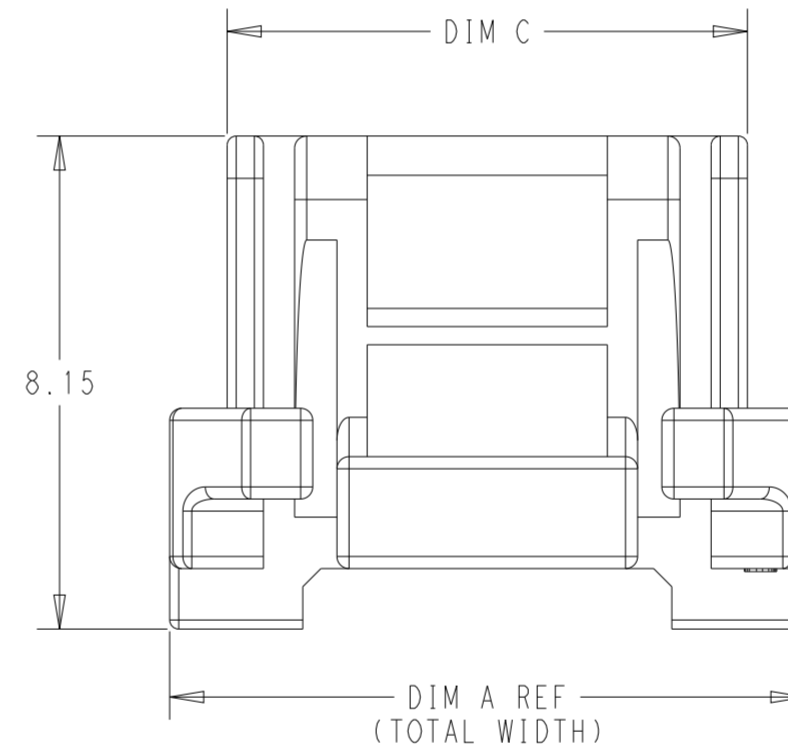
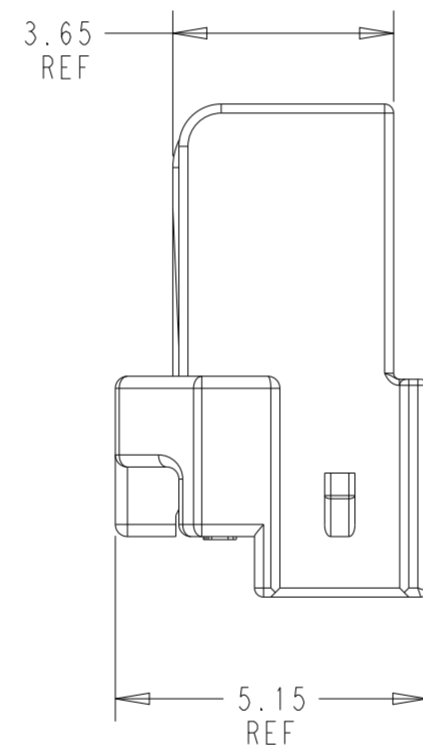
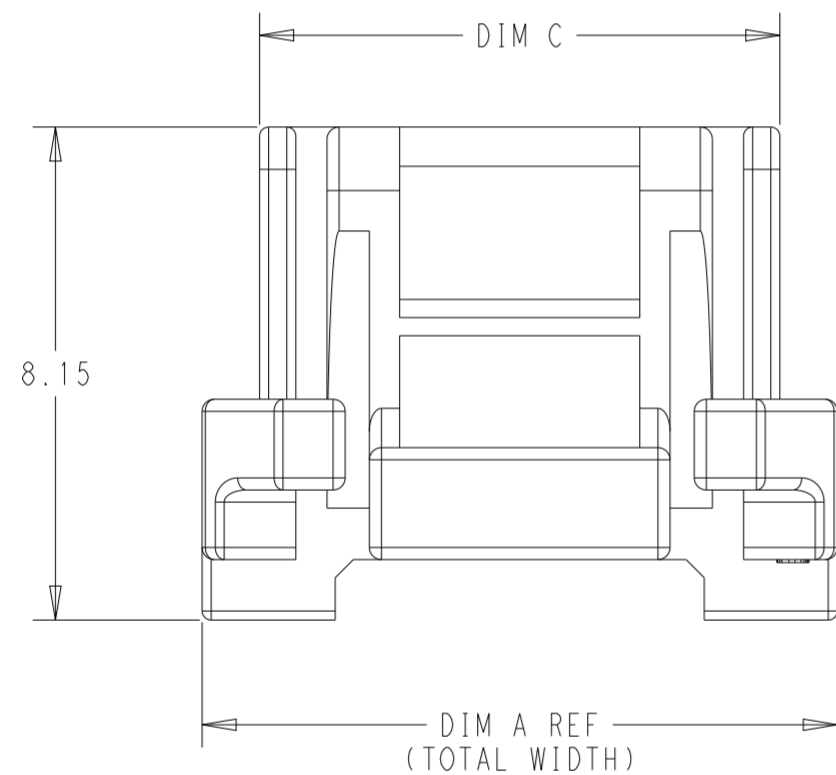
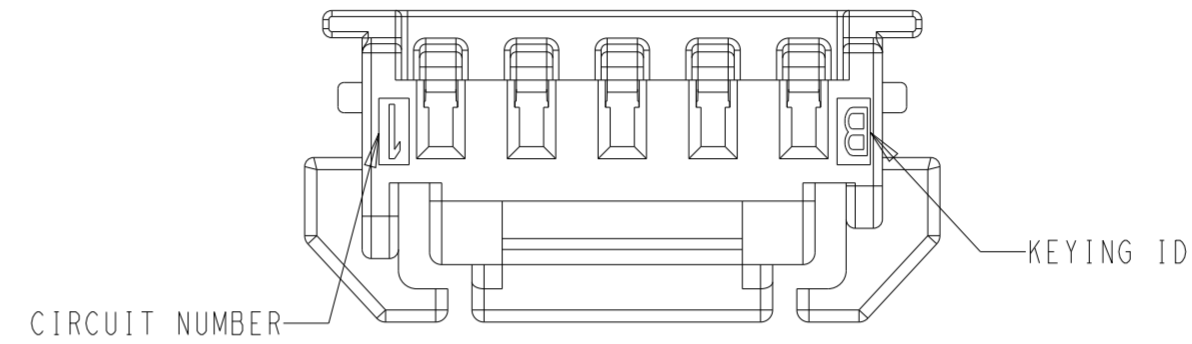
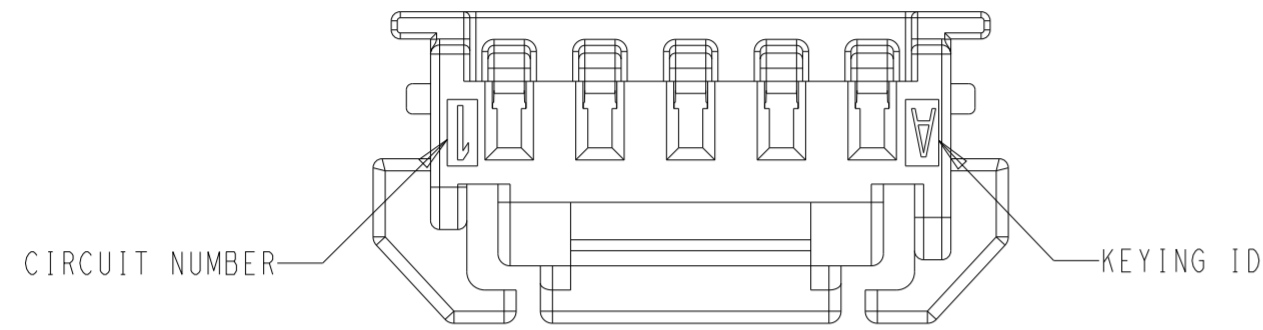

THIS DRAWING IS A CONTROLLED DOCUMENT.		DWN	LEO CHEN	13DEC2020	 TE Connectivity	NAME		PLUG HOUSING, CRIMP VERSION		
DIMENSIONS:		CHK	DANIEL ZHANG	13DEC2020		PRODUCT SPEC		SGI 1.50		
mm		APVD	DANIEL ZHANG	13DEC2020		APPLICATION SPEC		SIZE	CAGE CODE	DRAWING NO
0 PLC ± 1 PLC ±0.30 2 PLC ±0.15 3 PLC ± 4 PLC ± ANGLES ± FINISH -		MATERIAL		114-106497		108-106451	114-106497	A2	00779	C-2382946
 1		MATERIAL			WEIGHT		SCALE		8:1	
		CUSTOMER DRAWING			SHEET		1	OF	4	
					REV		A1			

P	LTR	DESCRIPTION	DATE	DWN	APVD
		SEE SHEET 1			

WIRE RANGE	MATING HEADER RA	MATING HEADER VT	DIM C	DIM B	DIM A	POS	KEYING	COLOR	PLUG PART NO
24-28AWG			4.1	1.5	6.23	2	A	NATURAL	2382946-2
			5.6	3.0	7.50	3			2382946-3
			7.1	4.5	9.00	4			2382946-4
			8.6	6.0	10.50	5			2382946-5
			10.1	7.5	11.40	6			2382946-6
			11.6	9.0	12.90	7			2382946-7
			13.1	10.5	14.40	8			2382946-8
			14.6	12.0	15.90	9			2382946-9
			16.1	13.5	17.40	10			1-2382946-0
			17.6	15.0	18.90	11			1-2382946-1
			19.1	16.5	20.40	12			1-2382946-2
			4.1	1.5	6.23	2	B	BLACK	2-2382946-2
			5.6	3.0	7.50	3			2-2382946-3
			7.1	4.5	9.00	4			2-2382946-4
			8.6	6.0	10.50	5			2-2382946-5
			10.1	7.5	11.40	6			2-2382946-6
			11.6	9.0	12.90	7			2-2382946-7
			13.1	10.5	14.40	8			2-2382946-8
			14.6	12.0	15.90	9			2-2382946-9
			16.1	13.5	17.40	10			3-2382946-0
			17.6	15.0	18.90	11			3-2382946-1
			19.1	16.5	20.40	12			3-2382946-2
			4.1	1.5	6.23	2	A	RED	4-2382946-2
			5.6	3.0	7.50	3			4-2382946-3
			7.1	4.5	9.00	4			4-2382946-4
			8.6	6.0	10.50	5			4-2382946-5
			10.1	7.5	11.40	6			4-2382946-6
			11.6	9.0	12.90	7			4-2382946-7
			13.1	10.5	14.40	8			4-2382946-8
			14.6	12.0	15.90	9			4-2382946-9
			16.1	13.5	17.40	10			5-2382946-0
			17.6	15.0	18.90	11			5-2382946-1
			19.1	16.5	20.40	12			5-2382946-2
			4.1	1.5	6.23	2	B	BLUE	6-2382946-2
			5.6	3.0	7.50	3			6-2382946-3
			7.1	4.5	9.00	4			6-2382946-4
			8.6	6.0	10.50	5			6-2382946-5
			10.1	7.5	11.40	6			6-2382946-6
			11.6	9.0	12.90	7			6-2382946-7
			13.1	10.5	14.40	8			6-2382946-8
			14.6	12.0	15.90	9			6-2382946-9
			16.1	13.5	17.40	10			7-2382946-0
			17.6	15.0	18.90	11			7-2382946-1
			19.1	16.5	20.40	12			7-2382946-2
			4.1	1.5	6.23	2	A	YELLOW	8-2382946-2
			5.6	3.0	7.50	3			8-2382946-3
			7.1	4.5	9.00	4			8-2382946-4
			8.6	6.0	10.50	5			8-2382946-5
			10.1	7.5	11.40	6			8-2382946-6
			11.6	9.0	12.90	7			8-2382946-7
			13.1	10.5	14.40	8			8-2382946-8
			14.6	12.0	15.90	9			8-2382946-9
			16.1	13.5	17.40	10			9-2382946-0
			17.6	15.0	18.90	11			9-2382946-1
			19.1	16.5	20.40	12			9-2382946-2

- 1 MATERIAL: NYLON, UL94V-0, COLOR: SEE TABLE.
- 2 THIS HOUSING ACCEPTS TERMINAL: 2371403-2.
- 3 RECOMMENDED MATING PART: SEE TABLE.
- 4 DIMENSIONS SHOWN REPRESENT PRODUCT IN DRY, AS MOLDED, CONDITION.

KEYING ILLUSTRATION

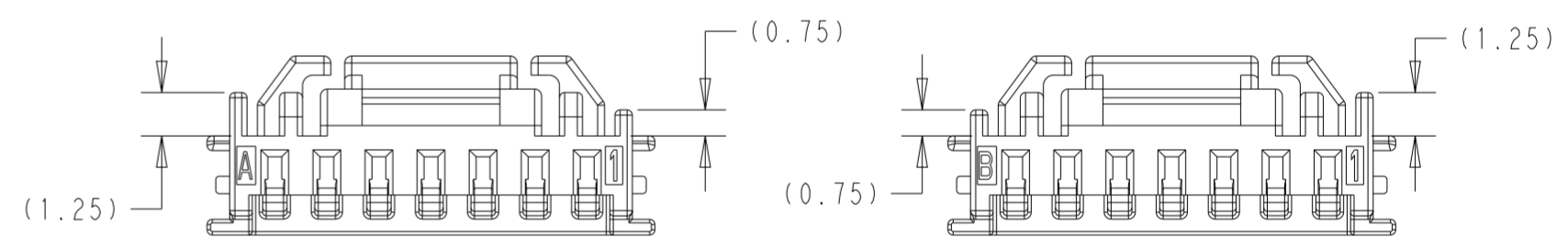

FOR 7 POS TO 12 POS

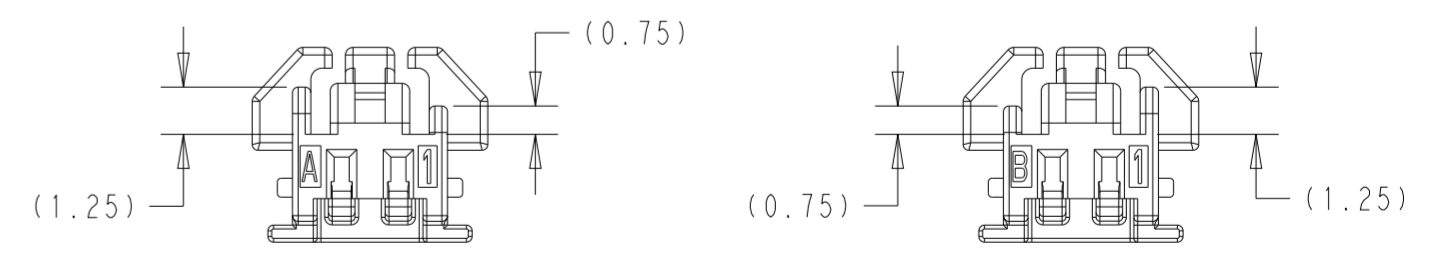

FOR 2 POS TO 6 POS

THIS DRAWING IS A CONTROLLED DOCUMENT.

DIMENSIONS: mm 	TOLERANCES UNLESS OTHERWISE SPECIFIED: 0 PLC ± 1 PLC ±0.30 2 PLC ±0.15 3 PLC ± 4 PLC ± ANGLES ± FINISH -	DWN LEO CHEN 13DEC2020	TE Connectivity
		CHK DANIEL ZHANG 13DEC2020	
MATERIAL 	FINISH -	APVD DANIEL ZHANG 13DEC2020	PRODUCT SPEC 108-106451
		APPLICATION SPEC 114-106497	RESTRICTED TO -
CUSTOMER DRAWING		WEIGHT -	SCALE 8:1
		SIZE A2	CAGE CODE 00779
		DRAWING NO C-2382946	SHEET 2 OF 4
		REV A1	

REVISIONS

P	LTR	DESCRIPTION	DATE	DWN	APVD
		SEE SHEET 1			

KEY A SHOWN FOR ALL POSITIONS

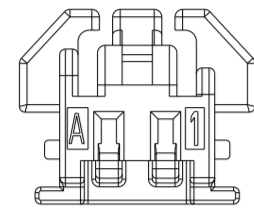

2 POSITION

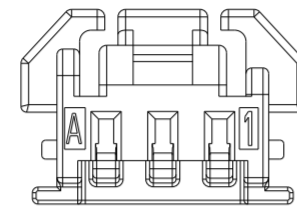

3 POSITION

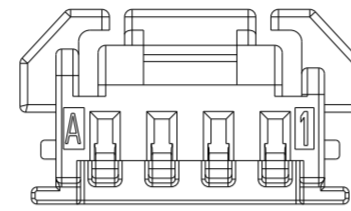

4 POSITION

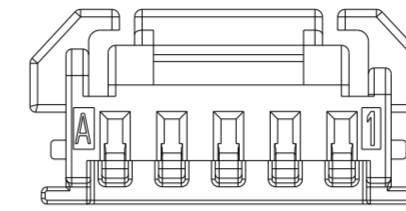

5 POSITION

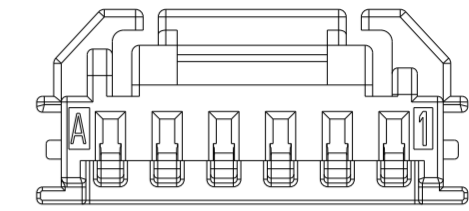

6 POSITION

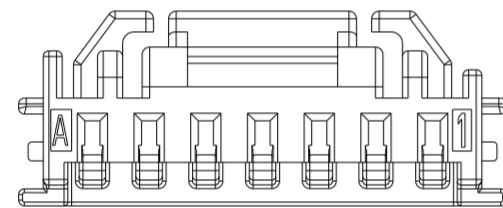

7 POSITION

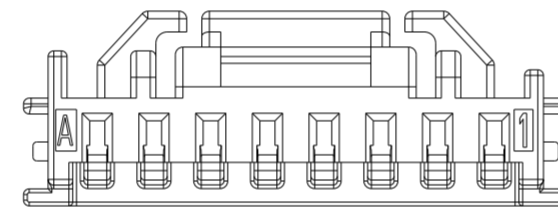

8 POSITION

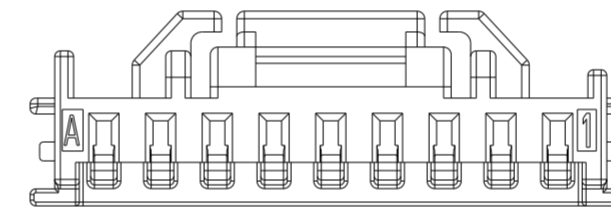

9 POSITION

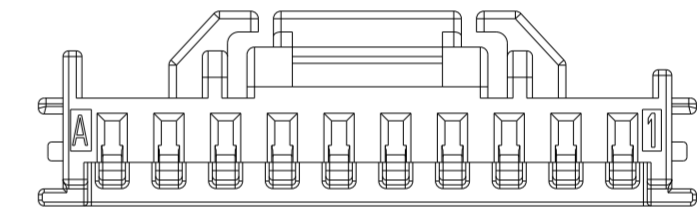

10 POSITION

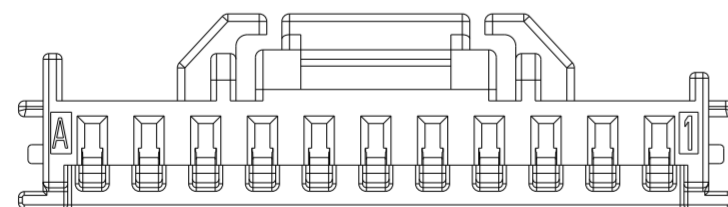

11 POSITION

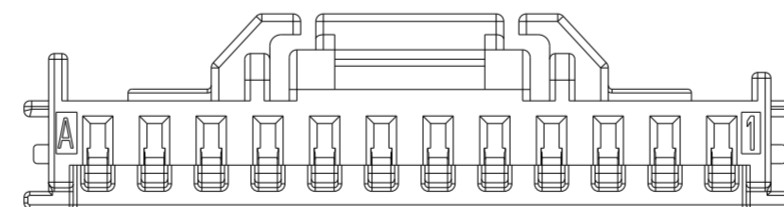

12 POSITION

THIS DRAWING IS A CONTROLLED DOCUMENT.		DWN LEO CHEN 13DEC2020				
		CHK DANIEL ZHANG 13DEC2020				
		APVD DANIEL ZHANG 13DEC2020	NAME PLUG HOUSING, CRIMP VERSION SGI 1.50			
DIMENSIONS: mm		PRODUCT SPEC 108-106451	SIZE A2	CAGE CODE 00779	DRAWING NO C-2382946	RESTRICTED TO -
TOLERANCES UNLESS OTHERWISE SPECIFIED: 0 PLC ± 1 PLC ±0.30 2 PLC ±0.15 3 PLC ± 4 PLC ± ANGLES ± FINISH -		APPLICATION SPEC 114-106497	SCALE 8:1		SHEET 3 OF 4	REV A1
MATERIAL 1		WEIGHT -	CUSTOMER DRAWING			

P	LTR	DESCRIPTION	DATE	DWN	APVD
		SEE SHEET 1			

KEY B SHOWN FOR ALL POSITIONS

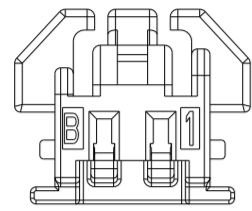

2 POSITION

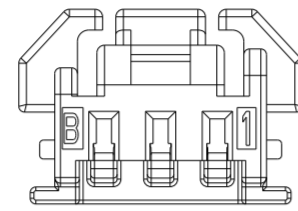

3 POSITION

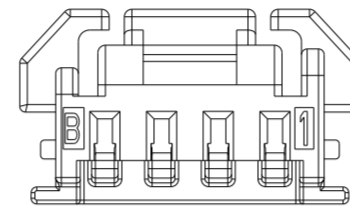

4 POSITION

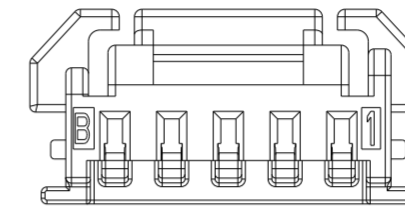

5 POSITION

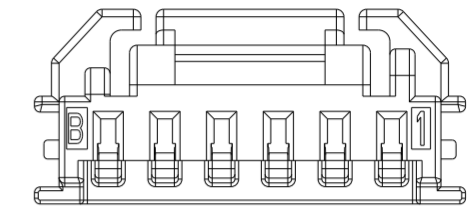

6 POSITION

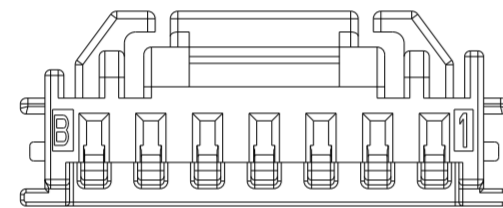

7 POSITION

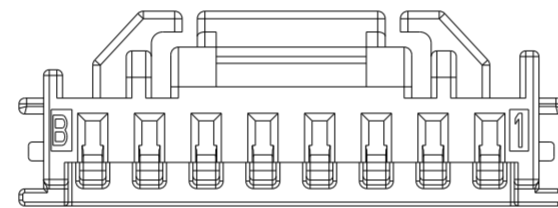

8 POSITION

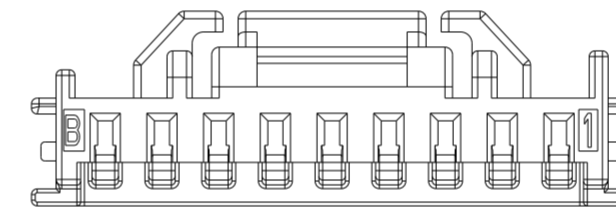

9 POSITION

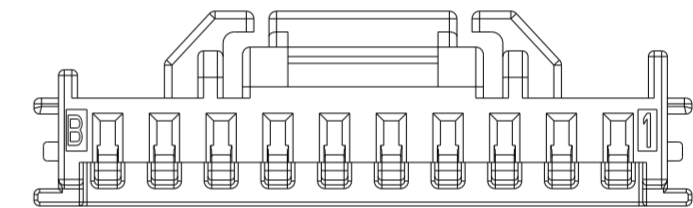

10 POSITION

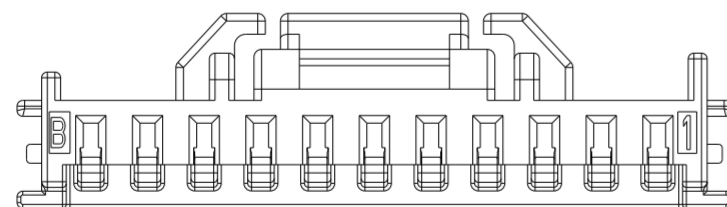

11 POSITION

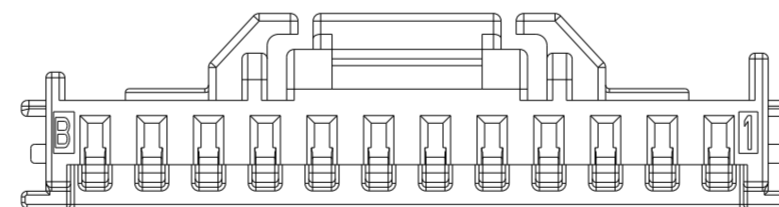

12 POSITION

THIS DRAWING IS A CONTROLLED DOCUMENT.		DWN LEO CHEN 13DEC2020				
		CHK DANIEL ZHANG 13DEC2020				
		APVD DANIEL ZHANG 13DEC2020	NAME PLUG HOUSING, CRIMP VERSION SGI 1.50			
DIMENSIONS: mm		PRODUCT SPEC 108-106451	SIZE A2	CAGE CODE 00779	DRAWING NO C-2382946	RESTRICTED TO -
TOLERANCES UNLESS OTHERWISE SPECIFIED: 0 PLC ± 1 PLC ±0.30 2 PLC ±0.15 3 PLC ± 4 PLC ± ANGLES ± FINISH -		APPLICATION SPEC 114-106497	WEIGHT -	SCALE 8:1	SHEET 4 OF 4	REV A1
MATERIAL 1		CUSTOMER DRAWING				

Mouser Electronics

Authorized Distributor

Click to View Pricing, Inventory, Delivery & Lifecycle Information:

[TE Connectivity:](#)

[1-2382946-1](#) [2382946-4](#) [2382946-7](#) [1-2382946-2](#) [2382946-2](#) [2382946-9](#) [2382946-6](#) [2382946-3](#) [2382946-8](#) [1-2382946-0](#)