

CENTER CONTACT 2327554-1, RTK031  
Innenleiter Kontakt 2327554-1, RTK031

REVISIONS					
P	LTR	DESCRIPTION	DATE	DWN	APVD
	B	INITIAL RELEASE	28OCT2021	SA	CS
	C	INCREASED CONTACT LAMELLA	15SEP2023	SA	CS

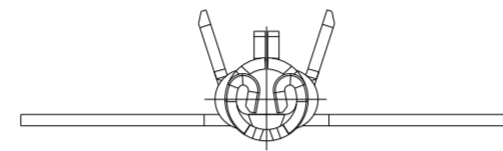
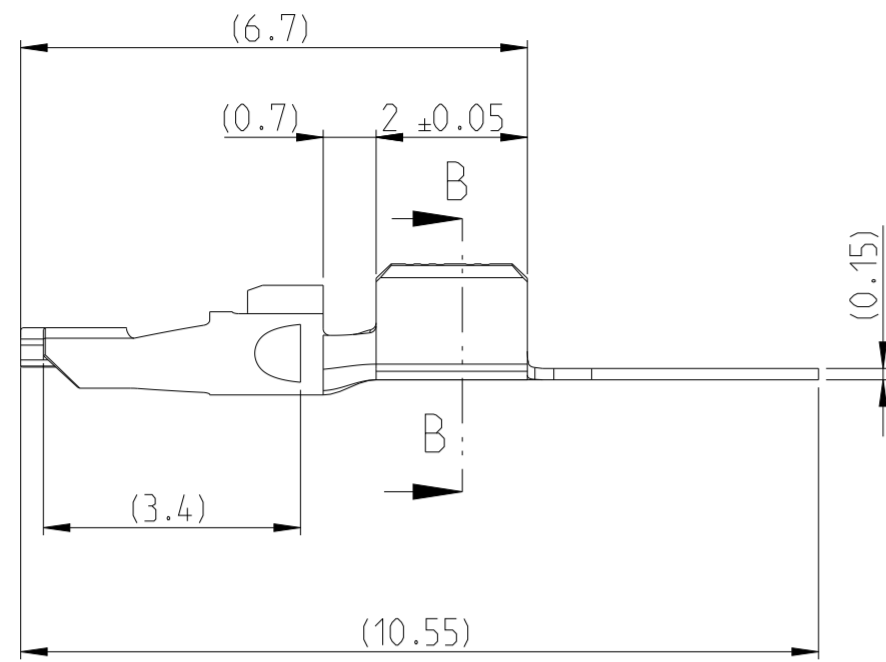

NOTES

1. PACKAGING: PRODUCT REELED ON CORRUGATED REEL WITH INTERLEAVING PAPER  
Verpackung: Spulenware auf Wellpappespule mit Zwischenlagenpapier
2. WEIGHT INCLUDING CARRIER STRIP  
Gewicht mit Trägerstreifen
3. MICROSECTION FOR CRIMP INSPECTION HAVE TO BE DONE ON SHOWN POSITION  
Schliffbild zur Crimpüberwachung ist bei angezeigter Position durchzuführen
4. UNSEALED APPLICATION/ Ungedichtete Applikation 114-94566  
SEALED APPLICATION/ Gedichtete Applikation 114-94705

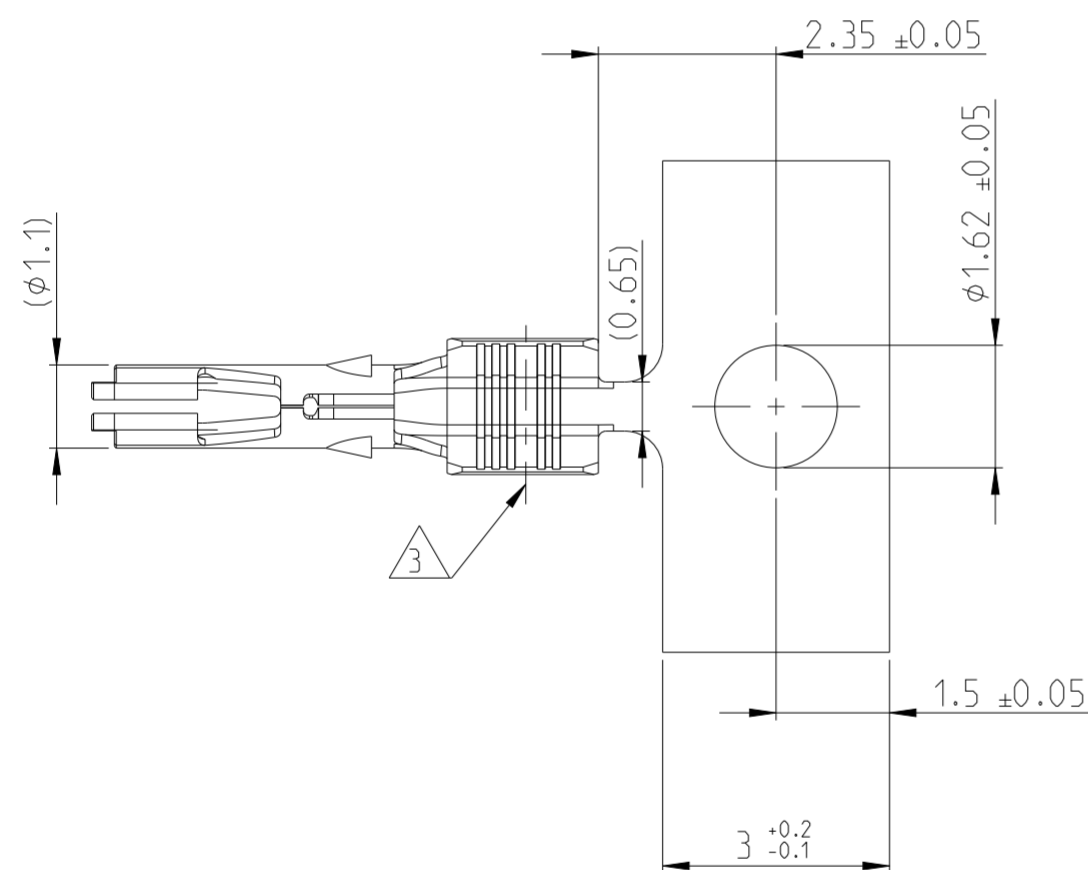

SECTION B-B  
20:1

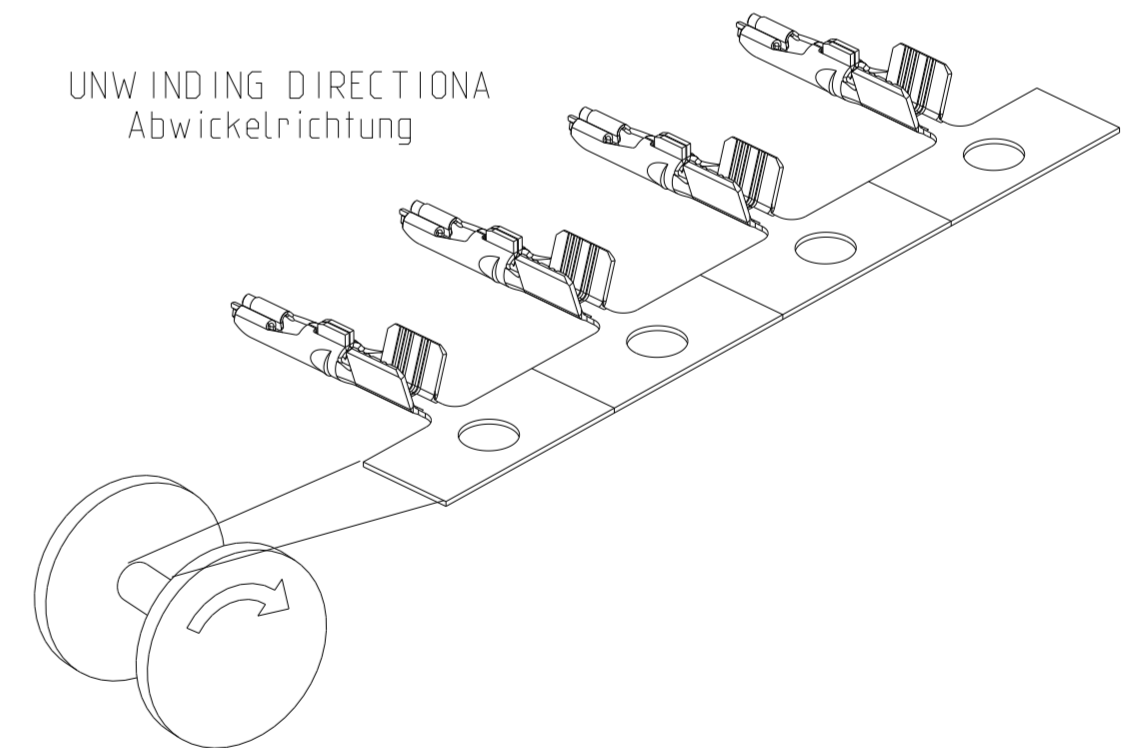
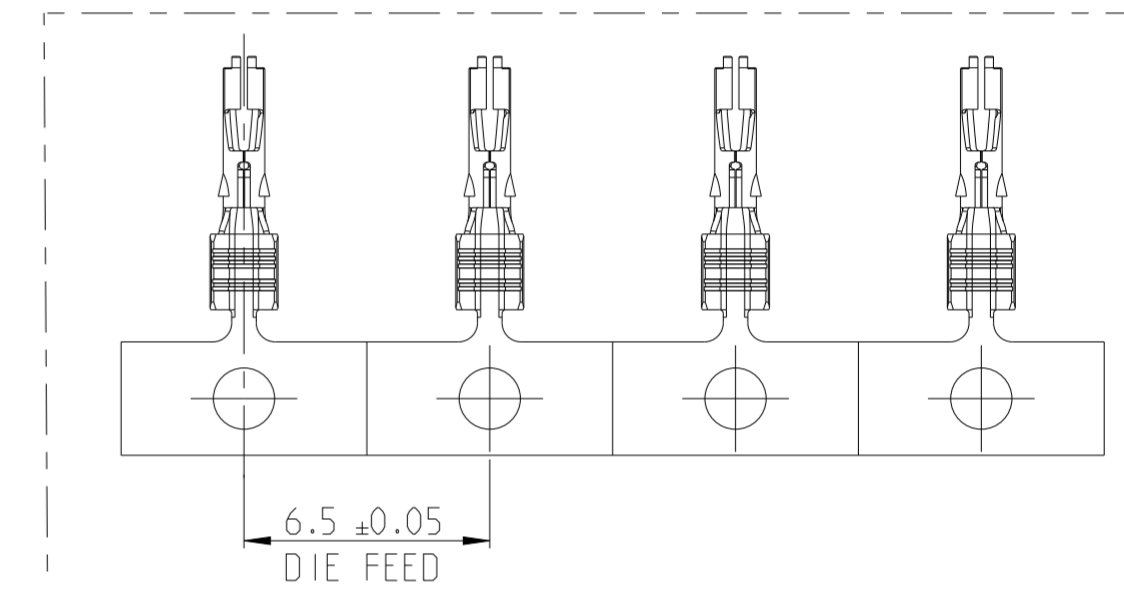
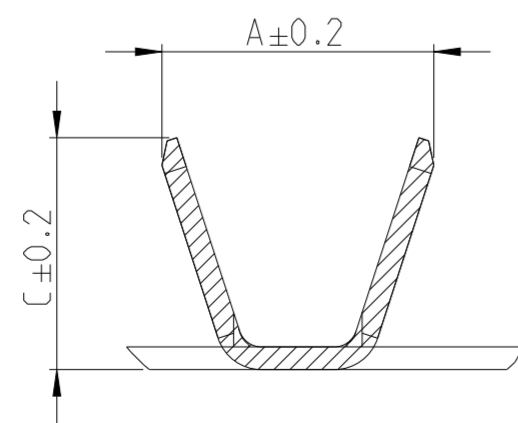

1.5	1.7	0.061	RG174	0.14mm <sup>2</sup>	Sn	CuSn	C	2327554-2
1.53	1.8	0.047	RTK031	0.35mm <sup>2</sup>	Sn	CuSn	C	2327554-1
C	A	WEIGHT [g]	CABLE TYPE	WIRE RANGE	SURFACE	MATERIAL	REV	PART NO.

THIS DRAWING IS A CONTROLLED DOCUMENT.

DIMENSIONS: mm	TOLERANCES UNLESS OTHERWISE SPECIFIED:	DWN Raghavendra M 11OCT2021 CHK S.Aboukassem 13DEC2021 APVD C.Schrettlinger 13DEC2021	TE Connectivity	
0 PLC ±0.2 1 PLC ±0.1 2 PLC ±0.1 3 PLC ± 4 PLC ± ANGLES ±° FINISH -	PRODUCT SPEC 108-94515 APPLICATION SPEC 4 WEIGHT SEE TABLE A2 CUSTOMER DRAWING	NAME MATE-AX, 90DEG, CENTER CONTACT CABLE SIDE SIZE CAGE CODE DRAWING NO RESTRICTED TO A2 00779 C-2327554 -		
SCALE 10:1			SHEET 1 OF 2 REV C	

CENTER CONTACT 2327554-2, RG174  
 Innenleiter Kontakt 2327554-2, RG174

REVISIONS

P	LTR	DESCRIPTION	DATE	DWN	APVD
-		SEE SHEET 1	-	-	-

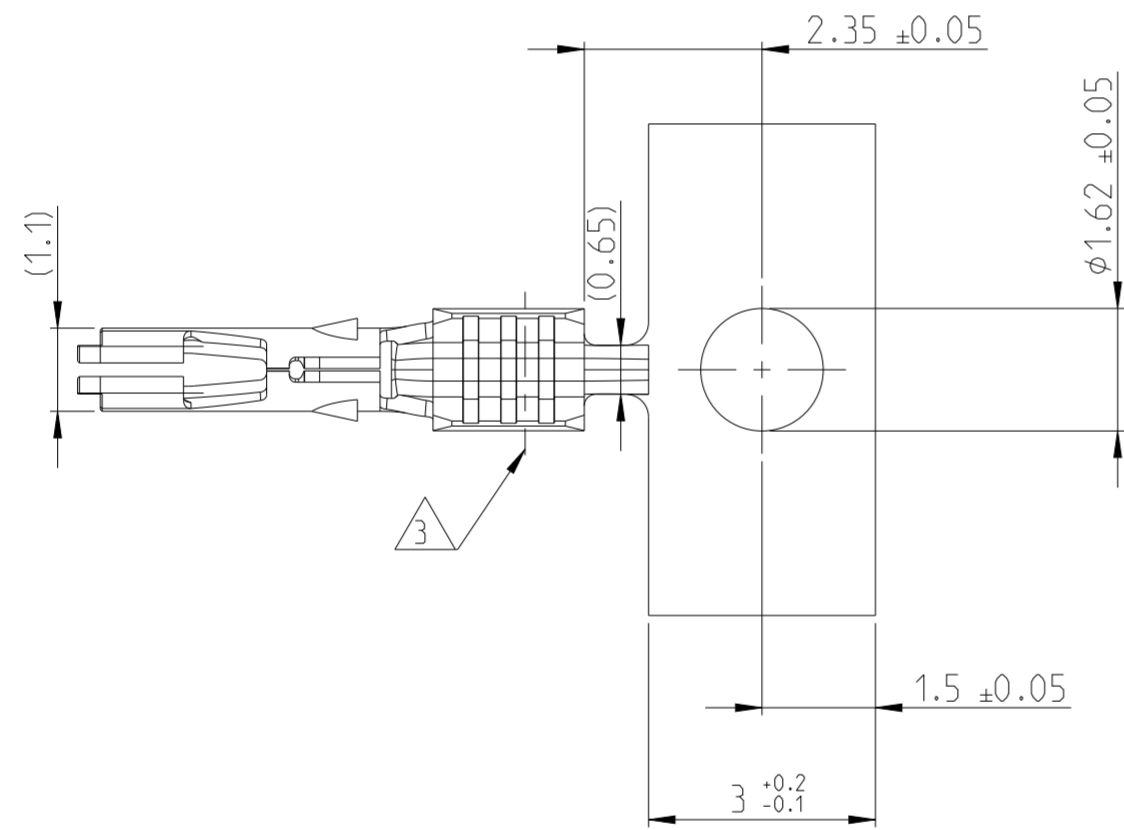
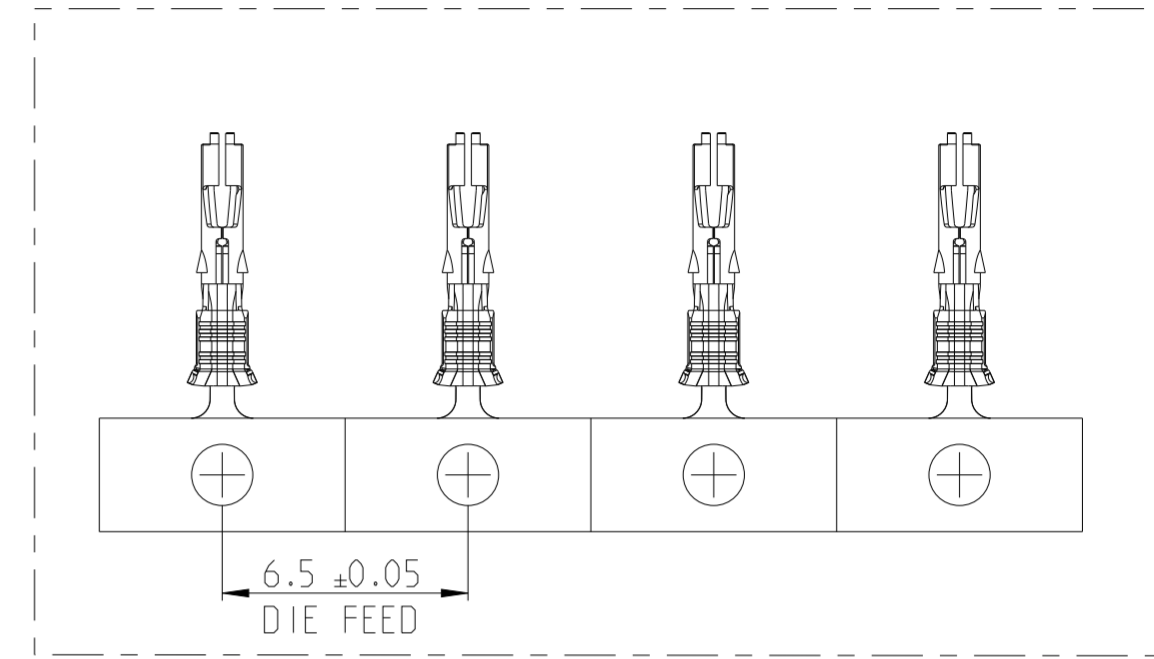
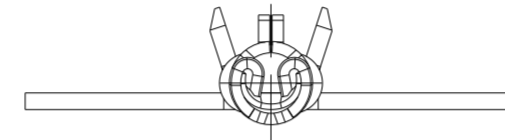
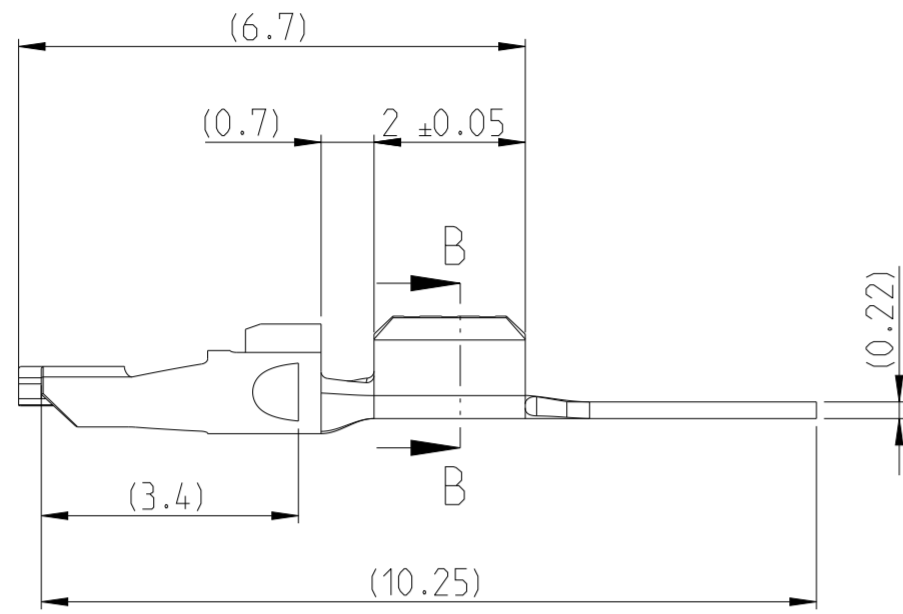

SECTION B-B  
20:1

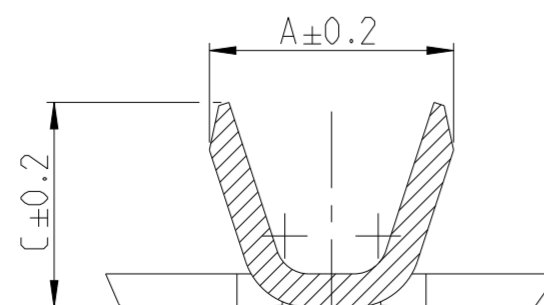

UNWINDING DIRECTION  
Abwickelrichtung

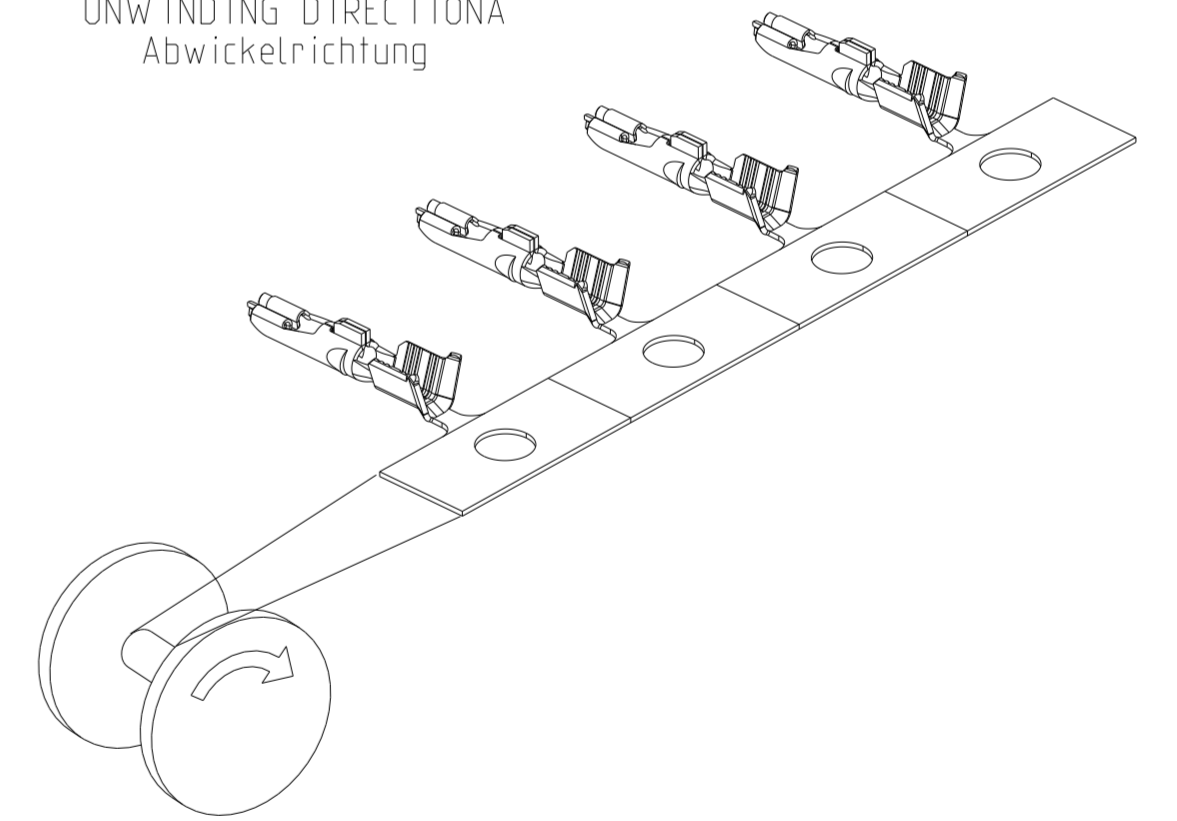

THIS DRAWING IS A CONTROLLED DOCUMENT.		DWN 11OCT2021 Raghavendra M	<b>STE</b> TE Connectivity	
DIMENSIONS: mm		CHK 13DEC2021 S.Aboukassem		
TOLERANCES UNLESS OTHERWISE SPECIFIED:		APVD 13DEC2021 C.Schrettlinger	NAME MATE-AX, 90DEG, CENTER CONTACT CABLE SIDE	
0 PLC ±0.2		PRODUCT SPEC 108-94515	RESTRICTED TO	
1 PLC ±0.1		APPLICATION SPEC	SIZE	CAGE CODE
2 PLC ±0.1		ANGLE	4	00779
3 PLC ±		FINISH	SCALE	DRAWING NO
4 PLC ±			10:1	C-2327554
MATERIAL		WEIGHT	SHEET	REV
-		SEE TABLE A2	2 OF 2	C
-		CUSTOMER DRAWING		

# Mouser Electronics

Authorized Distributor

Click to View Pricing, Inventory, Delivery & Lifecycle Information:

[TE Connectivity:](#)

[2327554-1](#) [2327554-2](#)