

ohne Ansaughaube
without hood

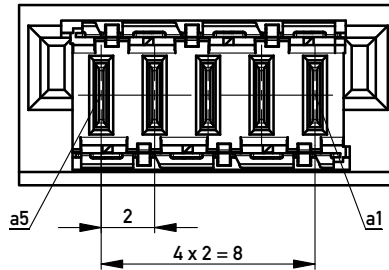

Verpackt in Gurtverpackung
Tape on Reel Packaging
Verpackungseinheit: 220 Stück
Packaging unit: 220 pcs

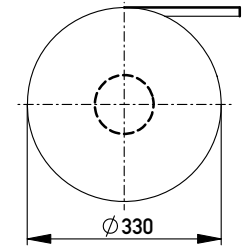

Abspulrichtung - Reel off Direction

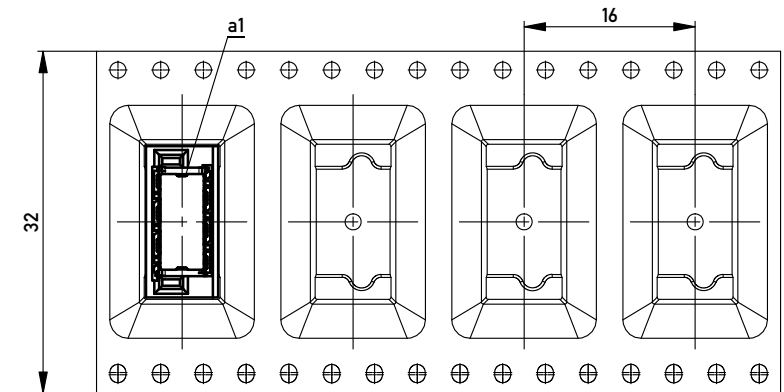

Leiterplatten-Layout Vorschlag / PCB-layout proposal

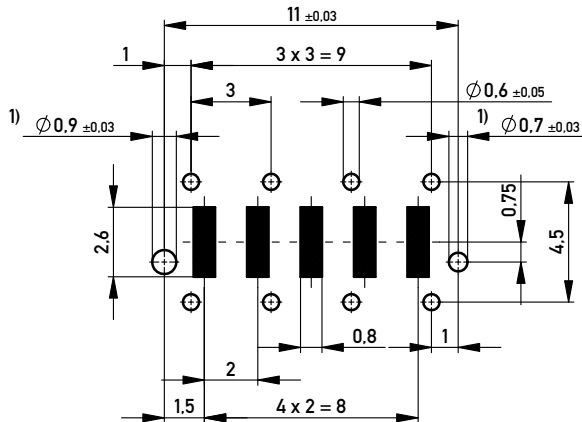

1) Durchmesser des Bohrers / drill tool

Anforderungsstufe 1
Performance Level 1

Kontaktbereich vergoldet
Mating Area gold plating

Anschlussbereich verzinkt 4-6µm
Terminal Area 4-6µm tin plating

Koplanarität der Anschlüsse ≤ 0,1mm
Coplanarity Area of Termination ≤ 0,1mm

Information:	Tolerances	 All Dimensions in mm	Scale	5:1
	All rights reserved. Only for Information. To ensure that this is the latest version of this drawing, please contact one of the ERNI companies before using.			
Subject to modification without prior notice. Drawing will not be updated.	Designation			
	M10 MSPEED Blind Mate PM THR			
 www.ERNI.com	354282			I
	Class MSPEED			A3
e	12.09.2012	Date		
Index				

Copyright by ERNI GmbH. Proprietary notice pursuant to ISO 9006 to be observed.

Mouser Electronics

Authorized Distributor

Click to View Pricing, Inventory, Delivery & Lifecycle Information:

[TE Connectivity:](#)

[354282](#) [354282-E](#)