

THIS DRAWING IS UNPUBLISHED. RELEASED FOR PUBLICATION
 © COPYRIGHT - By - ALL RIGHTS RESERVED.

LOC		DIST		REVISIONS			
P	LTR	DESCRIPTION		DATE	DWN	APVD	
	P1	REVISED PER ECO-11-005030		11MAR11	RK	HMR	

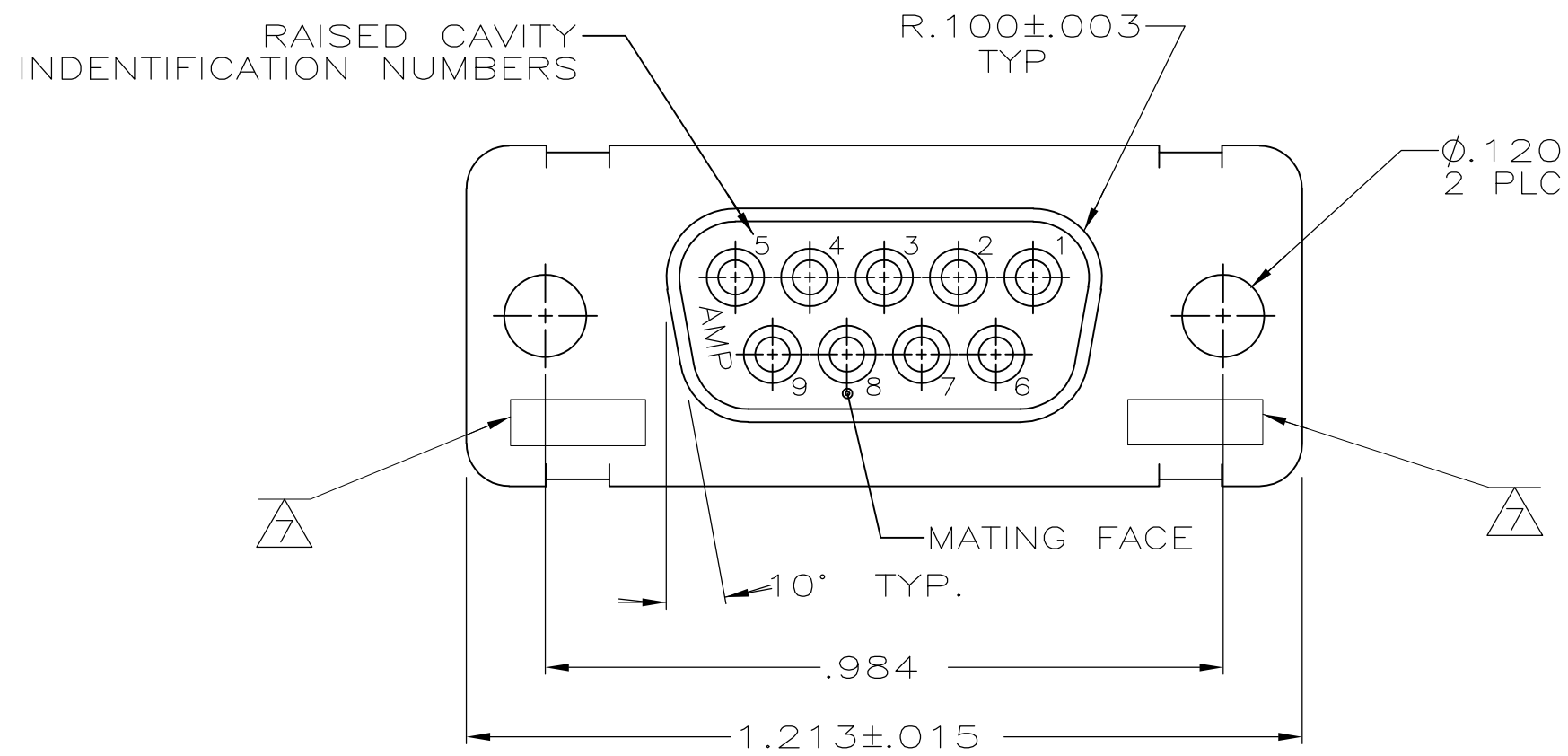

- THIS RCPT. IS DESIGNED TO CONFORM TO THE LATEST ISSUE OF MIL-C-24308
 - MAX WIRE INSUL TO BE USED WITH THIS RCPT IS .068 DIA
 - STAINLESS STEEL RETENTION CLIPS ARE INCLUDED IN INSERTS
 - PACKAGE STAMPED M24308/2-281F
 - THIS RCPT. WILL ACCEPT SIZE 20 SOCKET CONTACT M39029/63-368 OR ANY AMP HD-20 SOCKET CONTACT
- △6 AMP PART NO. STAMPED ON CONNECTOR REPRESENTS KIT NUMBER WITH CONTACTS
 - △7 UL/CSA DESIGNATION STAMPED IN THIS AREA.
 - △8 RESTRICTED ITAR DRAWING.
 - △9 FINISH: PLATED BRIGHT TIN .000400 MIN THK PER ASTM-B-545 OVER COPPER PLATE .000050 MIN THK PER MIL-C-14550.

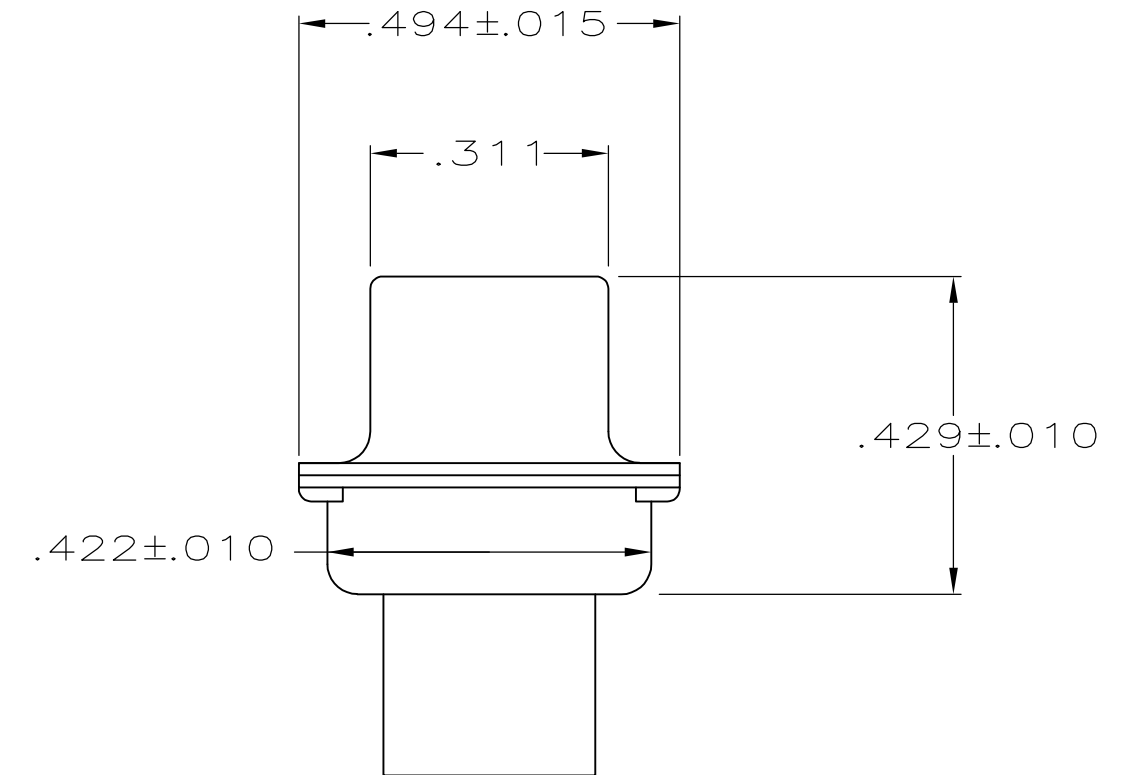
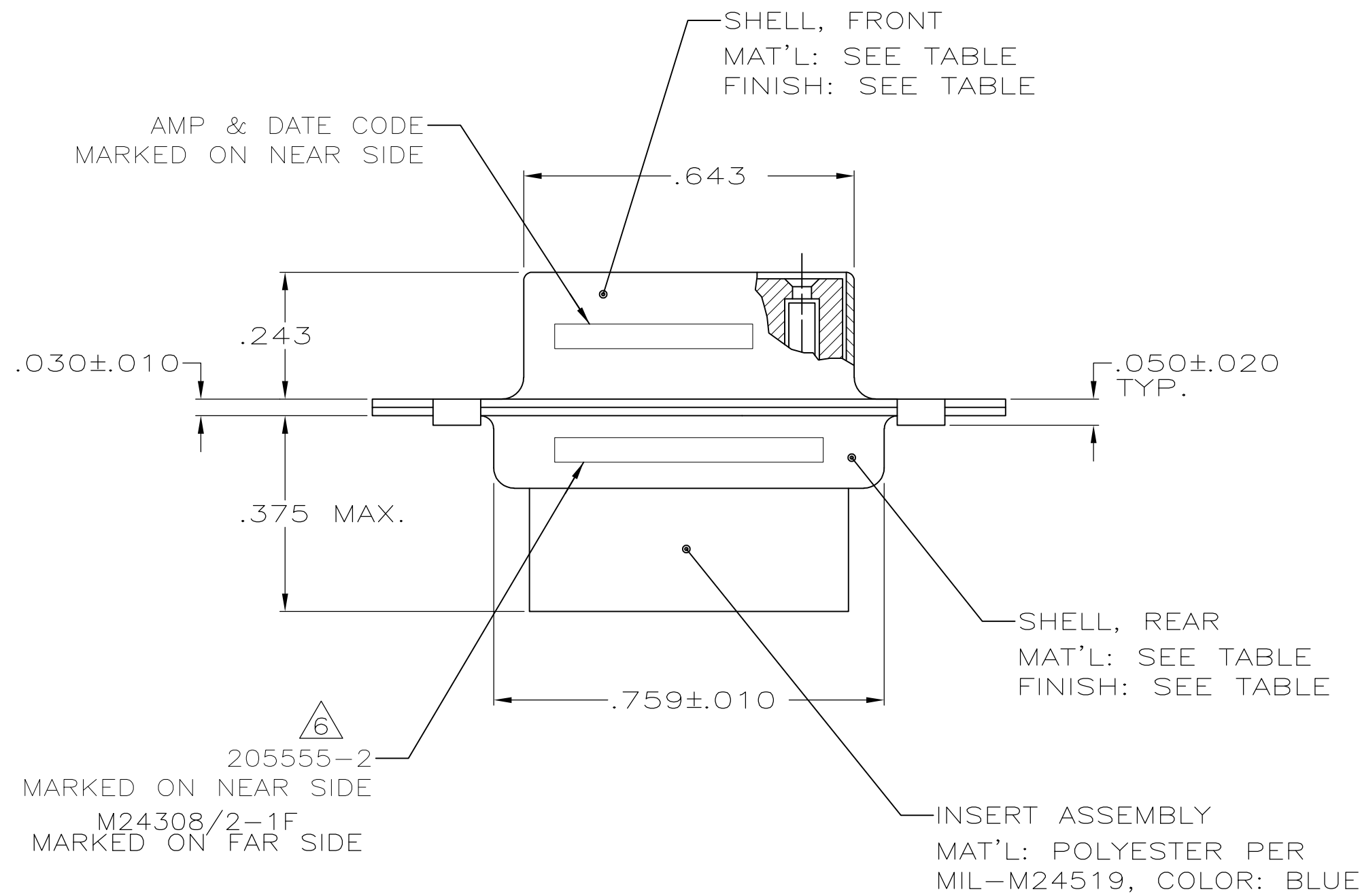

	△9	STEEL, CLASS G	205161-5
	△8	-	205161-4
SUPSC BY 205161-1		CADMIUM PER QQ-P-416	STEEL, CLASS G
SUPSD BY 207253-2		CADMIUM PER QQ-P-416	BRASS
		CADMIUM PER QQ-P-416	STEEL, CLASS G
		SHELL FINISH	SHELL MATERIAL
			PART NUMBER

THIS DRAWING IS A CONTROLLED DOCUMENT.		DWN C.C.THOMAS 1-12-05	STE TE Connectivity	
DIMENSIONS: INCHES		CHK D.MILLER 1-12-05		
TOLERANCES UNLESS OTHERWISE SPECIFIED:		APVD D.MILLER 1-12-05	NAME RCPT ASSY,AMPLIMITE, SIZE 1,9 POSN,SERIES 109	
0 PLC ± - 1 PLC ± - 2 PLC ± - 3 PLC ± .005 4 PLC ± - ANGLES ± 0° 30'		PRODUCT SPEC -	RESTRICTED TO -	
MATERIAL SEE CALLOUTS		APPLICATION SPEC -	SIZE A2	CAGE CODE 00779
FINISH SEE CALLOUTS		WEIGHT -	DRAWING NO C=205161	SCALE 4:1
		CUSTOMER DRAWING	SHEET 1 of 1	REV P1

Mouser Electronics

Authorized Distributor

Click to View Pricing, Inventory, Delivery & Lifecycle Information:

[TE Connectivity:](#)

[M24308/2-281F](#)