

PART NUMBER	REVISION	DESCRIPTION	FEED TYPE
2266669-1	C	FINE CRIMP HEIGHT ADJUST	MECHANICAL
2266669-2	D	FINE CRIMP HEIGHT ADJUST	PNEUMATIC
7-2266669-1	C	MECHANICAL AND CRIMP TOOLING KIT	MECHANICAL
7-2266669-2	D	PNEUMATIC AND CRIMP TOOLING KIT	PNEUMATIC
7-2266669-7	A	CRIMP TOOLING KIT	-

ATLANTIC VERSION TERMINATOR INTERFACE ADAPTER



APPLICATOR DATA		
CRIMP	SIZE	TYPE
WIRE	2.29 mm [.090]	F
INSUL	5.08 mm [.200]	F

APPLICATOR INSTRUCTIONS 408-35042

TERMINAL DATA: TE TERMINAL		TE CRIMP SPECIFICATION	
TERMINAL NAME: UNIVERSAL MATE-N-LOCK II			
WIRE STRIP LENGTH		INSULATION DIAMETER RANGE	
4.00-4.76 mm [.157-.187 IN]		Ø3.30-5.08 mm [.130-.200 IN]	
TERMINAL APPLICATION SPECIFICATION	114-1043		
TERMINALS APPLIED			
TE TERMINAL	TE TERMINAL	TE TERMINAL	TE TERMINAL
770005-1	770005-9	770006-3	770194-1
770005-3	1-770005-0	770006-4	770194-9
770005-8	1-770005-1	1-77000-0	1-770194-0

WIRE SIZE	CRIMP HEIGHT mm [INCH]	CRIMP HEIGHT REFERENCE SETTING
14 AWG	1.75+/-0.05 [.069+/- .002]	4.6
16 AWG	1.50+/-0.05 [.059+/- .002]	7.4
18 AWG	1.32+/-0.05 [.052+/- .002]	9.3
20 AWG	1.19+/-0.05 [.047+/- .002]	10.6

- 1. RECOMMENDED SPARE PARTS
- 2. REFER TO SUPPLIED INSTRUCTION SHEET FOR CLEANING, LUBRICATION AND STORAGE OF APPLICATOR.
- 3. APPLY PART NUMBER 2-23419-6 LOCTITE TO THREADS OF ITEM 242.
- 4. CRIMP HEIGHT REFERENCE SETTING WAS THE SETTING USED WHEN THE APPLICATOR WAS QUALIFIED AT THE FACTORY. ADJUSTMENT MAY BE NECESSARY WHEN RUNNING APPLICATOR IN THE FIELD.
- 5. UNLESS SPECIFIED OTHERWISE TORQUE VALUES SHALL BE USED PER DOCUMENT, 101-35000.

***WARNING**
ON INSTALLATION, SET WIRE DISC TO CRIMP HEIGHT REFERENCE SETTING FOR LARGEST WIRE SIZE. CRIMP HEIGHT REFERENCE SETTINGS GREATER THAN THE VALUE SHOWN MAY CAUSE DAMAGE TO THE CRIMP TOOLING, REFER TO THE INSTRUCTION SHEET FOR PROPER SETUP AND ADJUSTMENTS.

LOC	DIST	REVISIONS					
A	66	P	LTN	DESCRIPTION	DATE	OWN	APVD
		B		ECR-15-006929	04MAY2015	MR	JDG
		C		ECR-19-008914	06JUN2019	FZ	TB
		D		ECR-21-004551	18APR2021	TB	RK

-	1	-	1	-	2119641-1	FEED CAM, AIR FEED	248	
-	1	1	1	1	2119082-9	CAM, SNAIL, INSULATION ADJUSTMENT	244	
-	1	1	1	1	2079764-1	WASHER, WAVE SPRING, CREST-TO-CREST	243	
-	1	1	1	1	2119083-1	RETAINER, INSULATION DIAL	242	
-	1	1	1	1	7-18023-7	SCR, SKT HD CAP M3 X 4.0	241	
-	-	1	-	1	2119580-1	MECHANICAL FEED ASSEMBLY	239	
-	1	-	1	-	2844940-1	AIR FEED MODULE	238	
-	REF	REF	REF	REF	994970-2	COUNTER, MAGNETIC	164	
-	1	1	1	1	2844908-1	SCREW, LOCKING	99	
-	1	1	1	1	2844907-1	POST, LOCKING	98	
-	1	1	1	1	455888-6	SPACER, CRIMPER	82	
-	1	1	1	1	22278-8	SPRING, COMPRESSION	77	
-	1	1	1	1	854769-4	HOLDER, INS	74	
-	1	1	1	1	1803607-3	DOCUMENTATION PACKAGE	71	
-	1	1	1	1	2119740-1	TAG, IDENTIFICATION	67	
-	2	2	2	2	2168078-1	SCREW, DRIVE, RH, RoHS, 2 x .188	66	
-	1	1	1	1	2168083-2	SCR, SKT HD CAP, RoHS, M4 X 8.0	60	
-	1	1	1	1	5-18022-5	SCR, HEX HD CAP, M4 X 6.0	59	
-	1	1	1	1	21028-2	PIN, SLOTTED SPRING .062 X .250	58	
-	1	1	1	1	1338685-1	PAWL, FEED	56	
-	4	4	4	4	2168083-3	SCR, SKT HD CAP, RoHS, M4 X 12.0	54	
-	2	2	2	2	1-2168083-0	SCR, SKT HD CAP, RoHS, M4 X 10	53	
-	1	1	1	1	5018030-1	NUT, HEX, REG, RoHS, M3	52	
-	1	1	1	1	811242-5	BUMPER, HOLD DOWN	51	
-	1	1	1	1	690753-2	SPACER, TONKER	50	
-	1	2	1	2	18023-9	SCR, SKT HD CAP M4 X 6.0	49	
-	-	1	-	1	2119652-1	FEED CAM, PRE FEED	48	
-	-	1	-	1	2119653-1	FEED CAM, POST FEED	47	
-	1	1	1	1	1803583-9	APPLICATOR BASIC ASSEMBLY, SF	46	
-	1	1	1	1	1803515-1	RAM ASSEMBLY, SF ATLANTIC	44	
-	1	1	1	1	1803602-1	SCR, BHSC, RoHS (M8 X 25)	41	
-	1	1	1	1	3-1752356-3	SUPPORT, TERMINAL	34	
-	2	2	2	2	2079383-5	SCR, BHSC, RoHS (M4 X 20)	33	
-	2	2	2	2	2-2844962-6	SPACER, CYLINDRICAL, STRIP GUIDE	30	
-	1	1	1	1	2844992-1	ASSEMBLY, STRIP GUIDE	29	
-	1	1	1	1	455888-3	SPACER, CRIMPER	28	
-	1	1	1	1	1320928-2	STRIP GUIDE	24	
-	1	1	1	1	2168083-2	SCR, SKT HD CAP, RoHS, M4 X 8.0	21	
-	2	2	2	2	1-18028-2	WASHER, FLAT, REG M4	20	
-	1	1	1	1	2119533-1	STRIPPER, SIDE FEED	19	
-	1	1	1	1	2119806-1	INSERT, SHEAR	13	
-	1	1	1	1	3-22280-3	SPRING, COMPRESSION	12	
-	1	1	1	1	1-356885-4	STOP, SHEAR	11	
-	1	1	1	1	2119805-1	SHEAR HOLDER, FRONT	10	
-	1	1	1	1	1803095-6	FLOATING SHEAR, FRONT	9	
-	1	2	2	1	1	2-1803055-7	ANVIL, COMBINATION	8
-	-	-	-	-	-	-	7	
-	-	-	-	-	-	-	6	
-	1	1	1	1	1-2119780-4	DEPRESSOR, SHEAR	5	
-	1	1	1	1	4-238011-7	BLOCK, CRIMPER SPACER	4	
-	1	2	2	1	1	1-1803016-9	CRIMPER, INSULATION F	3
-	1	1	1	1	455888-5	SPACER, CRIMPER	2	
-	1	2	2	1	1	6-1633305-9	CRIMPER, WIRE PREMIUM	1
-	77	72	71	-2	-1	PART NO	ITEM NO	

ATLANTIC VERSION
Shown on sheets 1 of 4 & 2 of 4
(Pacific version shown on sheets 3 of 4 & 4 of 4)

DIMENSIONS:		TOLERANCES UNLESS OTHERWISE SPECIFIED:		OWN	CHK	DATE	NAME
mm	0 PLC ±.5	1 PLC ±0.5	2 PLC ±0.13	J. HOU	L. ZHANG	29 JAN 2015	TE Connectivity
	3 PLC ±0.013	4 PLC ±0.001	ANGLES ±.0001				Harrisburg, PA 17105-3608
MATERIAL	FINISH	WEIGHT	SCALE	APVD	U. GUO	29 JAN 2015	Ocean Side Feed Applicator
			1:2	PRODUCT SPEC			
				APPLICATION SPEC			
				SIZE	CAGE CODE	DRAWING NO	RESTRICTED TO
				A1	00779	2266669	
				Customer Accessible Production Drawing		SHEET 1 OF 4	REV D

LOC	DIST	REVISIONS					
A	66	P	LTN	DESCRIPTION	DATE	OWN	APVD
		-		SEE SHEET 1			

FEED TYPE MECHANICAL

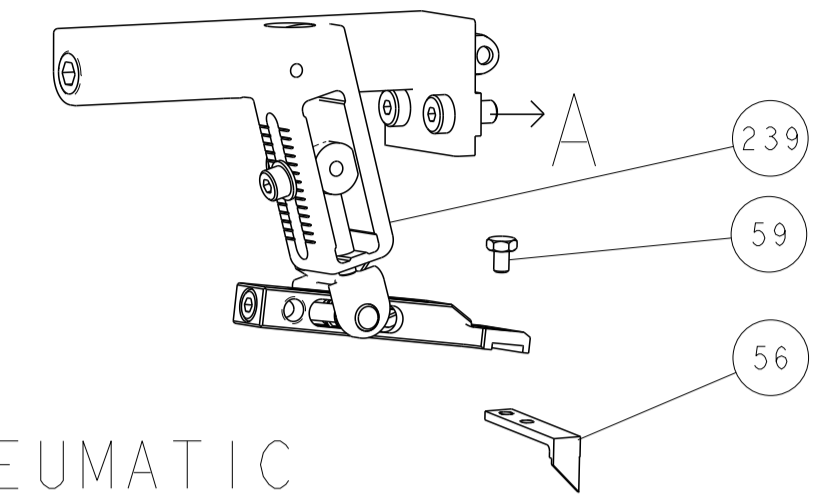

PNEUMATIC

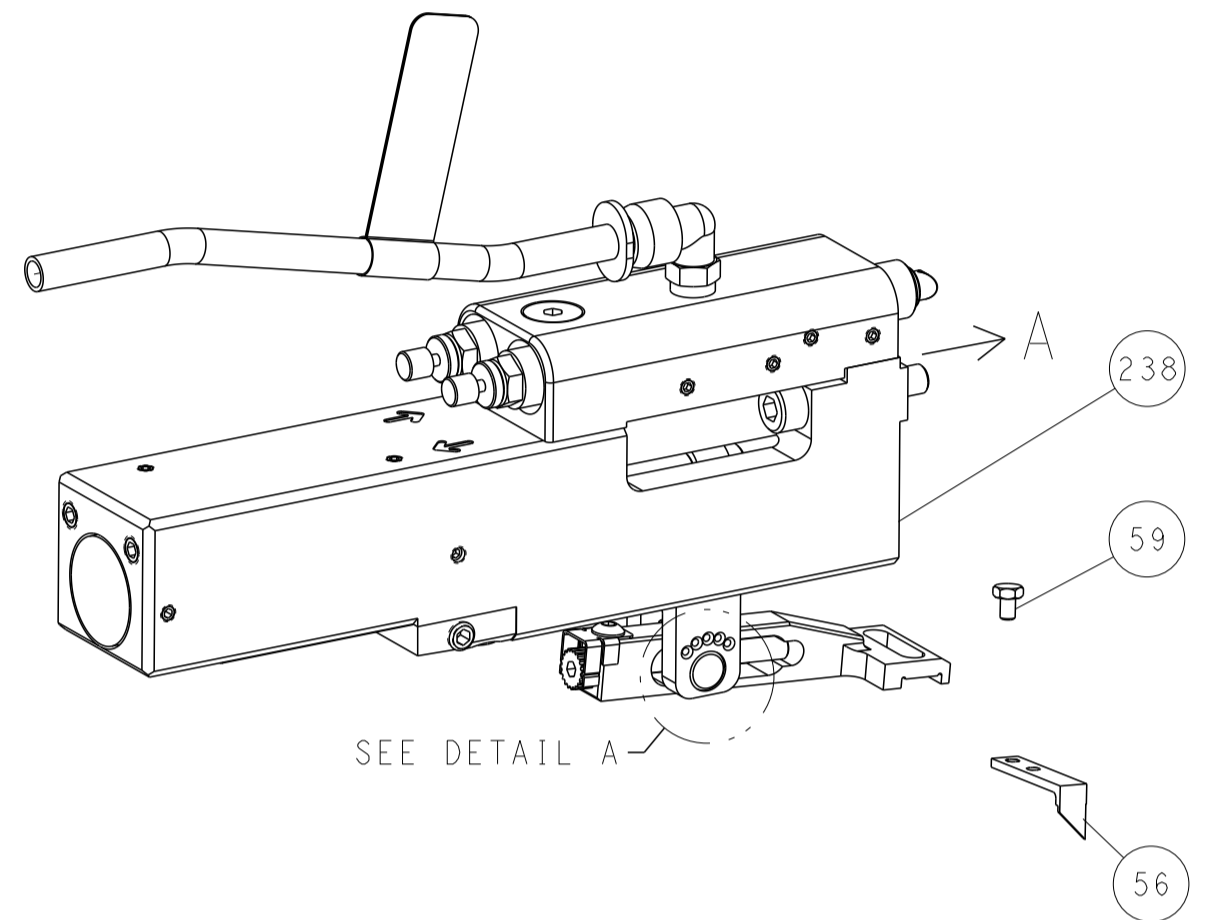

FEED SPRING SETTING POSITION (SHOWN FROM REAR SIDE)

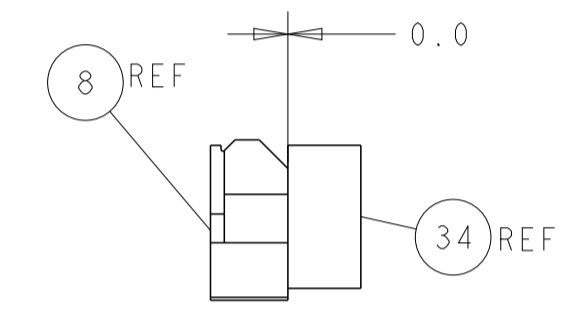
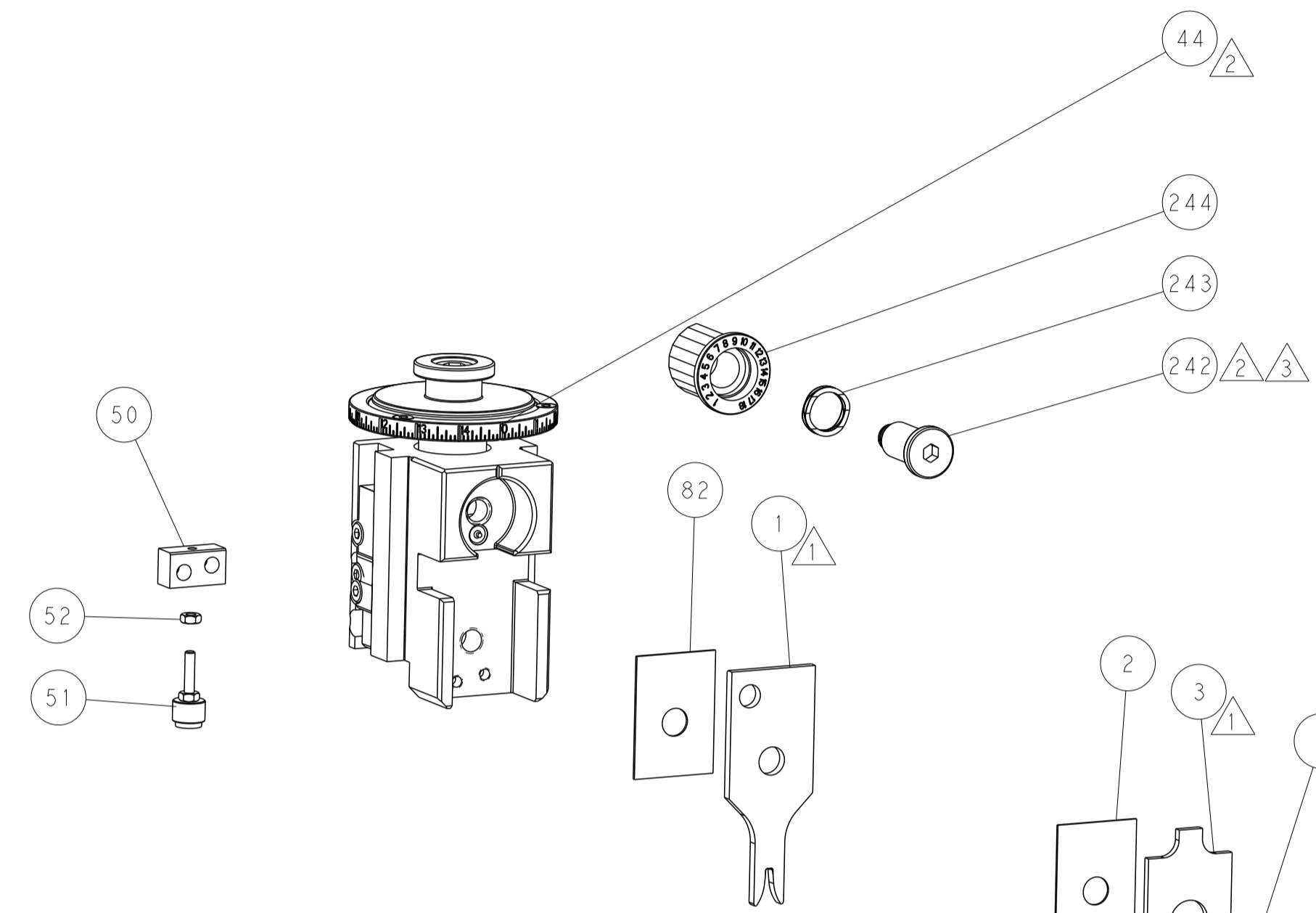
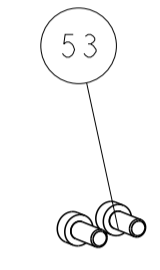

TERMINAL SUPPORT LOCATION

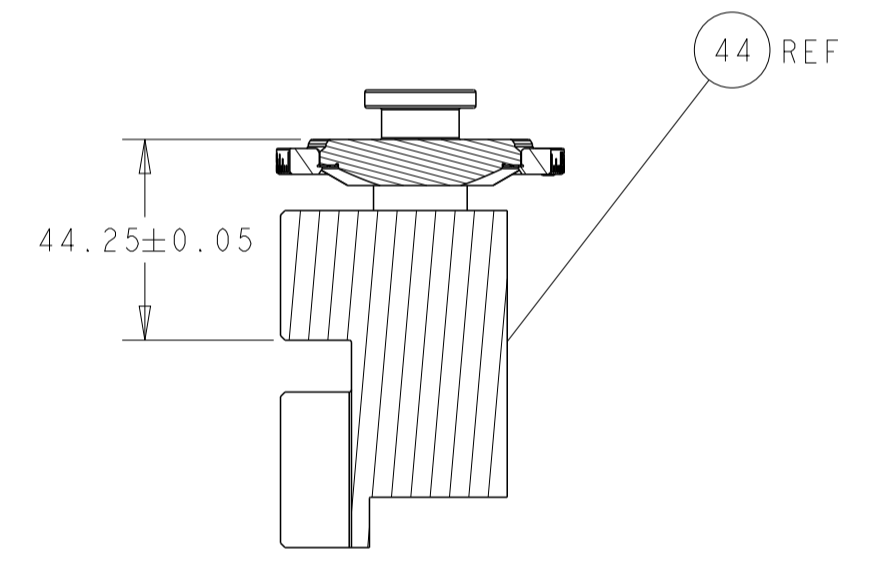

RAM SET-UP

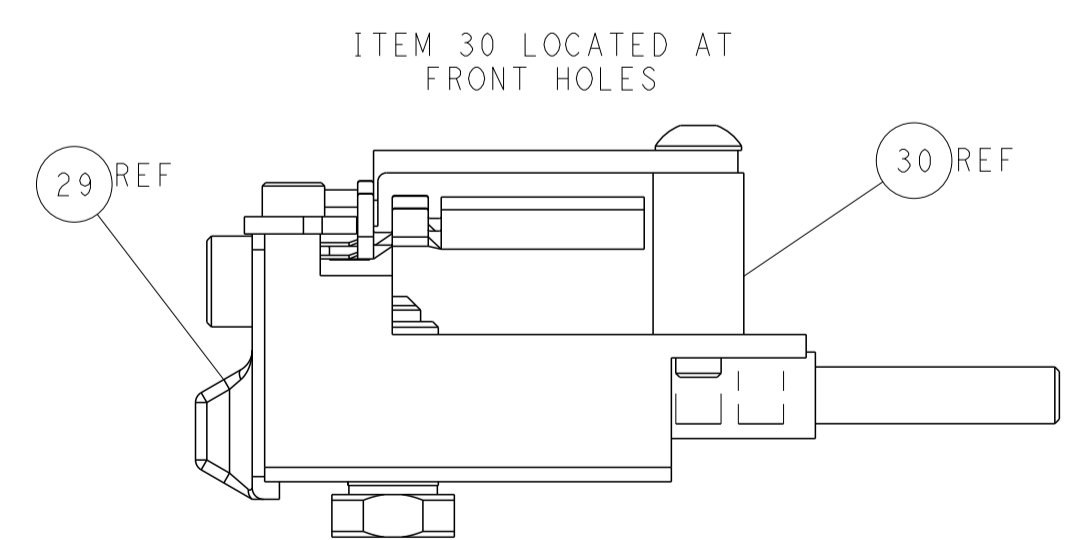
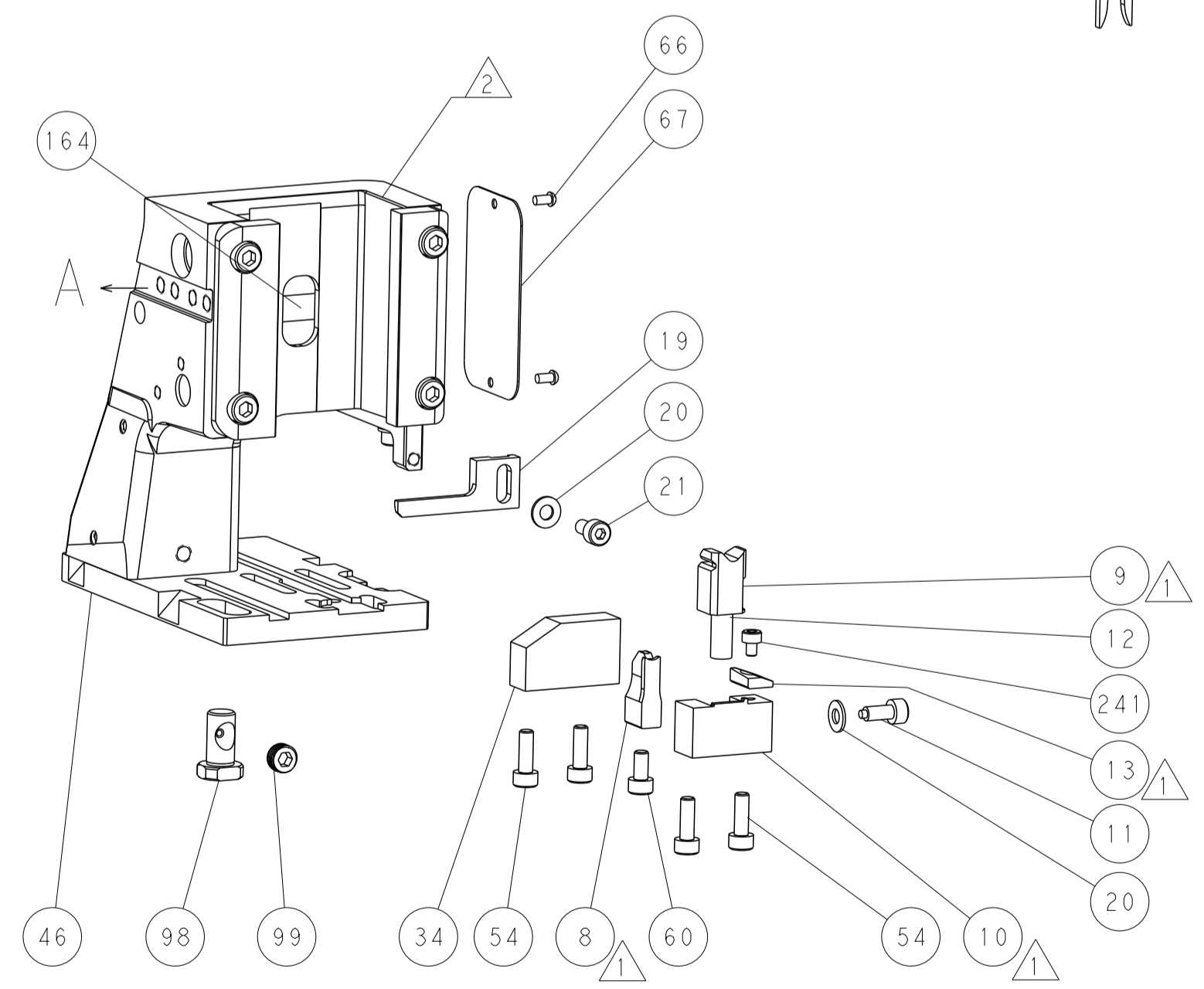
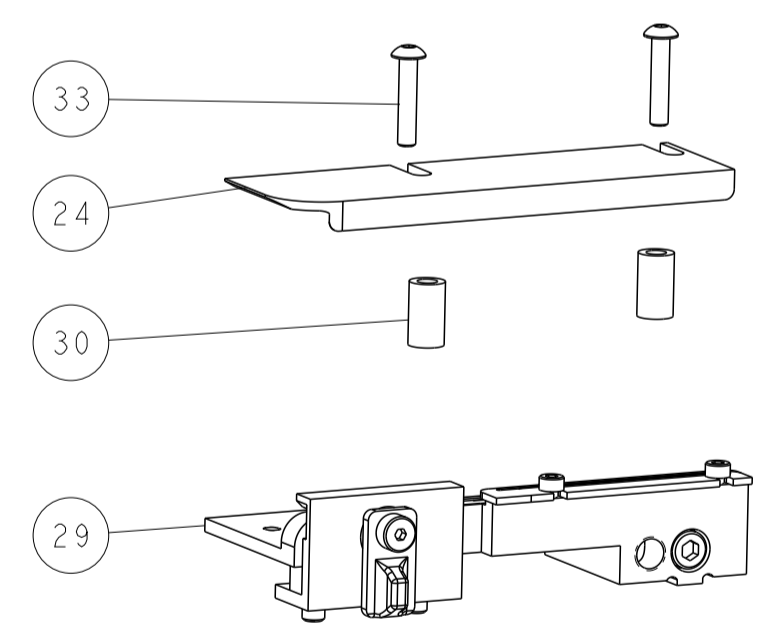

FEED TRACK POSITION GUIDE BY INSULATION BARREL

CAM POSITIONS

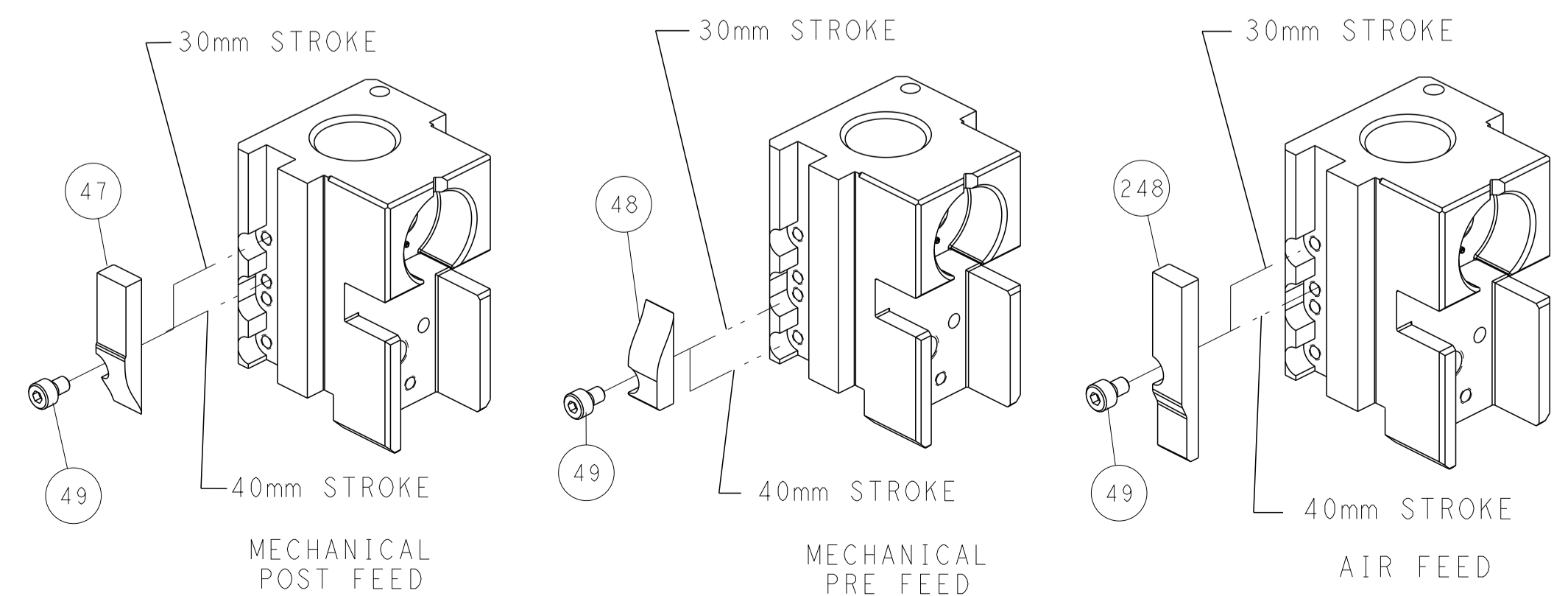

ATLANTIC VERSION
 Shown on sheets 1 of 4 & 2 of 4
 (Pacific version shown on sheets 3 of 4 & 4 of 4)

DIMENSIONS: mm 		TOLERANCES UNLESS OTHERWISE SPECIFIED: 0 PLC ±.5 1 PLC ±0.5 2 PLC ±0.13 3 PLC ±0.013 4 PLC ±0.001 ANGLES ±.0001 FINISH		DWN J. HOU 29JAN2015 CHK L. ZHANG 29JAN2015 APVD H. GUO 29JAN2015 NAME Ocean Side Feed Applicator SIZE CAGE CODE DRAWING NO RESTRICTED TO A1 00779 C=2266669 Customer Accessible Production Drawing SCALE 1:2 SHEET 2 OF 4 REV D	
MATERIAL:		WEIGHT:		TE Connectivity Harrisburg, PA 17105-3608	

PART NUMBER	REVISION	DESCRIPTION	FEED TYPE
2-2266669-1	C	FINE CRIMP HEIGHT ADJUST	MECHANICAL
2-2266669-2	D	FINE CRIMP HEIGHT ADJUST	PNEUMATIC
7-2266669-7	A	CRIMP TOOLING KIT	-

PACIFIC VERSION TERMINATOR
INTERFACE ADAPTER



APPLICATOR DATA		
CRIMP	SIZE	TYPE
WIRE	2.29 mm [.090]	F
INSUL	5.08 mm [.200]	F
APPLICATOR INSTRUCTIONS 408-35042		

TERMINAL DATA: TE TERMINAL		TE CRIMP SPECIFICATION	
TERMINAL NAME: UNIVERSAL MATE-N-LOCK II			
WIRE STRIP LENGTH 4.00-4.76 mm [.157-.187 IN]		INSULATION DIAMETER RANGE Ø3.30-5.08 mm [.130-.200 IN]	
TERMINAL APPLICATION SPECIFICATION	114-1043	-	-
TERMINALS APPLIED			
TE TERMINAL	TE TERMINAL	TE TERMINAL	TE TERMINAL
770005-1	770005-9	770006-3	770194-1
770005-3	1-770005-0	770006-4	770194-9
770005-8	1-770005-1	1-77000-0	1-770194-0

WIRE SIZE	CRIMP HEIGHT mm [INCH]	CRIMP HEIGHT REFERENCE SETTING
14 AWG	1.75 +/- 0.05 [.069 +/- .002]	4.6
16 AWG	1.50 +/- 0.05 [.059 +/- .002]	7.4
18 AWG	1.32 +/- 0.05 [.052 +/- .002]	9.3
20 AWG	1.19 +/- 0.05 [.047 +/- .002]	10.6

- 1 RECOMMENDED SPARE PARTS
- 2 REFER TO SUPPLIED INSTRUCTION SHEET FOR CLEANING, LUBRICATION AND STORAGE OF APPLICATOR.
- 3 APPLY PART NUMBER 2-23419-6 LOCTITE TO THREADS OF ITEM 242.
- 4 CRIMP HEIGHT REFERENCE SETTING WAS THE SETTING USED WHEN THE APPLICATOR WAS QUALIFIED AT THE FACTORY. ADJUSTMENT MAY BE NECESSARY WHEN RUNNING APPLICATOR IN THE FIELD.
- 5. UNLESS SPECIFIED OTHERWISE TORQUE VALUES SHALL BE USED PER DOCUMENT, 101-35000.

***WARNING**
ON INSTALLATION, SET WIRE DISC TO CRIMP HEIGHT REFERENCE SETTING FOR LARGEST WIRE SIZE. CRIMP HEIGHT REFERENCE SETTINGS GREATER THAN THE VALUE SHOWN MAY CAUSE DAMAGE TO THE CRIMP TOOLING, REFER TO THE INSTRUCTION SHEET FOR PROPER SETUP AND ADJUSTMENTS.

PACIFIC VERSION
Shown on sheets 3 of 4 & 4 of 4
(Atlantic version shown on sheets 1 of 4 & 2 of 4)

LOC	DIST	REV	DATE	BY	APPV
A	66	-	-	-	-

REV	DATE	BY	APPV	DESCRIPTION	ITEM NO
-	1	1	2119082-9	CAM, SNAIL, INSULATION ADJUSTMENT	244
-	1	1	2079764-1	WASHER, WAVE SPRING, CREST-TO-CREST	243
3	-	1	2119083-1	RETAINER, INSULATION DIAL	242
-	1	1	7-18023-7	SCR, SKT HD CAP M3 X 4.0	241
-	-	1	2119580-1	MECHANICAL FEED ASSEMBLY	239
-	1	-	2844940-1	AIR FEED MODULE	238
-	REF	REF	994970-2	COUNTER, MAGNETIC	164
-	1	-	2119641-2	FEED CAM, AIR FEED	151
-	1	1	2168083-8	SCR, SKT HD CAP, RoHS, M4 X 16	144
-	4	4	2168083-9	SCR, SKT HD CAP, RoHS, M4 X 20	143
-	-	1	2119653-2	FEED CAM, POST FEED	142
-	1	1	1-1803583-0	APPLICATOR BASIC ASSEMBLY, SF	141
-	1	1	1803516-1	RAM ASSEMBLY, SF PACIFIC	140
-	1	1	2844908-1	SCREW, LOCKING	99
-	1	1	2844907-1	POST, LOCKING	98
-	1	1	455888-6	SPACER, CRIMPER	82
-	1	1	22278-8	SPRING, COMPRESSION	77
-	1	1	854769-4	HOLDER, INS	74
-	1	1	1803607-3	DOCUMENTATION PACKAGE	71
-	1	1	2119740-1	TAG, IDENTIFICATION	67
-	2	2	2168078-1	SCREW, DRIVE, RH, RoHS, 2 x .188	66
-	1	1	5-18022-5	SCR, HEX HD CAP, M4 X 6.0	59
-	1	1	21028-2	PIN, SLOTTED SPRING .062 X .250	58
-	1	1	1338685-1	PAWL, FEED	56
-	2	2	1-2168083-0	SCR, SKT HD CAP, RoHS, M4 X 10	53
-	1	1	5018030-1	NUT, HEX, REG, RoHS, M3	52
-	1	1	811242-5	BUMPER, HOLD DOWN	51
-	1	1	690753-2	SPACER, TONKER	50
-	1	2	18023-9	SCR, SKT HD CAP M4 X 6.0	49
-	-	1	2119652-1	FEED CAM, PRE FEED	48
-	1	1	1803602-1	SCR, BHSC, RoHS (M8 X 25)	41
-	1	1	3-1752356-3	SUPPORT, TERMINAL	34
-	2	2	2079383-5	SCR, BHSC, RoHS (M4 X 20)	33
-	2	2	2-2844962-6	SPACER, CYLINDRICAL, STRIP GUIDE	30
-	1	1	2844992-1	ASSEMBLY, STRIP GUIDE	29
-	1	1	455888-3	SPACER, CRIMPER	28
-	1	1	1320928-2	STRIP GUIDE	24
-	1	1	2168083-2	SCR, SKT HD CAP, RoHS, M4 X 8.0	21
-	2	2	1-18028-2	WASHER, FLAT, REG M4	20
-	1	1	2119533-1	STRIPPER, SIDE FEED	19
1	1	1	2119806-1	INSERT, SHEAR	13
-	1	1	3-22280-3	SPRING, COMPRESSION	12
-	1	1	1-356885-4	STOP, SHEAR	11
-	1	1	2119805-1	SHEAR HOLDER, FRONT	10
1	1	1	1803095-6	FLOATING SHEAR, FRONT	9
1	1	1	2-1803055-7	ANVIL, COMBINATION	8
-	-	-	-	-	7
-	-	-	-	-	6
-	1	1	1-2119780-4	DEPRESSOR, SHEAR	5
-	1	1	4-238011-7	BLOCK, CRIMPER SPACER	4
1	1	1	1-1803016-9	CRIMPER, INSULATION F	3
-	1	1	455888-5	SPACER, CRIMPER	2
1	1	1	6-1633305-9	CRIMPER, WIRE PREMIUM	1

<small>THIS DRAWING IS UNPUBLISHED. RELEASED FOR PUBLICATION. BY TYCO ELECTRONICS CORPORATION. ALL RIGHTS RESERVED. COPYRIGHT 2008.</small>		DWN: J. HOU 29JAN2015 CHK: L. ZHANG 29JAN2015 APVD: J. GUO 29JAN2015	NAME: TE Connectivity Harrisburg, PA 17105-3608
DIMENSIONS: mm 0 PLC ±.5 1 PLC ±0.5 2 PLC ±0.13 3 PLC ±0.013 4 PLC ±0.001 ANGLES ±.001 FINISH	TOLERANCES UNLESS OTHERWISE SPECIFIED:	PRODUCT SPEC: - APPLICATION SPEC: - WEIGHT: -	SIZE: A1 CAGE CODE: 00779 DRAWING NO: 2266669 SCALE: 1:2 SHEET: 3 OF 4 REV: D
MATERIAL: -		Customer Accessible Production Drawing	

LOC		DIST		REVISIONS			
A	66	P	LTN	DESCRIPTION	DATE	DWN	APVD
-	-	-	-	SEE SHEET 1	-	-	-

FEED TYPE MECHANICAL

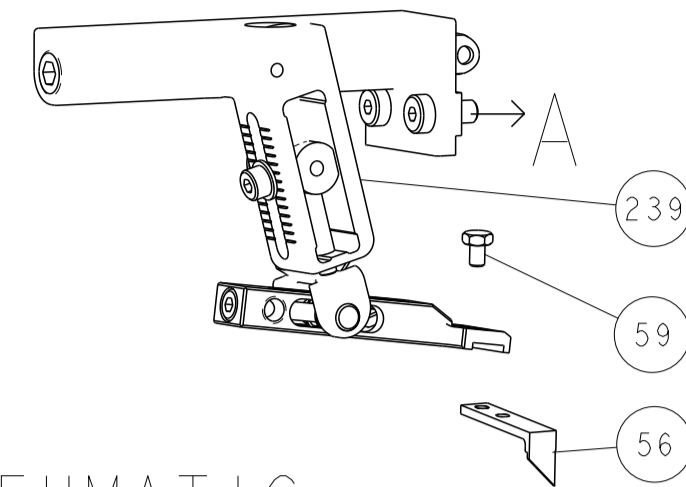

PNEUMATIC

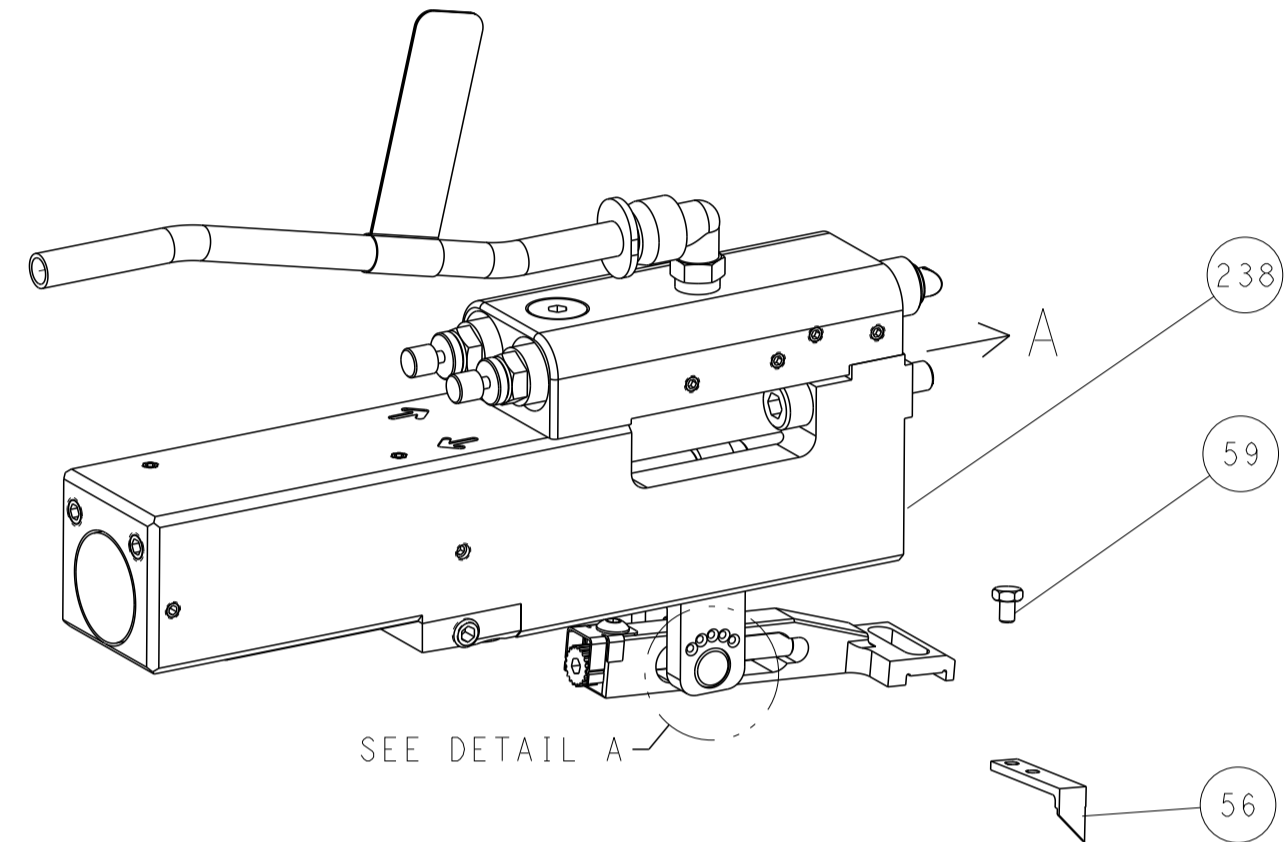

FEED SPRING SETTING POSITION (SHOWN FROM REAR SIDE)

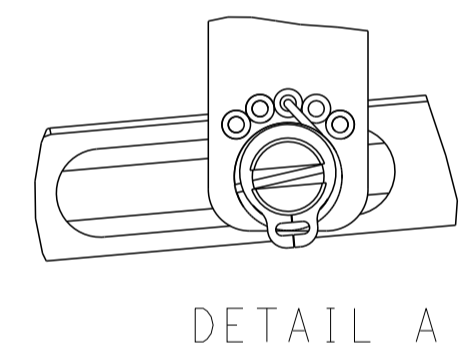

DETAIL A

CAM POSITIONS

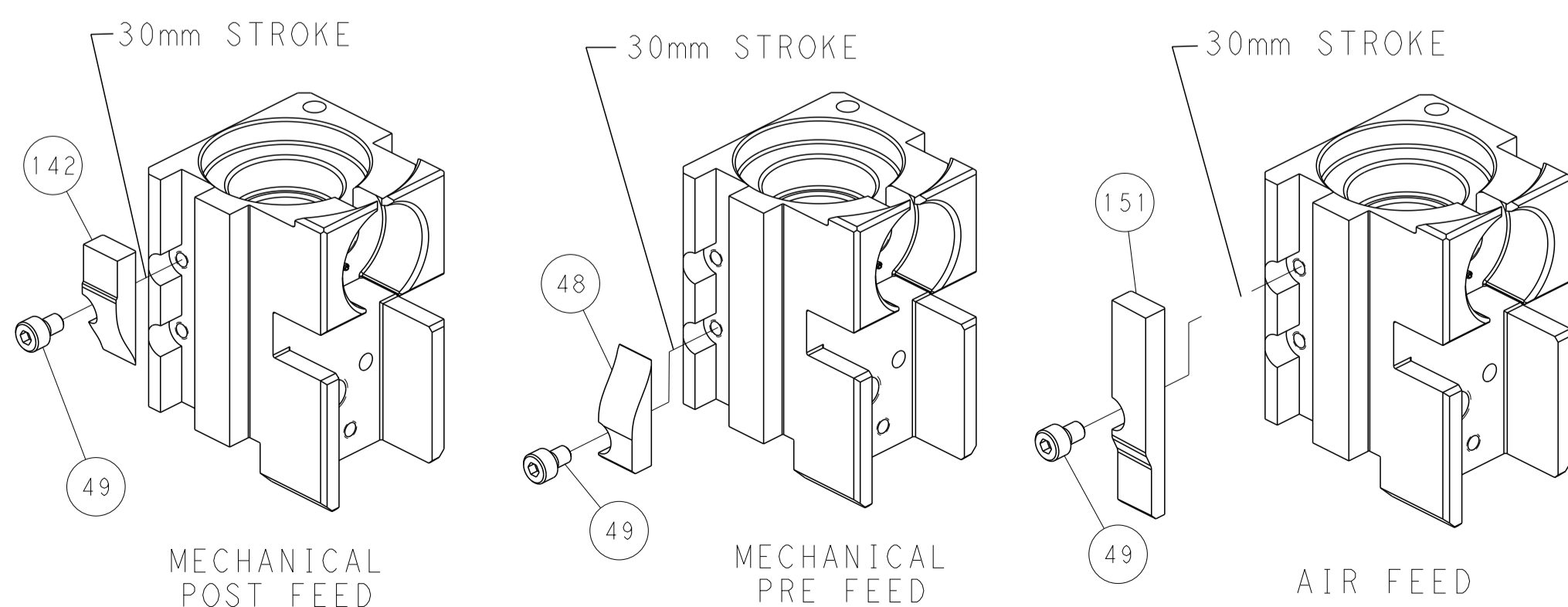

MECHANICAL POST FEED

MECHANICAL PRE FEED

AIR FEED

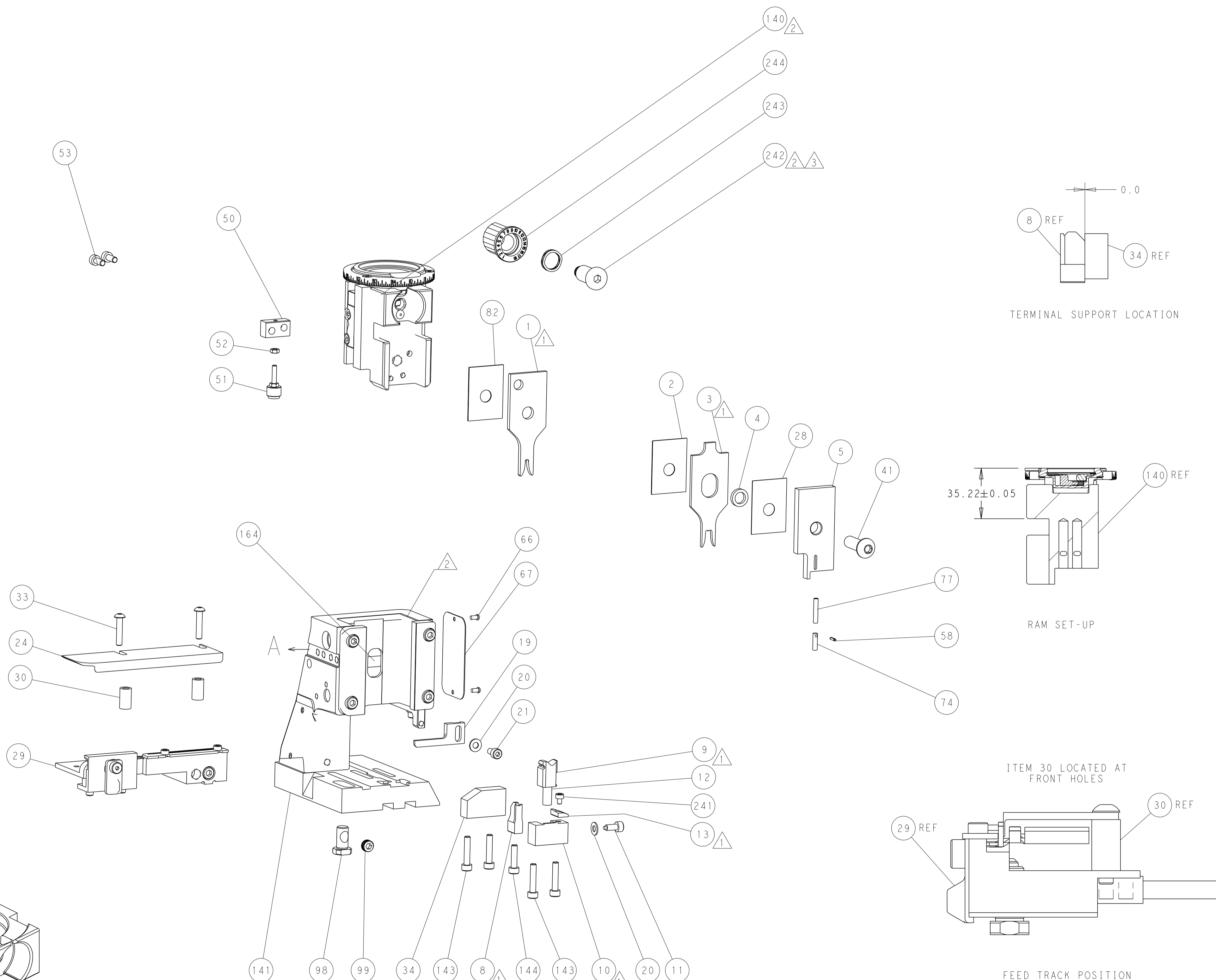

TERMINAL SUPPORT LOCATION

RAM SET-UP

ITEM 30 LOCATED AT FRONT HOLES

FEED TRACK POSITION GUIDE BY INSULATION BARREL

PACIFIC VERSION
 Shown on sheets 3 of 4 & 4 of 4
 (Atlantic version shown on sheets 1 of 4 & 2 of 4)

DIMENSIONS:		TOLERANCES UNLESS OTHERWISE SPECIFIED:		DWN 12MAR2014		TE Connectivity	
mm	0 PLC ±0.5	1 PLC ±0.5	2 PLC ±0.13	3 PLC ±0.013	4 PLC ±0.001	APVD 12MAR2014	Harrisburg, PA 17105-3608
MATERIAL:		FINISH:		PRODUCT SPEC		NAME	
				APPLICATION SPEC		Ocean Side Feed Applicator	
				WEIGHT		RESTRICTED TO	
				A1 00779 ©=2266669		SIZE CAGE CODE DRAWING NO	
				Customer Accessible Production Drawing		SCALE 1:2 SHEET 4 OF 4 REV D	

Mouser Electronics

Authorized Distributor

Click to View Pricing, Inventory, Delivery & Lifecycle Information:

[TE Connectivity:](#)

[2266669-1](#)