

PART NUMBER	REVISION	DESCRIPTION	FEED TYPE
2266607-1	B	FINE CRIMP HEIGHT ADJUST	MECHANICAL
2266607-2	B	FINE CRIMP HEIGHT ADJUST	PNEUMATIC
7-2266607-1	B	MECHANICAL AND CRIMP TOOLING KIT	MECHANICAL
7-2266607-2	B	PNEUMATIC AND CRIMP TOOLING KIT	PNEUMATIC
7-2266607-7	A	CRIMP TOOLING KIT	-

ATLANTIC VERSION TERMINATOR INTERFACE ADAPTER



APPLICATOR DATA		
CRIMP	SIZE	TYPE
WIRE	1.85 mm [.073]	F
INSUL	2.54 mm [.100]	F

APPLICATOR INSTRUCTIONS 408-35042

TERMINAL DATA: DELPHI TERMINAL DELPHI CRIMP SPECIFICATION			
TERMINAL NAME: CTS 2.8MM ASSEMBLY			
WIRE STRIP LENGTH	INSULATION DIAMETER RANGE		
3.62-4.38 mm [.143-.172 IN]	Ø1.40-2.10 mm [.055-.083 IN]		
TERMINAL APPLICATION SPECIFICATION	15457850 Rev 01		
TERMINALS APPLIED			
TE TERMINAL	DELPHI TERMINAL	TE TERMINAL	DELPHI TERMINAL
2113630-1	15457848		

WIRE SIZE	CRIMP HEIGHT mm [INCH]	CRIMP HEIGHT REFERENCE SETTING
1.00mm2	1.40 +/- 0.05 [.055 +/- .002]	7.4
0.75mm2	1.35 +/- 0.05 [.053 +/- .002]	7.9
0.50mm2	1.25 +/- 0.05 [.049 +/- .002]	8.9

- 1 RECOMMENDED SPARE PARTS
- 2 REFER TO SUPPLIED INSTRUCTION SHEET FOR CLEANING, LUBRICATION AND STORAGE OF APPLICATOR.
- 3 APPLY PART NUMBER 2-23419-6 LOCTITE TO THREADS OF ITEM 242.
- 4 CRIMP HEIGHT REFERENCE SETTING WAS THE SETTING USED WHEN THE APPLICATOR WAS QUALIFIED AT THE FACTORY. ADJUSTMENT MAY BE NECESSARY WHEN RUNNING APPLICATOR IN THE FIELD.
- 5. UNLESS SPECIFIED OTHERWISE TORQUE VALUES SHALL BE USED PER DOCUMENT, 101-35000

***WARNING**
 ON INSTALLATION, SET WIRE DISC TO CRIMP HEIGHT REFERENCE SETTING FOR LARGEST WIRE SIZE. CRIMP HEIGHT REFERENCE SETTINGS GREATER THAN THE VALUE SHOWN MAY CAUSE DAMAGE TO THE CRIMP TOOLING. REFER TO THE INSTRUCTION SHEET FOR PROPER SETUP AND ADJUSTMENTS.

ATLANTIC VERSION
 Shown on sheets 1 of 4 & 2 of 4
 (Pacific version shown on sheets 3 of 4 & 4 of 4)

LOC	DIST	REVISIONS					
		P	LTN	DESCRIPTION	DATE	OWN	APVD
A	66	A		RELEASED	24FEB2015	MR	TE
		B		ECR-21-004463	15APR2021	TB	RR

-	1	-	1	-	2119641-1	FEED CAM, AIR FEED	248	
-	1	1	1	1	2119082-4	CAM, SNAIL, INSULATION ADJUSTMENT	244	
-	1	1	1	1	2079764-1	WASHER, WAVE SPRING, CREST-TO-CREST	243	
3	-	1	1	1	2119083-1	RETAINER, INSULATION DIAL	242	
-	1	1	1	1	7-18023-7	SCR, SKT HD CAP M3 X 4.0	241	
-	-	1	-	1	2119580-1	MECHANICAL FEED ASSEMBLY	239	
-	1	-	1	-	2844940-1	AIR FEED MODULE	238	
-	REF	REF	REF	REF	994970-2	COUNTER, MAGNETIC	164	
-	1	1	1	1	2844908-1	SCREW, LOCKING	99	
-	1	1	1	1	2844907-1	POST, LOCKING	98	
-	1	1	1	1	455888-7	SPACER, CRIMPER	82	
-	1	1	1	1	1803607-3	DOCUMENTATION PACKAGE	71	
-	1	1	1	1	2119740-1	TAG, IDENTIFICATION	67	
-	2	2	2	2	2168078-1	SCREW, DRIVE, RH, RoHS, 2 x .188	66	
-	1	1	1	1	2168083-2	SCR, SKT HD CAP, RoHS, M4 X 8.0	60	
-	1	1	1	1	5-18022-5	SCR, HEX HD CAP, M4 X 6.0	59	
-	1	1	1	1	1338685-1	PAWL, FEED	56	
-	4	4	4	4	2168083-3	SCR, SKT HD CAP, RoHS, M4 X 12.0	54	
-	2	2	2	2	1-2168083-0	SCR, SKT HD CAP, RoHS, M4 X 10	53	
-	1	1	1	1	5018030-1	NUT, HEX, REG, RoHS, M3	52	
-	1	1	1	1	811242-5	BUMPER, HOLD DOWN	51	
-	1	1	1	1	690753-2	SPACER, TONKER	50	
-	1	2	1	2	18023-9	SCR, SKT HD CAP M4 X 6.0	49	
-	-	1	-	1	2119652-1	FEED CAM, PRE FEED	48	
-	-	1	-	1	2119653-1	FEED CAM, POST FEED	47	
-	1	1	1	1	1803583-9	APPLICATOR BASIC ASSEMBLY, SF	46	
-	1	1	1	1	1803515-1	RAM ASSEMBLY, SF ATLANTIC	44	
-	1	1	1	1	1803602-1	SCR, BHSC, RoHS (M8 X 25)	41	
-	1	1	1	1	1-1752356-7	SUPPORT, TERMINAL	34	
-	2	2	2	2	2079383-5	SCR, BHSC, RoHS (M4 X 20)	33	
-	2	2	2	2	2-2844962-6	SPACER, CYLINDRICAL, STRIP GUIDE	30	
-	1	1	1	1	2844992-1	ASSEMBLY, STRIP GUIDE	29	
-	1	1	1	1	455888-3	SPACER, CRIMPER	28	
-	1	1	1	1	1320928-2	STRIP GUIDE	24	
-	1	1	1	1	2168083-2	SCR, SKT HD CAP, RoHS, M4 X 8.0	21	
-	2	2	2	2	1-18028-2	WASHER, FLAT, REG M4	20	
-	1	1	1	1	2119533-1	STRIPPER, SIDE FEED	19	
1	-	1	1	1	2119806-1	INSERT, SHEAR	13	
-	1	1	1	1	3-22280-3	SPRING, COMPRESSION	12	
-	1	1	1	1	1-356885-4	STOP, SHEAR	11	
-	1	1	1	1	2119805-1	SHEAR HOLDER, FRONT	10	
1	-	1	1	1	1803095-6	FLOATING SHEAR, FRONT	9	
1	1	2	2	1	1	7-1803054-4	ANVIL, COMBINATION	8
-	-	-	-	-	-	-	7	
-	-	-	-	-	-	-	6	
-	1	1	1	1	2119757-8	DEPRESSOR, SHEAR	5	
-	1	1	1	1	238011-4	BLOCK, CRIMPER SPACER	4	
1	1	2	2	1	1	7-1633962-9	CRIMPER, INSULATION F PREMIUM	3
-	1	1	1	1	455888-3	SPACER, CRIMPER	2	
1	1	2	2	1	1	4-1633860-4	CRIMPER, WIRE	1
-	77	-72	-71	-2	-1	PART NO	ITEM NO	

DIMENSIONS:		TOLERANCES UNLESS OTHERWISE SPECIFIED:		MATERIAL:		FINISH:	
mm	0 PLC ±	1 PLC ±	2 PLC ±	3 PLC ±	4 PLC ±	ANGLES ±	

OWN	H. HUANG	04FEB2015	
CHK	M. RILEY	04FEB2015	
APVD	T. ELBIN	04FEB2015	
NAME	Ocean Side Feed Applicator		
SIZE	CAGE CODE	DRAWING NO	RESTRICTED TO
A1	00779	2266607	
Customer Accessible Production Drawing		SCALE	1:2
		SHEET	1 of 4
		REV	B

LOC		DIST		REVISIONS			
A	66	P	LYN	DESCRIPTION	DATE	OWN	APVD
		-		SEE SHEET 1			

FEED TYPE MECHANICAL

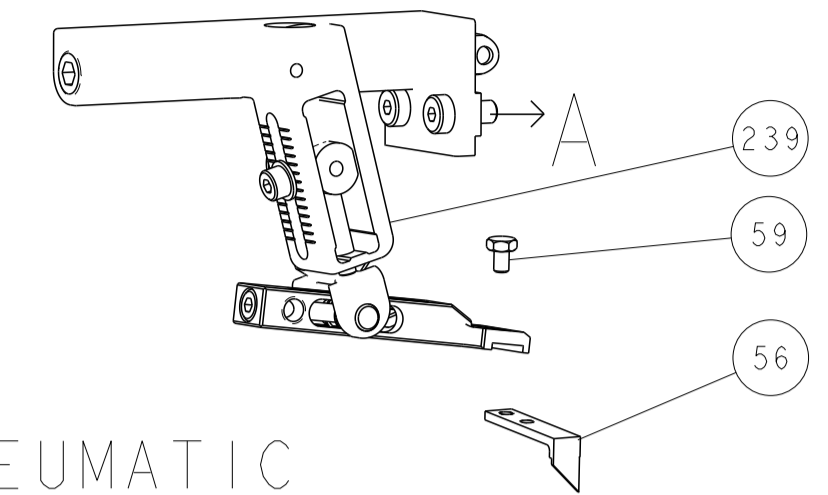

PNEUMATIC

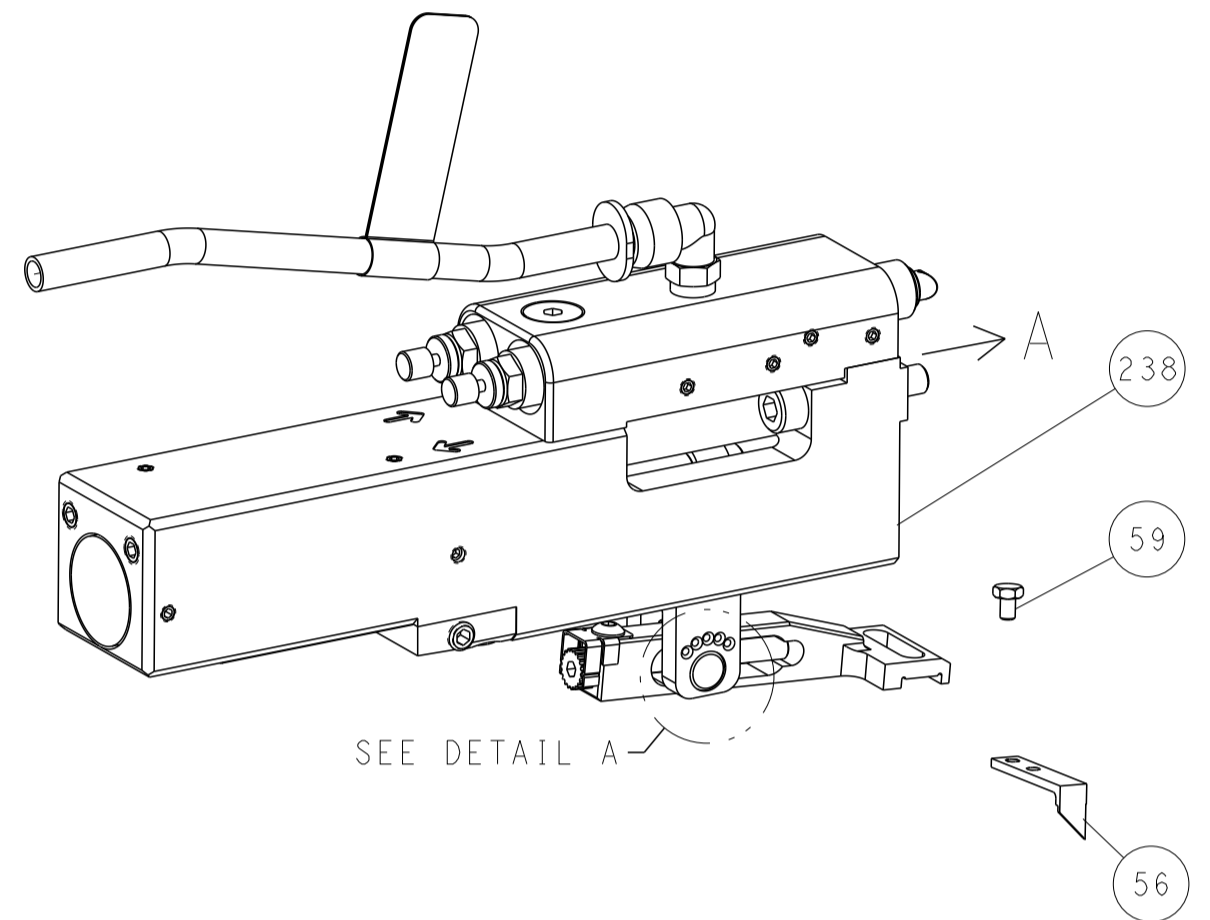

FEED SPRING SETTING POSITION (SHOWN FROM REAR SIDE)

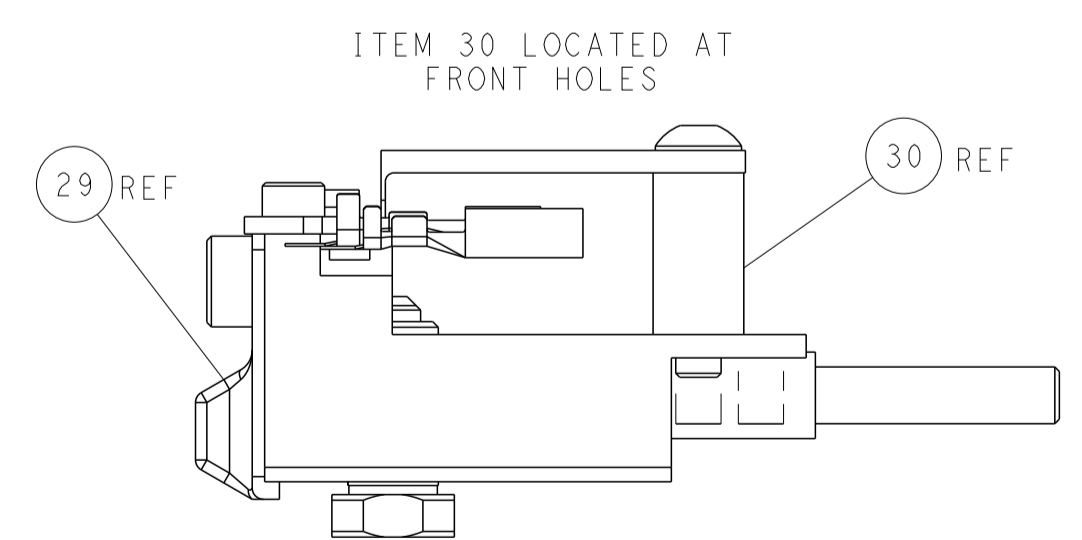
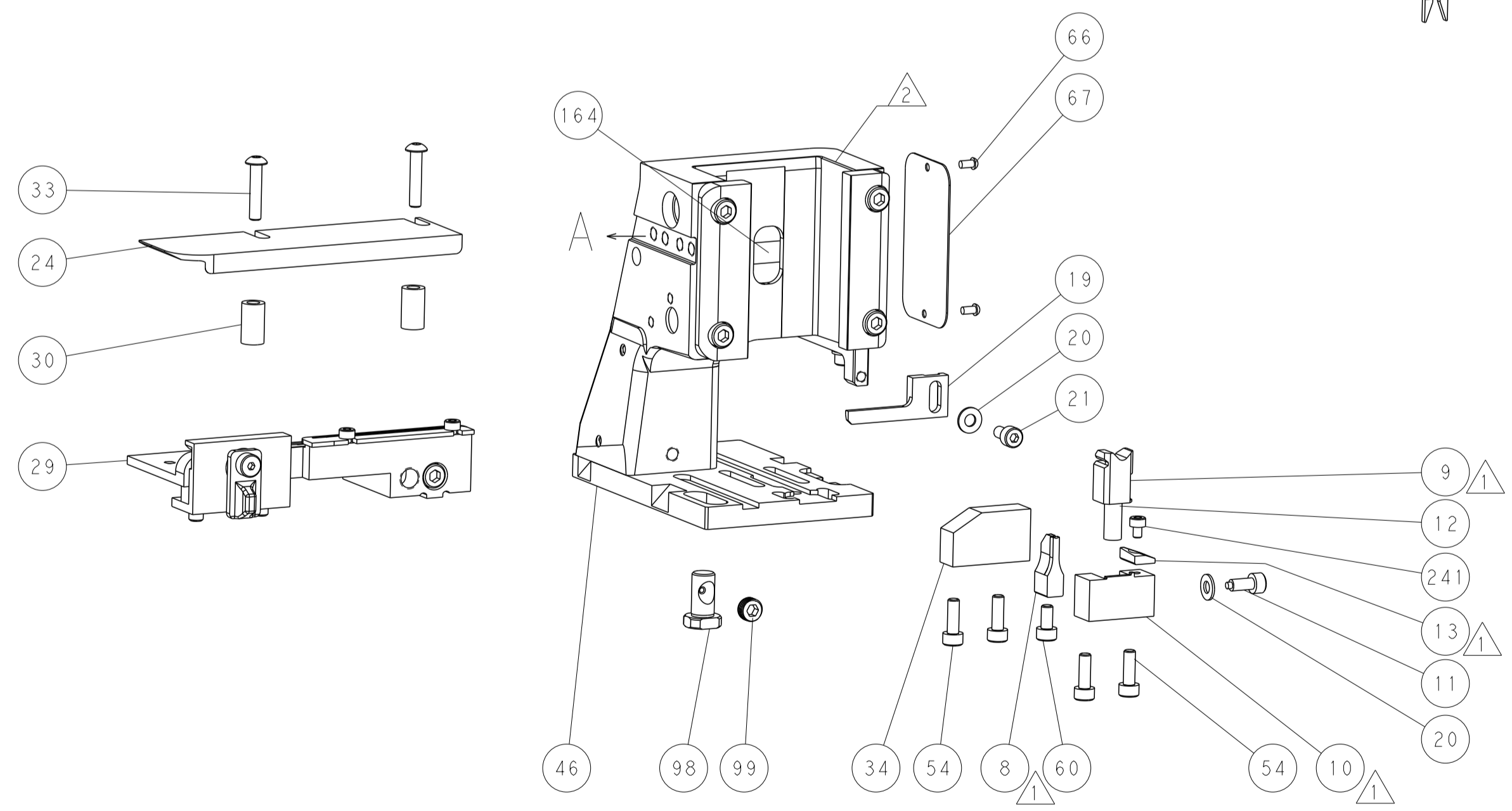
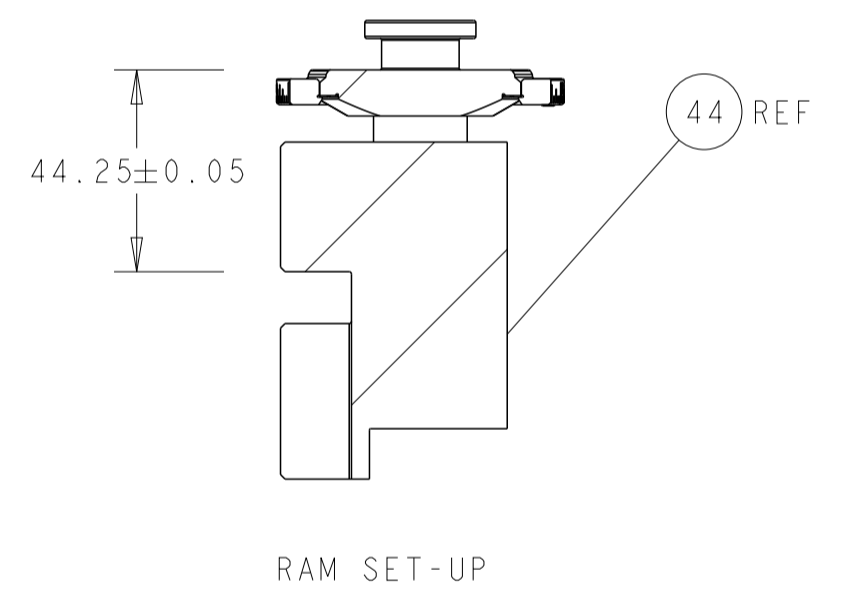
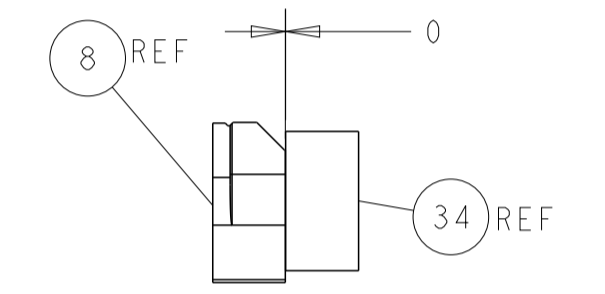
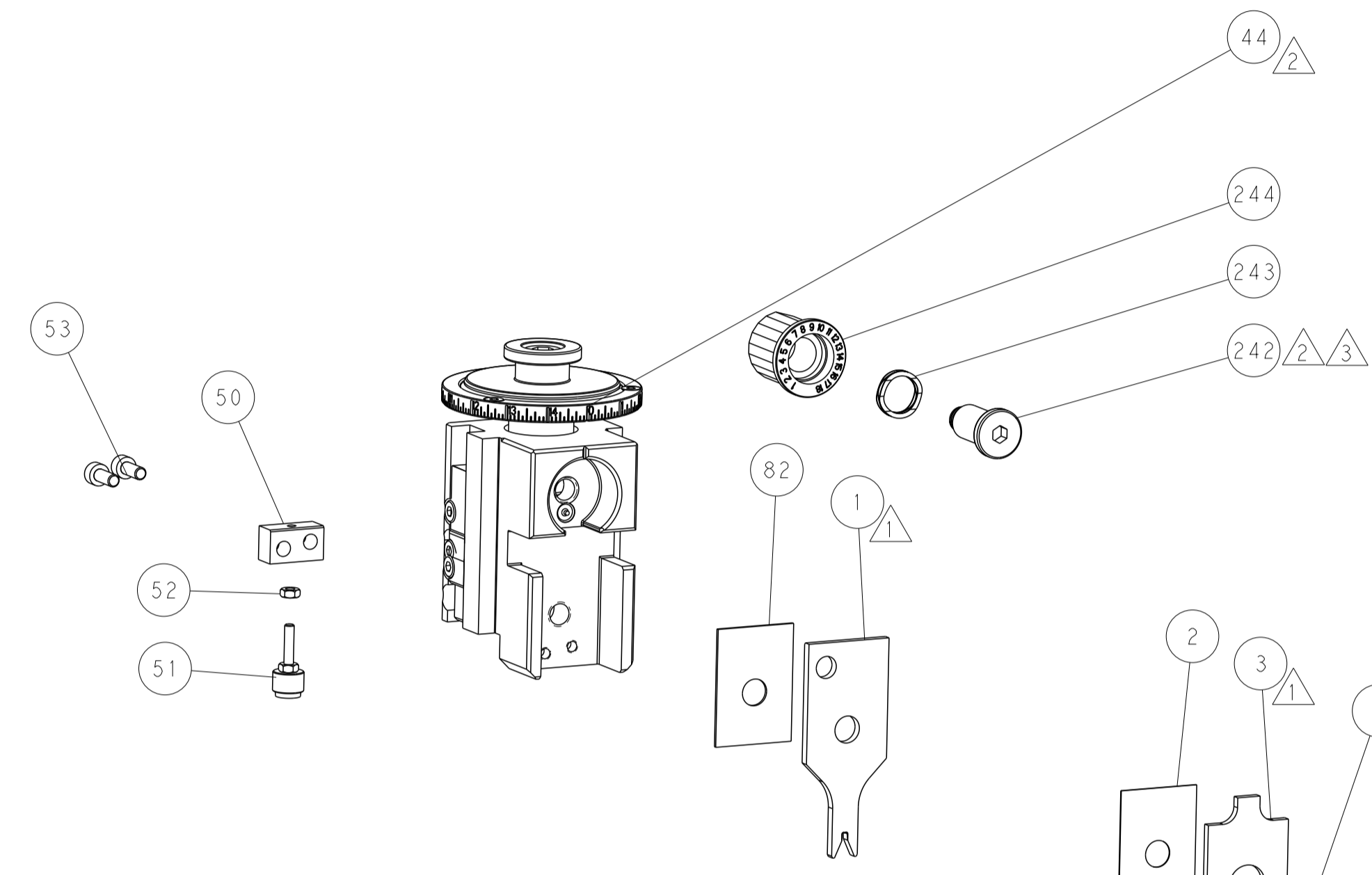
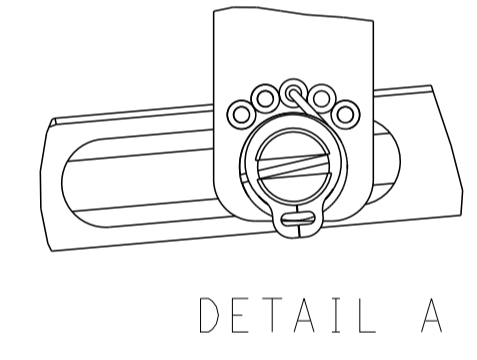

CAM POSITIONS

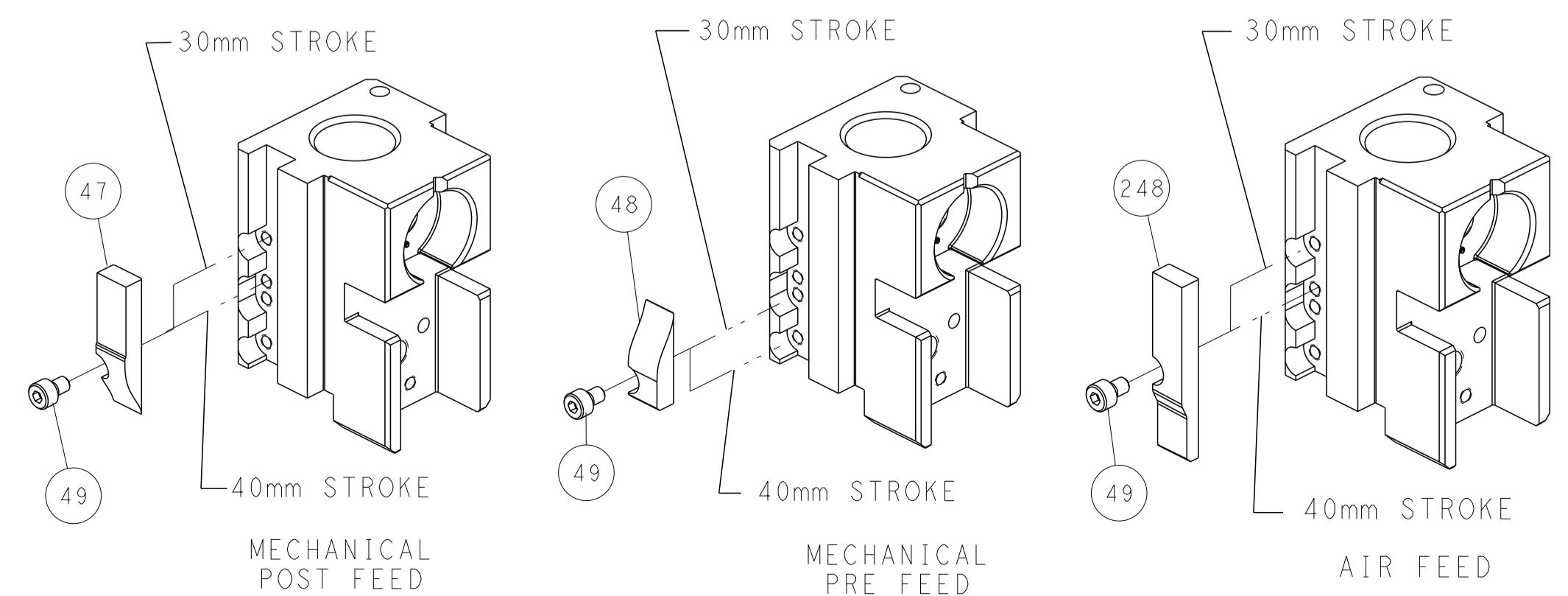

ATLANTIC VERSION
 Shown on sheets 1 of 4 & 2 of 4
 (Pacific version shown on sheets 3 of 4 & 4 of 4)

DIMENSIONS:		TOLERANCES UNLESS OTHERWISE SPECIFIED:		DWN: R. HUANG 04FEB2015		TE Connectivity	
mm	0 PLC ±	1 PLC ±	2 PLC ±	3 PLC ±	4 PLC ±	Harrisburg, PA 17105-3608	
MATERIAL:		FINISH:		CHK: M. RILEY 04FEB2015		NAME: Ocean Side Feed Applicator	
				APVD: J. ELBIN 04FEB2015		SIZE: A1	
				PRODUCT SPEC:		CAGE CODE: 00779	
				APPLICATION SPEC:		DRAWING NO: C=2266607	
				WEIGHT:		SCALE: 1:2	
				Customer Accessible Production Drawing		SHEET 2 OF 4	
						REV B	

PART NUMBER	REVISION	DESCRIPTION	FEED TYPE
2-2266607-1	B	FINE CRIMP HEIGHT ADJUST	MECHANICAL
2-2266607-2	B	FINE CRIMP HEIGHT ADJUST	PNEUMATIC
7-2266607-7	A	CRIMP TOOLING KIT	-

PACIFIC VERSION TERMINATOR
 INTERFACE ADAPTER



APPLICATOR DATA		
CRIMP	SIZE	TYPE
WIRE	1.85 mm [.073]	F
INSUL	2.54 mm [.100]	F

APPLICATOR INSTRUCTIONS
 408-35042

TERMINAL DATA: DELPHI TERMINAL DELPHI CRIMP SPECIFICATION	
TERMINAL NAME: CTS 2.8MM ASSEMBLY	
WIRE STRIP LENGTH 3.62-4.38 mm [1.43-.172 IN]	INSULATION DIAMETER RANGE Ø1.40-2.10 mm [.055-.083 IN]
TERMINAL APPLICATION SPECIFICATION 15457850 Rev 01	
TERMINALS APPLIED	
TE TERMINAL 2113630-1	DELPHI TERMINAL 15457848

WIRE SIZE	CRIMP HEIGHT mm [INCH]	CRIMP HEIGHT REFERENCE SETTING
1.00mm ²	1.40+/-0.05 [.055+/-0.002]	7.4
0.75mm ²	1.35+/-0.05 [.053+/-0.002]	7.9
0.50mm ²	1.25+/-0.05 [.049+/-0.002]	8.9



- RECOMMENDED SPARE PARTS
- REFER TO SUPPLIED INSTRUCTION SHEET FOR CLEANING, LUBRICATION AND STORAGE OF APPLICATOR.
- APPLY PART NUMBER 2-23419-6 LOCTITE TO THREADS OF ITEM 242.
- CRIMP HEIGHT REFERENCE SETTING WAS THE SETTING USED WHEN THE APPLICATOR WAS QUALIFIED AT THE FACTORY. ADJUSTMENT MAY BE NECESSARY WHEN RUNNING APPLICATOR IN THE FIELD.
- UNLESS SPECIFIED OTHERWISE TORQUE VALUES SHALL BE USED PER DOCUMENT, 101-35000

***WARNING**
 ON INSTALLATION, SET WIRE DISC TO CRIMP HEIGHT REFERENCE SETTING FOR LARGEST WIRE SIZE. CRIMP HEIGHT REFERENCE SETTINGS GREATER THAN THE VALUE SHOWN MAY CAUSE DAMAGE TO THE CRIMP TOOLING. REFER TO THE INSTRUCTION SHEET FOR PROPER SETUP AND ADJUSTMENTS.

LOC	DIST	REVISIONS					
A	66	P	LTN	DESCRIPTION	DATE	OWN	APVD
-	-	-	-	SEE SHEET 1	-	-	-

-	1	1	2119082-4	CAM, SNAIL, INSULATION ADJUSTMENT	244
-	1	1	2079764-1	WASHER, WAVE SPRING, CREST-TO-CREST	243
-	1	1	2119083-1	RETAINER, INSULATION DIAL	242
-	1	1	7-18023-7	SCR, SKT HD CAP M3 X 4.0	241
-	-	1	2119580-1	MECHANICAL FEED ASSEMBLY	239
-	1	-	2844940-1	AIR FEED MODULE	238
-	REF	REF	994970-2	COUNTER, MAGNETIC	164
-	1	-	2119641-2	FEED CAM, AIR FEED	151
-	1	1	2168083-8	SCR, SKT HD CAP, RoHS, M4 X 16	144
-	4	4	2168083-9	SCR, SKT HD CAP, RoHS, M4 X 20	143
-	-	1	2119653-2	FEED CAM, POST FEED	142
-	1	1	1-1803583-0	APPLICATOR BASIC ASSEMBLY, SF	141
-	1	1	1803516-1	RAM ASSEMBLY, SF PACIFIC	140
-	1	1	2844908-1	SCREW, LOCKING	99
-	1	1	2844907-1	POST, LOCKING	98
-	1	1	455888-7	SPACER, CRIMPER	82
-	1	1	1803607-3	DOCUMENTATION PACKAGE	71
-	1	1	2119740-1	TAG, IDENTIFICATION	67
-	2	2	2168078-1	SCREW, DRIVE, RH, RoHS, 2 x .188	66
-	1	1	5-18022-5	SCR, HEX HD CAP, M4 X 6.0	59
-	1	1	1338685-1	PAWL, FEED	56
-	2	2	1-2168083-0	SCR, SKT HD CAP, RoHS, M4 X 10	53
-	1	1	5018030-1	NUT, HEX, REG, RoHS, M3	52
-	1	1	811242-5	BUMPER, HOLD DOWN	51
-	1	1	690753-2	SPACER, TONKER	50
-	1	2	18023-9	SCR, SKT HD CAP M4 X 6.0	49
-	-	1	2119652-1	FEED CAM, PRE FEED	48
-	1	1	1803602-1	SCR, BHSC, RoHS (M8 X 25)	41
-	1	1	1-1752356-7	SUPPORT, TERMINAL	34
-	2	2	2079383-5	SCR, BHSC, RoHS (M4 X 20)	33
-	2	2	2-2844962-6	SPACER, CYLINDRICAL, STRIP GUIDE	30
-	1	1	2844992-1	ASSEMBLY, STRIP GUIDE	29
-	1	1	455888-3	SPACER, CRIMPER	28
-	1	1	1320928-2	STRIP GUIDE	24
-	1	1	2168083-2	SCR, SKT HD CAP, RoHS, M4 X 8.0	21
-	2	2	1-18028-2	WASHER, FLAT, REG M4	20
-	1	1	2119533-1	STRIPPER, SIDE FEED	19
-	1	1	2119806-1	INSERT, SHEAR	13
-	1	1	3-22280-3	SPRING, COMPRESSION	12
-	1	1	1-356885-4	STOP, SHEAR	11
-	1	1	2119805-1	SHEAR HOLDER, FRONT	10
-	1	1	1803095-6	FLOATING SHEAR, FRONT	9
-	1	1	1-1803054-4	ANVIL, COMBINATION	8
-	-	-	-	-	7
-	-	-	-	-	6
-	1	1	2119757-8	DEPRESSOR, SHEAR	5
-	1	1	238011-4	BLOCK, CRIMPER SPACER	4
-	1	1	7-1633962-9	CRIMPER, INSULATION F PREMIUM	3
-	1	1	455888-3	SPACER, CRIMPER	2
-	1	1	4-1633860-4	CRIMPER, WIRE	1

PACIFIC VERSION
 Shown on sheets 3 of 4 & 4 of 4
 (Atlantic version shown on sheets 1 of 4 & 2 of 4)

DIMENSIONS: mm		TOLERANCES UNLESS OTHERWISE SPECIFIED:		DRAWING NO		RESTRICTED TO	
0 PLC	±	0.15	±	04FEB2015	-		
1 PLC	±	0.25	±	04FEB2015	-		
2 PLC	±	0.38	±	04FEB2015	-		
3 PLC	±	0.51	±	04FEB2015	-		
4 PLC	±	0.64	±	04FEB2015	-		
ANGLES	±	0.15	±	04FEB2015	-		
FINISH	±	0.15	±	04FEB2015	-		

OWN	H. HUANG	04FEB2015	TE Connectivity	
CHK	M. RILEY	04FEB2015	Harrisburg, PA 17105-3608	
APVD	T. ELBIN	04FEB2015	NAME	
PRODUCT SPEC	Ocean Side Feed Applicator			
APPLICATION SPEC	-			
SIZE	CAGE CODE	DRAWING NO	RESTRICTED TO	
A1	00779	2266607	-	
Customer Accessible Production Drawing			SCALE	1:2
			SHEET	3 OF 4
			REV	B

LOC		DIST		REVISIONS			
A	66	P	LTM	DESCRIPTION	DATE	OWN	APVD
		-		SEE SHEET 1			

FEED TYPE MECHANICAL

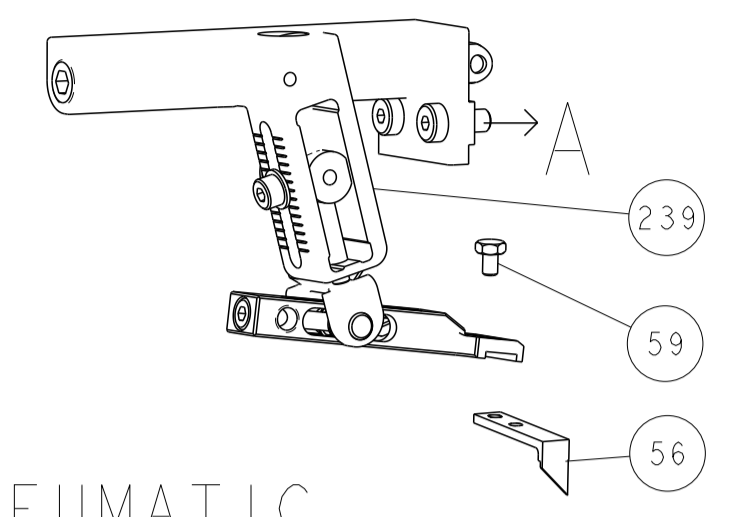

PNEUMATIC

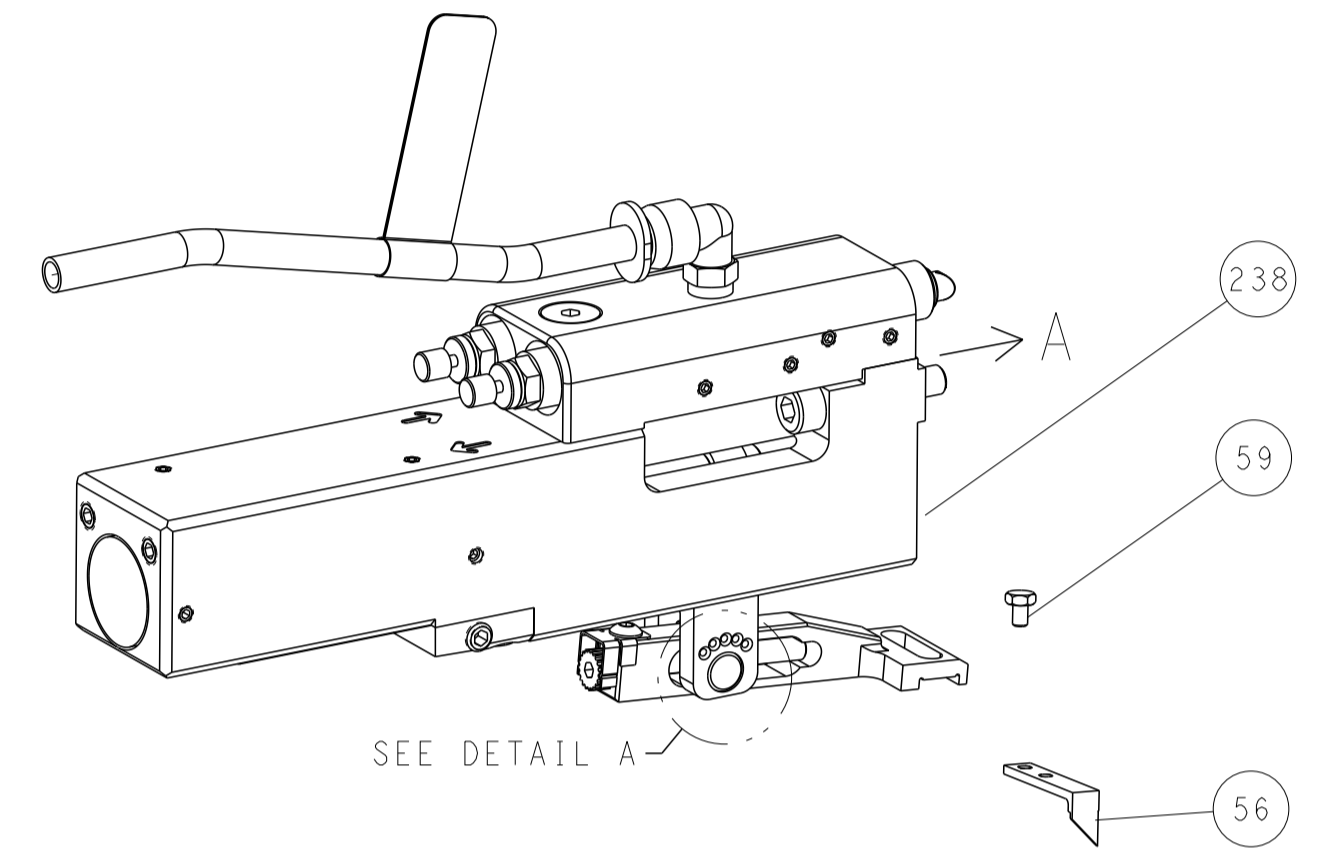

FEED SPRING SETTING POSITION (SHOWN FROM REAR SIDE)

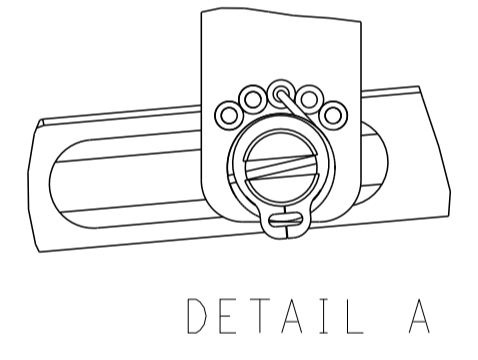

DETAIL A

CAM POSITIONS

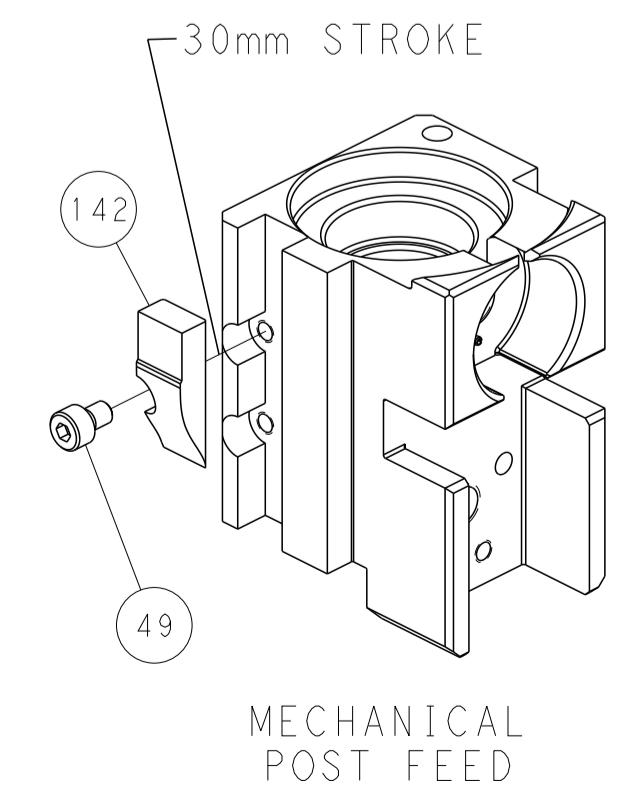

MECHANICAL
POST FEED

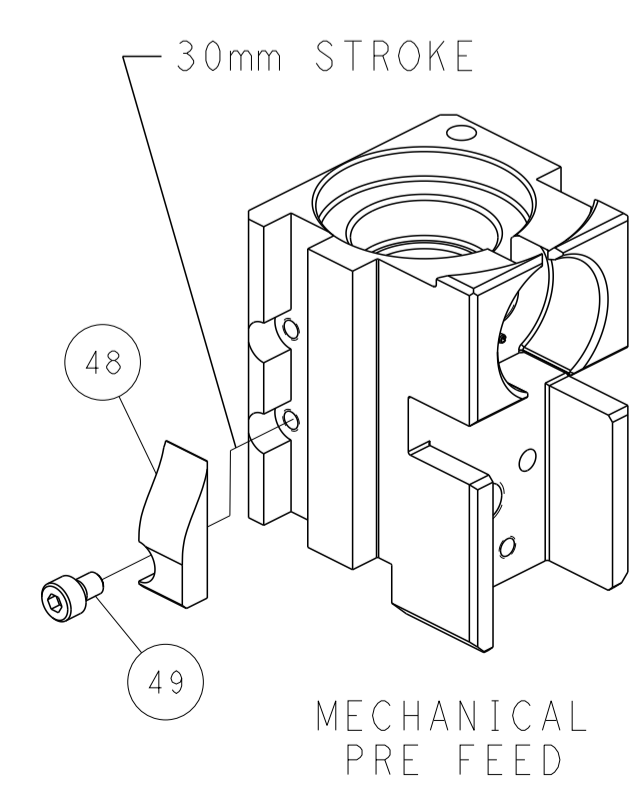

MECHANICAL
PRE FEED

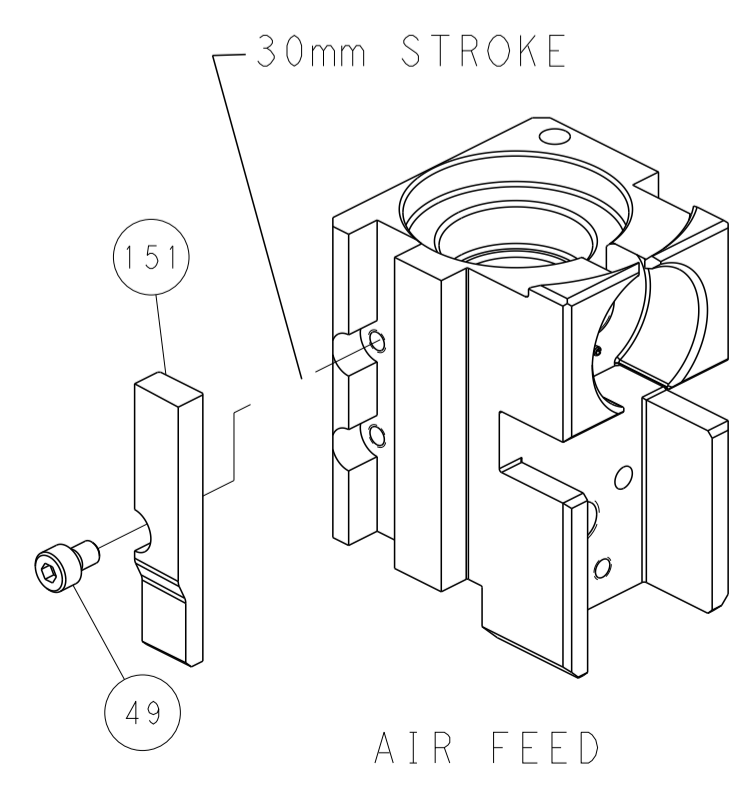

AIR FEED

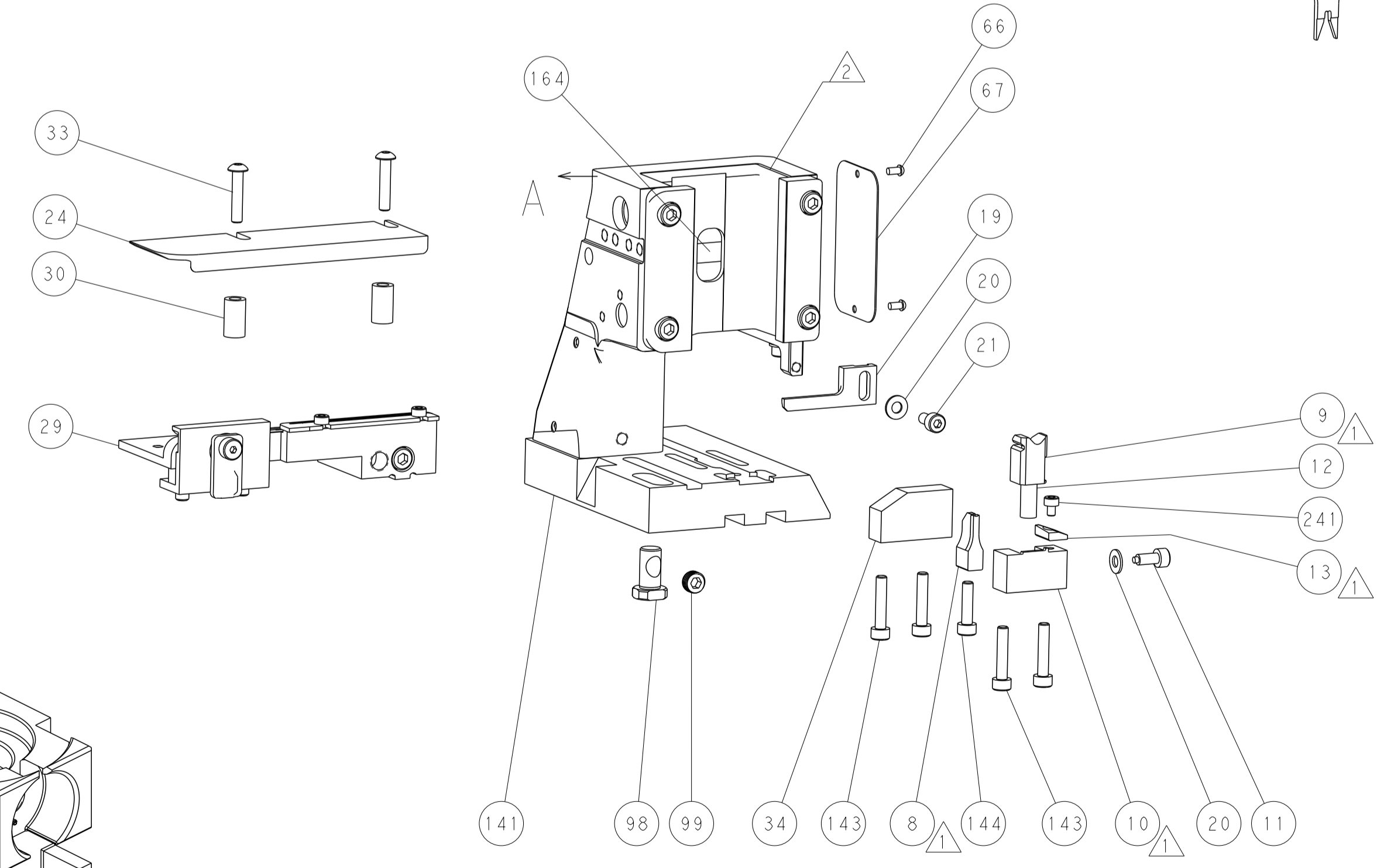

PACIFIC VERSION
 Shown on sheets 3 of 4 & 4 of 4
 (Atlantic version shown on sheets 1 of 4 & 2 of 4)

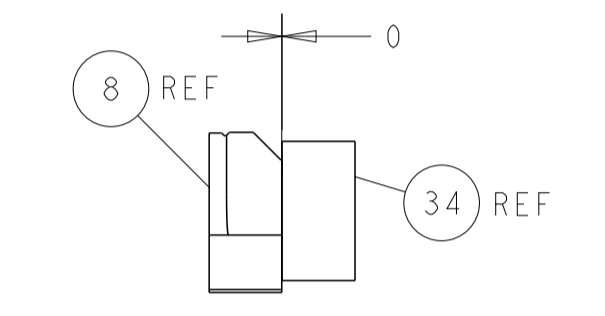

TERMINAL SUPPORT LOCATION

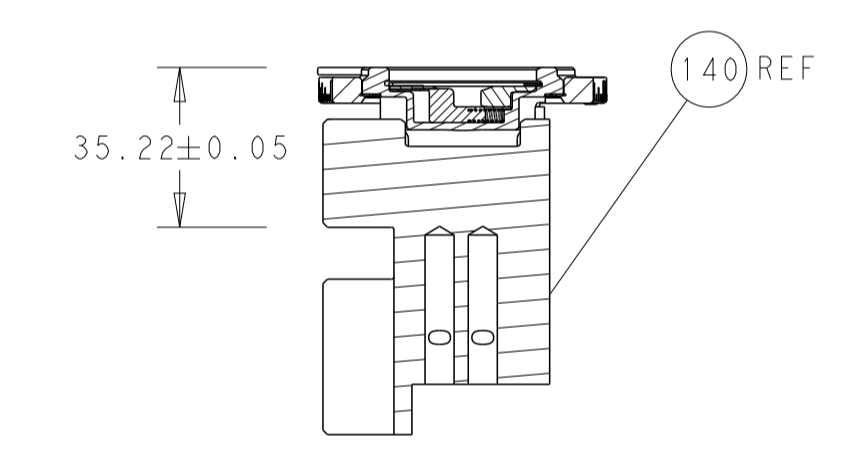

RAM SET-UP

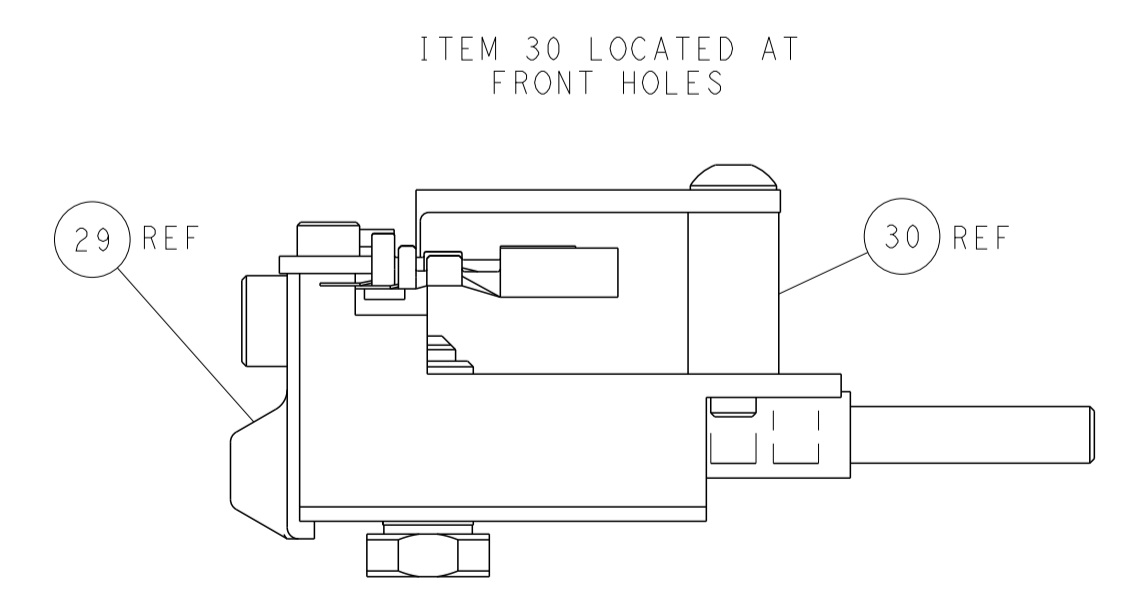

FEED TRACK POSITION
GUIDE BY INSULATION BARREL

<small>THIS DRAWING IS UNPUBLISHED. RELEASED FOR PUBLICATION. ALL RIGHTS RESERVED. THIS DRAWING IS CONTROLLED DOCUMENT. FOR THE ELECTRONICS CORPORATION. IT IS THE PROPERTY OF COMPANY AND IS NOT TO BE REPRODUCED OR TRANSMITTED IN ANY FORM OR BY ANY MEANS, ELECTRONIC OR MECHANICAL, INCLUDING PHOTOCOPYING, RECORDING, OR BY ANY INFORMATION STORAGE AND RETRIEVAL SYSTEM, WITHOUT THE WRITTEN PERMISSION OF THE COMPANY.</small>		DWN R. HUANG 04FEB2015 CHK M. RILEY 04FEB2015 APVD T. ELBIN 04FEB2015	NAME Ocean Side Feed Applicator
DIMENSIONS: mm 	TOLERANCES UNLESS OTHERWISE SPECIFIED: 0 PLC ± 1 PLC ± 2 PLC ± 3 PLC ± 4 PLC ± ANGLES ± FINISH	PRODUCT SPEC APPLICATION SPEC WEIGHT SCALE 1:2	SIZE CAGE CODE DRAWING NO A1 00779 C=2266607 RESTRICTED TO SHEET 4 OF 4 REV B

Mouser Electronics

Authorized Distributor

Click to View Pricing, Inventory, Delivery & Lifecycle Information:

[TE Connectivity:](#)

[2266607-1](#)