

PART NUMBER	REVISION	DESCRIPTION	FEED TYPE
2151915-1	B	FINE CRIMP HEIGHT ADJUST	MECHANICAL
2151915-2	C	FINE CRIMP HEIGHT ADJUST	PNEUMATIC
7-2151915-1	B	MECHANICAL AND CRIMP TOOLING KIT	MECHANICAL
7-2151915-2	C	PNEUMATIC AND CRIMP TOOLING KIT	PNEUMATIC
7-2151915-7	A	CRIMP TOOLING KIT	-

ATLANTIC VERSION TERMINATOR INTERFACE ADAPTER

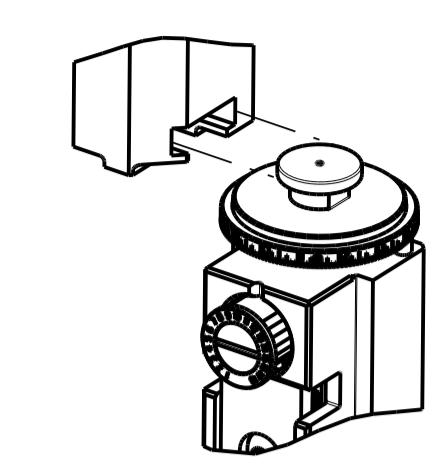

APPLICATOR DATA		
CRIMP	SIZE	TYPE
WIRE	2.54 mm [.100]	F
INSUL	5.08 mm [.200]	F

APPLICATOR INSTRUCTIONS 408-35042

TERMINAL DATA: TE TERMINAL		TE CRIMP SPECIFICATION	
TERMINAL NAME: UNIVERSAL MATE-N-LOCK PIN AND SOCKET			
WIRE STRIP LENGTH		INSULATION DIAMETER RANGE	
3.40-4.20 mm [.134-.165 IN]		Ø3.30-5.11 mm [.130-.201 IN]	
TERMINAL APPLICATION SPECIFICATION	114-18011	-	-
TERMINALS APPLIED			
TE TERMINAL	TE TERMINAL	TE TERMINAL	TE TERMINAL
926868-1	926868-7	926899-4	926869-1
926868-3	926899-1	926899-5	926869-3
926868-4	926899-1	926899-6	926869-4
926868-6	926899-3	926899-7	926869-6

TERMINAL DATA: TE TERMINAL		TE CRIMP SPECIFICATION	
TERMINAL NAME: UNIVERSAL MATE-N-LOCK PIN AND SOCKET			
WIRE STRIP LENGTH		INSULATION DIAMETER RANGE	
3.40-4.20 mm [.134-.165 IN]		Ø3.30-5.11 mm [.130-.201 IN]	
TERMINAL APPLICATION SPECIFICATION		-	-
TERMINALS APPLIED			
TE TERMINAL	TE TERMINAL	TE TERMINAL	TE TERMINAL
926868-1	926868-3		

WIRE SIZE	CRIMP HEIGHT mm [INCH]	CRIMP HEIGHT REFERENCE SETTING
14 AWG	1.72+/-0.05 [.068+/- .002]	7.4
16 AWG	1.49+/-0.05 [.059+/- .002]	9.9

WIRE SIZE	CRIMP HEIGHT mm [INCH]	CRIMP HEIGHT REFERENCE SETTING
2.50mm2	1.78+/-0.05 [.070+/- .002]	6.9
1.50mm2	1.50+/-0.05 [.059+/- .002]	9.8

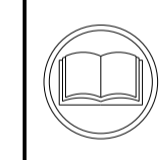

- 1 RECOMMENDED SPARE PARTS
- 2 REFER TO SUPPLIED INSTRUCTION SHEET FOR CLEANING, LUBRICATION AND STORAGE OF APPLICATOR.
- 3 APPLY PART NUMBER 2-23419-6 LOCTITE TO THREADS OF ITEM 242.
- 4 CRIMP HEIGHT REFERENCE SETTING WAS THE SETTING USED WHEN THE APPLICATOR WAS QUALIFIED AT THE FACTORY. ADJUSTMENT MAY BE NECESSARY WHEN RUNNING APPLICATOR IN THE FIELD.
- 5 CUT TO LENGTH AT ASSEMBLY.
- 6 THIS CRIMP PARAMETER IS PROVIDED TO MEET A CUSTOM AND UNIQUE CUSTOMER REQUIREMENT. IT HAS BEEN EVALUATED AND IS CONDITIONALLY SPECIFIED BY TE CONNECTIVITY. THIS CUSTOMIZED CRIMP PARAMETER IS NOT LISTED AS AN APPROVED APPLICATION WITHIN A TE CONNECTIVITY APPLICATION SPECIFICATION; HOWEVER, IT HAS BEEN VALIDATED ACCORDING TO TE CONNECTIVITY SPECIFICATIONS 109-18079 (TEST GROUP 1) AND 114-18022. **TE CONNECTIVITY EXPRESSLY DISCLAIMS ANY AND ALL WARRANTIES THAT THE PRODUCT WILL PERFORM SIMILARLY TO VALIDATED AND APPROVED APPLICATIONS, AS STATED WITHIN TE CONNECTIVITY APPLICATION SPECIFICATIONS, INCLUDING BUT NOT LIMITED TO IMPLIED WARRANTIES OF MERCHANTABILITY OR FITNESS FOR PARTICULAR PURPOSE.** AS SUCH, IT IS HIGHLY RECOMMENDED THAT THE CUSTOMER PERFORM FURTHER DETAILED EVALUATION TO ASSESS PRODUCT PERFORMANCE IN THE SPECIFIC APPLICATION.

***WARNING**
ON INSTALLATION, SET WIRE DISC TO CRIMP HEIGHT REFERENCE SETTING FOR LARGEST WIRE SIZE. CRIMP HEIGHT REFERENCE SETTINGS GREATER THAN THE VALUES SHOWN MAY CAUSE DAMAGE TO THE CRIMP TOOLING, REFER TO THE INSTRUCTION SHEET FOR PROPER SETUP AND ADJUSTMENTS.

7. UNLESS SPECIFIED OTHERWISE TORQUE VALUES SHALL BE USED PER DOCUMENT, 101-35000.

LOC	DIST	REV	LTN	DESCRIPTION	DATE	OWN	APVD
A	66						
		A1		ECR-16-005304	12APR2016	JH	JDG
		A2		ECR-16-007061	16MAY2016	KH	JDG
		B		ECR-18-007144	11MAY2018	VLA	JDG
		C		ECR-21-002833	05MAR2021	FJ	TE

-	1	-	1	-	2119641-1	FEED CAM, AIR FEED	248	
-	1	1	1	1	2119082-9	CAM, SNAIL, INSULATION ADJUSTMENT	244	
-	1	1	1	1	2079764-1	WASHER, WAVE SPRING, CREST-TO-CREST	243	
-	1	1	1	1	2119083-1	RETAINER, INSULATION DIAL	242	
-	1	1	1	1	7-18023-7	SCR, SKT HD CAP M3 X 4.0	241	
-	-	1	-	1	2119580-1	MECHANICAL FEED ASSEMBLY	239	
-	1	-	1	-	2844940-1	AIR FEED MODULE	238	
-	REF	REF	REF	REF	994970-2	COUNTER, MAGNETIC	164	
-	1	1	1	1	1-18028-2	WASHER, FLAT, REG M4	119	
-	1	1	1	1	2844908-1	SCREW, LOCKING	99	
-	1	1	1	1	2844907-1	POST, LOCKING	98	
-	1	1	1	1	455888-5	SPACER, CRIMPER	82	
-	1	1	1	1	1803607-3	DOCUMENTATION PACKAGE	71	
-	1	1	1	1	2119740-1	TAG, IDENTIFICATION	67	
-	2	2	2	2	2168078-1	SCREW, DRIVE, RH, RoHS, 2 x .188	66	
-	1	1	1	1	2168083-2	SCR, SKT HD CAP, RoHS, M4 X 8.0	60	
-	1	1	1	1	5-18022-5	SCR, HEX HD CAP, M4 X 6.0	59	
-	1	1	1	1	1338685-1	PAWL, FEED	56	
-	4	4	4	4	2168083-3	SCR, SKT HD CAP, RoHS, M4 X 12.0	54	
-	2	2	2	2	2168083-8	SCR, SKT HD CAP, RoHS, M4 X 16	53	
-	1	1	1	1	5018030-1	NUT, HEX, REG, RoHS, M3	52	
-	1	1	1	1	811242-5	BUMPER, HOLD DOWN	51	
-	1	1	1	1	690753-2	SPACER, TONKER	50	
-	1	2	1	2	18023-9	SCR, SKT HD CAP M4 X 6.0	49	
-	-	1	-	1	2119652-1	FEED CAM, PRE FEED	48	
-	-	1	-	1	2119653-1	FEED CAM, POST FEED	47	
-	1	1	1	1	1803583-9	APPLICATOR BASIC ASSEMBLY, SF	46	
-	1	1	1	1	1803515-1	RAM ASSEMBLY, SF ATLANTIC	44	
-	1	1	1	1	1803602-1	SCR, BHSC, RoHS (M8 X 25)	41	
-	1	1	1	1	1752356-1	SUPPORT, TERMINAL	34	
-	2	2	2	2	2079383-5	SCR, BHSC, RoHS (M4 X 20)	33	
-	2	2	2	2	3-2844962-0	SPACER, CYLINDRICAL, STRIP GUIDE	30	
-	1	1	1	1	2844992-1	ASSEMBLY, STRIP GUIDE	29	
-	1	1	1	1	1-455888-0	SPACER, CRIMPER	28	
-	1	1	1	1	1320928-2	STRIP GUIDE	24	
-	1	1	1	1	2168083-2	SCR, SKT HD CAP, RoHS, M4 X 8.0	21	
-	1	1	1	1	1-18028-2	WASHER, FLAT, REG M4	20	
-	1	1	1	1	2119533-1	STRIPPER, SIDE FEED	19	
-	1	1	1	1	2119806-1	INSERT, SHEAR	13	
-	1	1	1	1	3-22280-3	SPRING, COMPRESSION	12	
-	1	1	1	1	1-356885-4	STOP, SHEAR	11	
-	1	1	1	1	2119805-1	SHEAR HOLDER, FRONT	10	
-	1	1	1	1	462006-6	FLOATING SHEAR, FRONT	9	
-	1	2	2	1	1333206-4	ANVIL, COMBINATION .100	8	
-	1	1	1	1	240641-5	SPACER	7	
-	-	-	-	-	-	-	6	
-	1	1	1	1	1-2119757-1	DEPRESSOR, SHEAR	5	
-	1	1	1	1	238011-4	BLOCK, CRIMPER SPACER	4	
-	1	2	2	1	3-1633961-4	CRIMPER, INSULATION F PREMIUM	3	
-	1	1	1	1	455888-1	SPACER, CRIMPER	2	
-	1	2	2	1	1-456407-3	CRIMPER, WIRE PREMIUM	1	
-	77	-72	-71	-2	-1	PART NO	ITEM NO	
							DESCRIPTION	

ATLANTIC VERSION
Shown on sheets 1 of 4 & 2 of 4
(Pacific version shown on sheets 3 of 4 & 4 of 4)

DIMENSIONS:		TOLERANCES UNLESS OTHERWISE SPECIFIED:		MATERIAL:		FINISH:		WEIGHT:		SCALE:		SHEET:		REV:	
mm	0 PLC	±													
	1 PLC	±													
	2 PLC	±													
	3 PLC	±													
	4 PLC	±													
	ANGLES	±													

LOC		DIST		REVISIONS			
A	66	P	LTN	DESCRIPTION	DATE	DWN	APVD
		-		SEE SHEET 1	-	-	-

FEED TYPE MECHANICAL

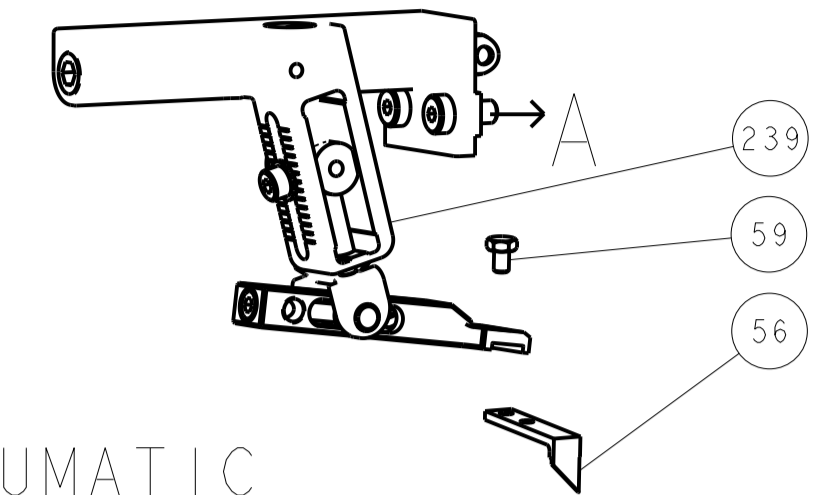

PNEUMATIC

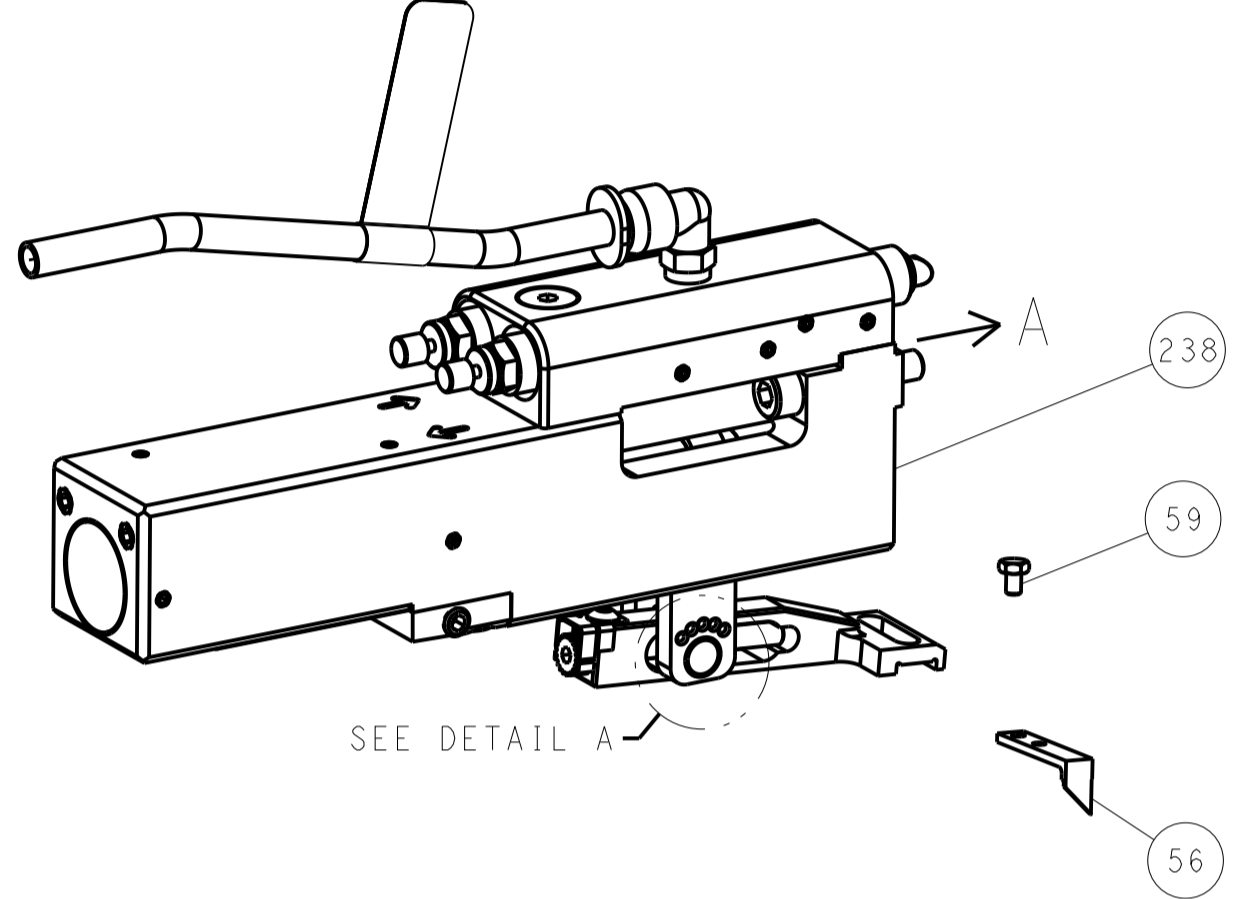

FEED SPRING SETTING POSITION (SHOWN FROM REAR SIDE)

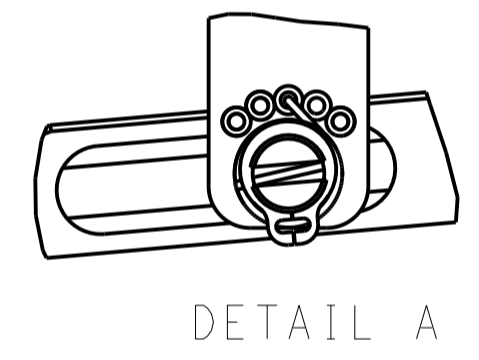

DETAIL A

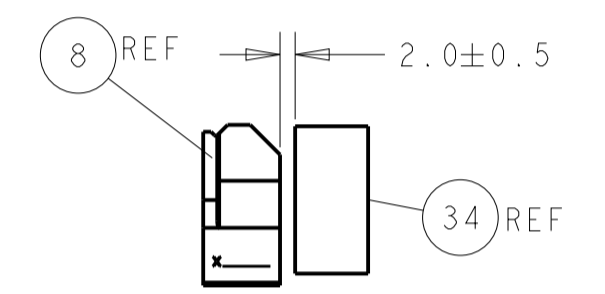
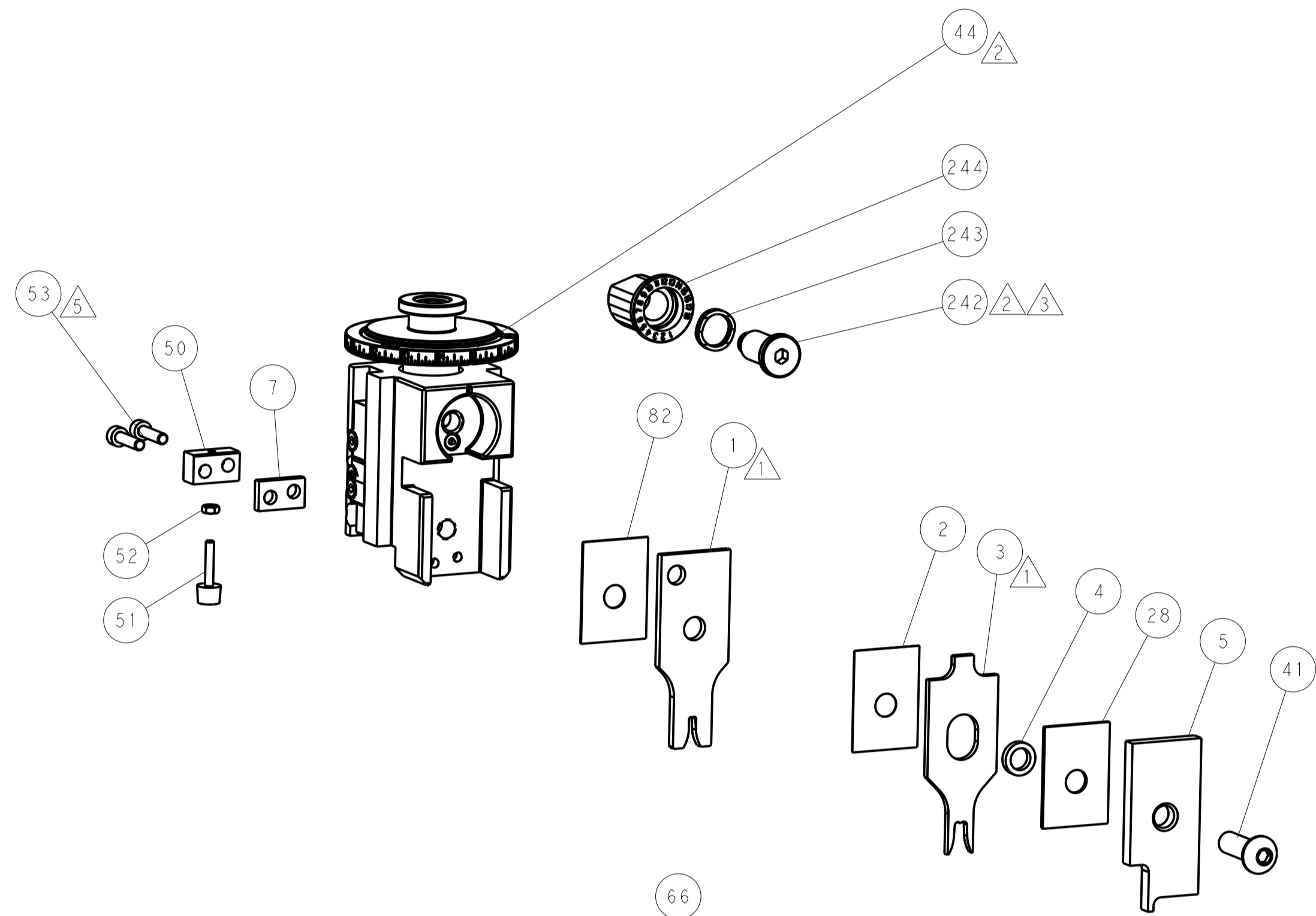

TERMINAL SUPPORT LOCATION

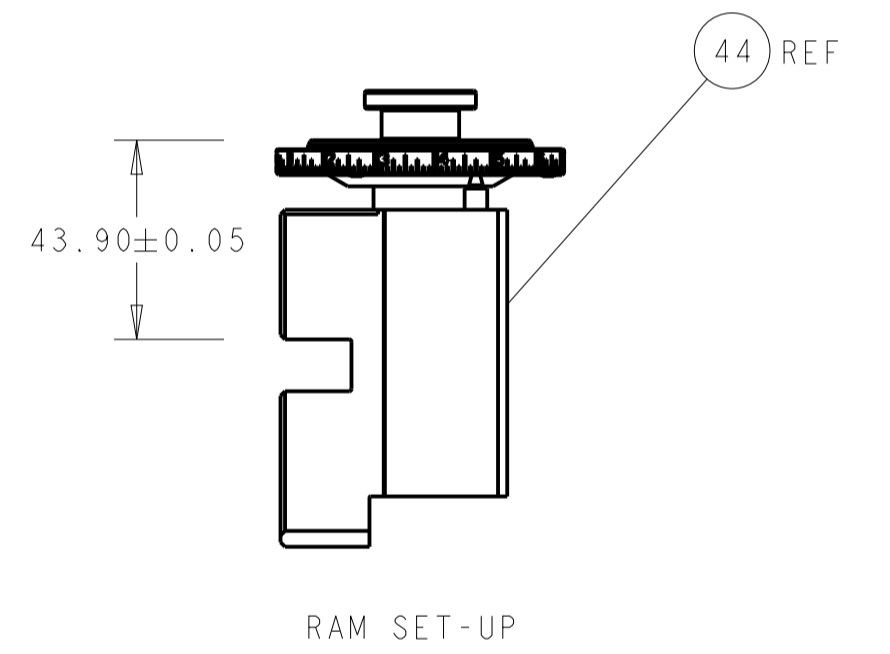

RAM SET-UP

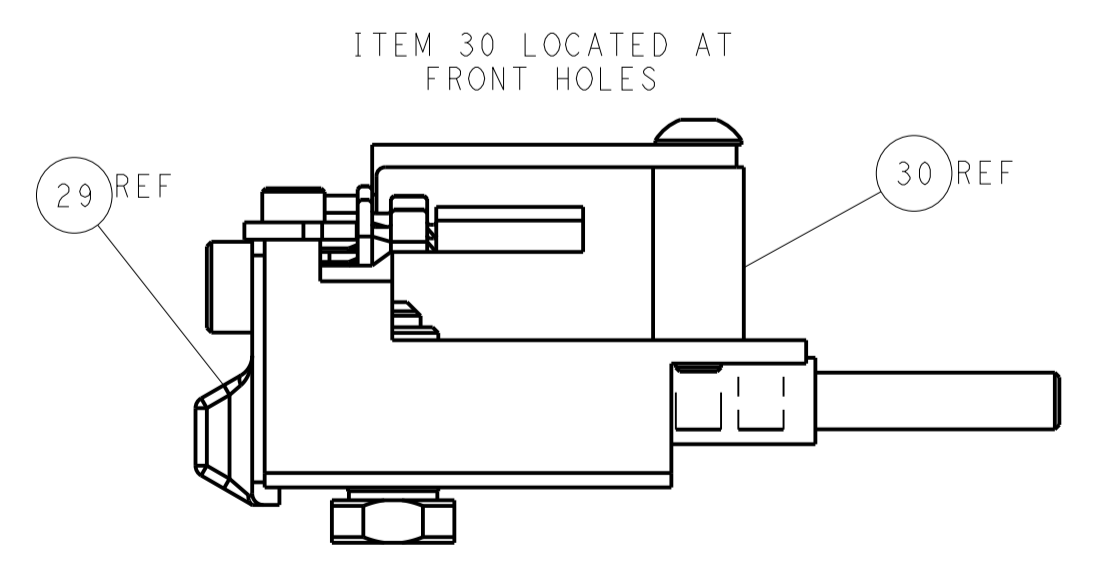
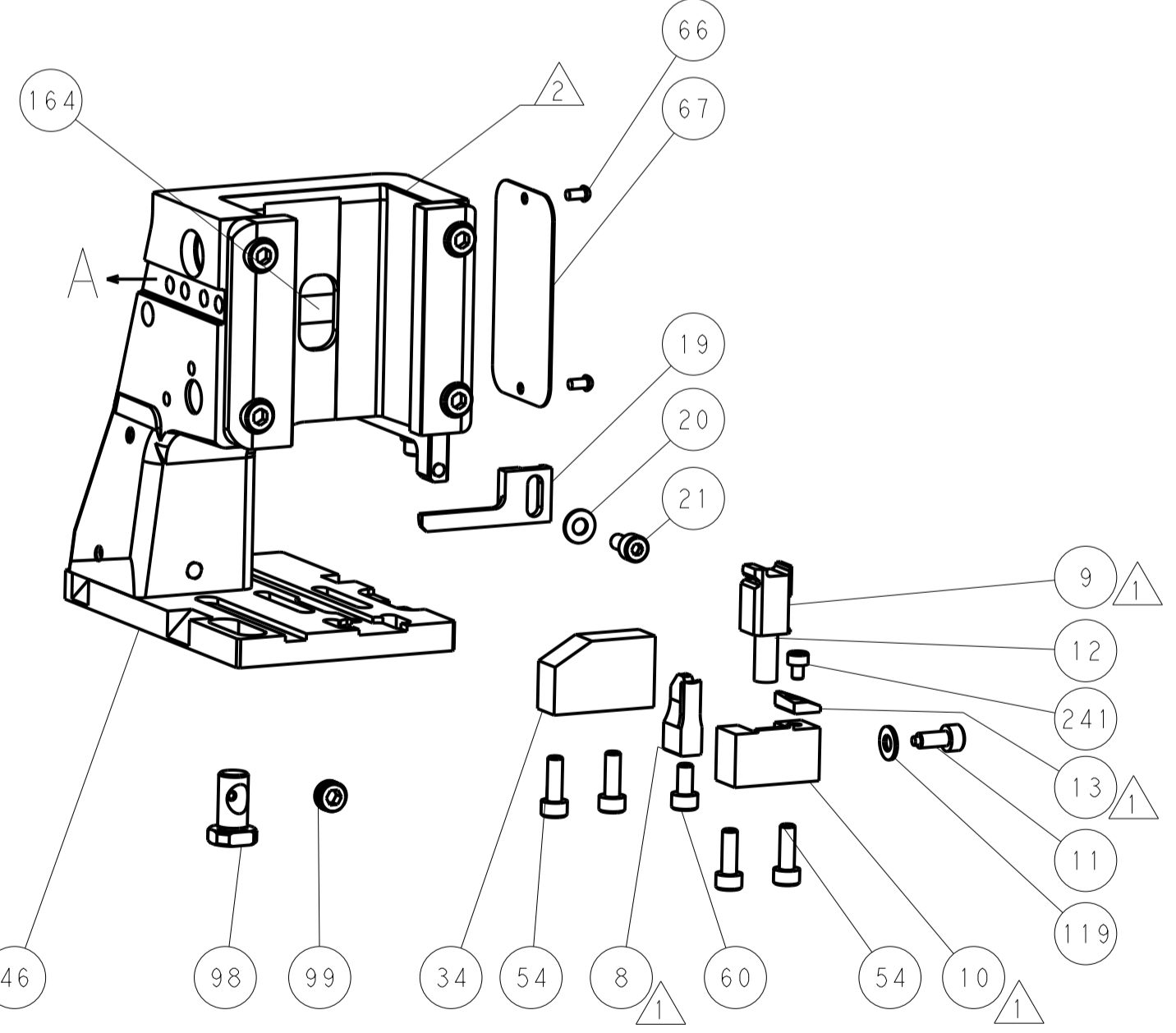
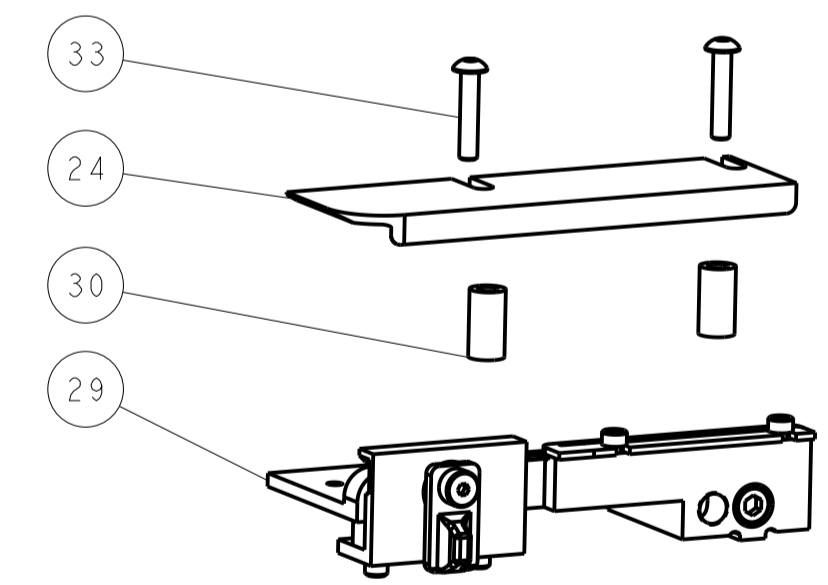

FEED TRACK POSITION GUIDE BY INSULATION BARREL

CAM POSITIONS

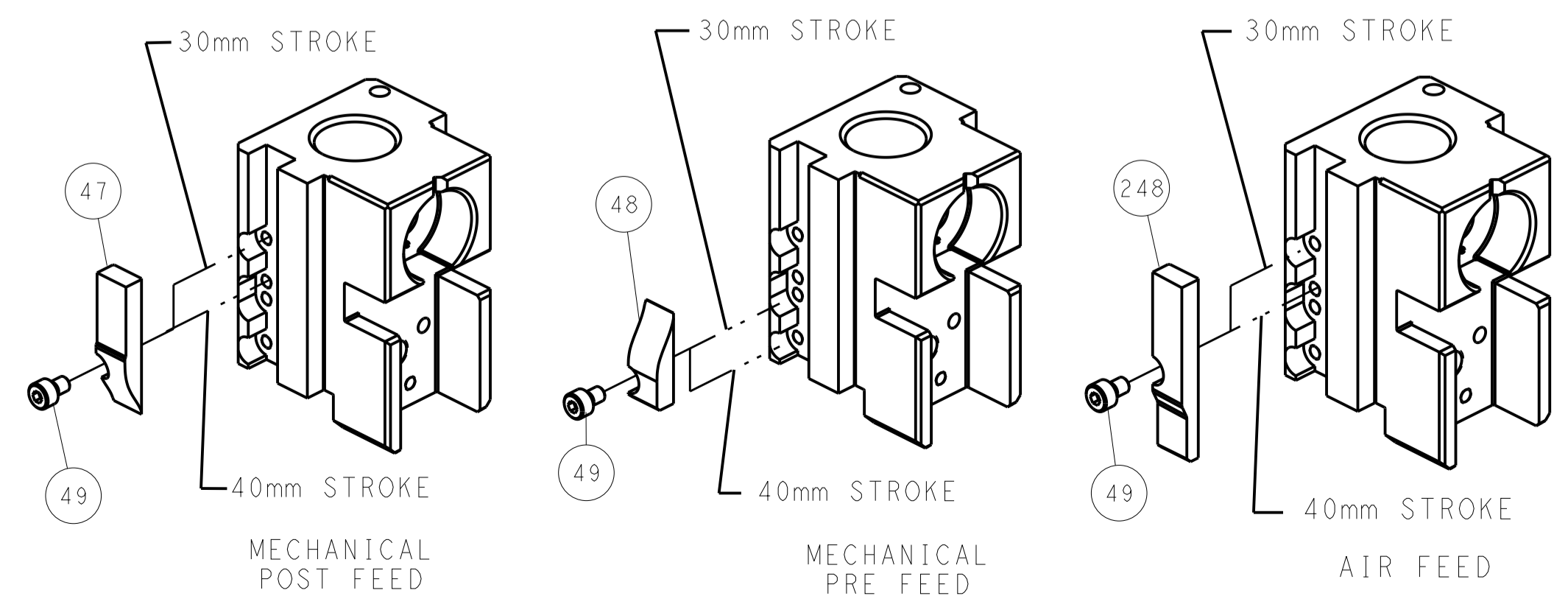

ATLANTIC VERSION
 Shown on sheets 1 of 4 & 2 of 4
 (Pacific version shown on sheets 3 of 4 & 4 of 4)

DIMENSIONS:		TOLERANCES UNLESS OTHERWISE SPECIFIED:		OWN: BOB HIGMAN 22MAR2013		TE Connectivity	
mm	0 PLC	±		CHK: G. BAILEY 22MAR2013	NAME: Ocean Side Feed Applicator		Harrisburg, PA 17105-3608
	1 PLC	±		APVD: M. CLIFFORD 22MAR2013	SIZE: CAGE CODE: DRAWING NO: A1100779		RESTRICTED TO
	2 PLC	±		PRODUCT SPEC:		©=2151915	
	3 PLC	±		APPLICATION SPEC:		SCALE: 1:2 SHEET 2 OF 4 REV C	
	4 PLC	±		WEIGHT:		Customer Accessible Production Drawing	
	ANGLES	±		MATERIAL:		Customer Accessible Production Drawing	

PART NUMBER	REVISION	DESCRIPTION	FEED TYPE
2-2151915-1	B	FINE CRIMP HEIGHT ADJUST	MECHANICAL
2-2151915-2	C	FINE CRIMP HEIGHT ADJUST	PNEUMATIC
7-2151915-7	A	CRIMP TOOLING KIT	-

PACIFIC VERSION TERMINATOR
INTERFACE ADAPTER



APPLICATOR DATA		
CRIMP	SIZE	TYPE
WIRE	2.54 mm [.100]	F
INSUL	5.08 mm [.200]	F
APPLICATOR INSTRUCTIONS 408-35042		

TERMINAL DATA: TE TERMINAL		TE CRIMP SPECIFICATION	
TERMINAL NAME: UNIVERSAL MATE-N-LOCK PIN AND SOCKET			
WIRE STRIP LENGTH		INSULATION DIAMETER RANGE	
3.40-4.20 mm [1.34-.165 IN]		Ø3.30-5.11 mm [1.30-.201 IN]	
TERMINAL APPLICATION SPECIFICATION	114-18011	-	-
TERMINALS APPLIED			
TE TERMINAL	TE TERMINAL	TE TERMINAL	TE TERMINAL
926868-1	926868-7	926899-4	926869-1
926868-3	926899-1	926899-5	926869-3
926868-4	926899-1	926899-6	926869-4
926868-6	926899-3	926899-7	926869-6

TERMINAL DATA: TE TERMINAL		TE CRIMP SPECIFICATION	
TERMINAL NAME: UNIVERSAL MATE-N-LOCK PIN AND SOCKET			
WIRE STRIP LENGTH		INSULATION DIAMETER RANGE	
3.40-4.20 mm [1.34-.165 IN]		Ø3.30-5.11 mm [1.30-.201 IN]	
TERMINAL APPLICATION SPECIFICATION	6	-	-
TERMINALS APPLIED			
TE TERMINAL	TE TERMINAL	TE TERMINAL	TE TERMINAL
926868-1	926868-3		

WIRE SIZE	CRIMP HEIGHT mm [INCH]	CRIMP HEIGHT REFERENCE SETTING
14 AWG	1.72 +/- 0.05 [1.068 +/- .002]	7.4
16 AWG	1.49 +/- 0.05 [1.059 +/- .002]	9.9

WIRE SIZE	CRIMP HEIGHT mm [INCH]	CRIMP HEIGHT REFERENCE SETTING
2.50mm2	1.78 +/- 0.05 [1.070 +/- .002]	6.9
1.50mm2	1.50 +/- 0.05 [1.059 +/- .002]	9.8

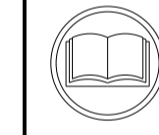

- RECOMMENDED SPARE PARTS
- REFER TO SUPPLIED INSTRUCTION SHEET FOR CLEANING, LUBRICATION AND STORAGE OF APPLICATOR.
- APPLY PART NUMBER 2-23419-6 LOCTITE TO THREADS OF ITEM 242.
- CRIMP HEIGHT REFERENCE SETTING WAS THE SETTING USED WHEN THE APPLICATOR WAS QUALIFIED AT THE FACTORY. ADJUSTMENT MAY BE NECESSARY WHEN RUNNING APPLICATOR IN THE FIELD.
- CUT TO LENGTH AT ASSEMBLY.
- THIS CRIMP PARAMETER IS PROVIDED TO MEET A CUSTOM AND UNIQUE CUSTOMER REQUIREMENT. IT HAS BEEN EVALUATED AND IS CONDITIONALLY SPECIFIED BY TE CONNECTIVITY. THIS CUSTOMIZED CRIMP PARAMETER IS NOT LISTED AS AN APPROVED APPLICATION WITHIN A TE CONNECTIVITY APPLICATION SPECIFICATION; HOWEVER, IT HAS BEEN VALIDATED ACCORDING TO TE CONNECTIVITY SPECIFICATIONS 109-18079 (TEST GROUP 1) AND 114-18022. **TE CONNECTIVITY EXPRESSLY DISCLAIMS ANY AND ALL WARRANTIES THAT THE PRODUCT WILL PERFORM SIMILARLY TO VALIDATED AND APPROVED APPLICATIONS, AS STATED WITHIN TE CONNECTIVITY APPLICATION SPECIFICATIONS, INCLUDING BUT NOT LIMITED TO IMPLIED WARRANTIES OF MERCHANTABILITY OR FITNESS FOR PARTICULAR PURPOSE.** AS SUCH, IT IS HIGHLY RECOMMENDED THAT THE CUSTOMER PERFORM FURTHER DETAILED EVALUATION TO ASSESS PRODUCT PERFORMANCE IN THE SPECIFIC APPLICATION.

***WARNING**
ON INSTALLATION, SET WIRE DISC TO CRIMP HEIGHT REFERENCE SETTING FOR LARGEST WIRE SIZE. CRIMP HEIGHT REFERENCE SETTINGS GREATER THAN THE VALUE SHOWN MAY CAUSE DAMAGE TO THE CRIMP TOOLING, REFER TO THE INSTRUCTION SHEET FOR PROPER SETUP AND ADJUSTMENTS.

7. UNLESS SPECIFIED OTHERWISE TORQUE VALUES SHALL BE USED PER DOCUMENT, 101-35000.

LOC	DIST	REV	DATE	BY	APPV
A	66	-	-	-	-

REV	DATE	DESCRIPTION	DATE	BY	APPV
-	1 1	2119082-9			244
-	1 1	2079764-1			243
-	1 1	2119083-1			242
-	1 1	7-18023-7			241
-	- 1	2119580-1			239
-	1 -	2844940-1			238
-	REF REF	994970-2			164
-	1 -	2119641-2			151
-	1 1	2168083-8			144
-	4 4	2168083-9			143
-	- 1	2119653-2			142
-	1 1	1-1803583-0			141
-	1 1	1803516-1			140
-	1 1	1-18028-2			119
-	1 1	2844908-1			99
-	1 1	2844907-1			98
-	1 1	455888-5			82
-	1 1	1803607-3			71
-	1 1	2119740-1			67
-	2 2	2168078-1			66
-	1 1	5-18022-5			59
-	1 1	1338685-1			56
-	2 2	2168083-8			53
-	1 1	5018030-1			52
-	1 1	811242-5			51
-	1 1	690753-2			50
-	1 2	18023-9			49
-	- 1	2119652-1			48
-	1 1	1803602-1			41
-	1 1	1752356-1			34
-	2 2	2079383-5			33
-	2 2	3-2844962-0			30
-	1 1	2844992-1			29
-	1 1	1-455888-0			28
-	1 1	1320928-2			24
-	1 1	2168083-2			21
-	1 1	1-18028-2			20
-	1 1	2119533-1			19
-	1 1	2119806-1			13
-	1 1	3-22280-3			12
-	1 1	1-356885-4			11
-	1 1	2119805-1			10
-	1 1	462006-6			9
-	1 1	1333206-4			8
-	1 1	240641-5			7
-	- -	-			6
-	1 1	1-2119757-1			5
-	1 1	238011-4			4
-	1 1	3-1633961-4			3
-	1 1	455888-1			2
-	1 1	1-456407-3			1

DIMENSIONS:		TOLERANCES UNLESS OTHERWISE SPECIFIED:		DWG: BOB HIGMAN 22MAR2013	
mm	0 PLC ±	1 PLC ±	2 PLC ±	3 PLC ±	4 PLC ±
ANGLES	±	±	±	±	±
MATERIAL:	FINISH:	WEIGHT:	SCALE:	CAGE CODE:	DRAWING NO:
-	-	-	1:2	00779	2151915
Customer Accessible Production Drawing			RESTRICTED TO		

PACIFIC VERSION
Shown on sheets 3 of 4 & 4 of 4
(Atlantic version shown on sheets 1 of 4 & 2 of 4)

LOC		DIST		REVISIONS			
A	66	P	LTM	DESCRIPTION	DATE	OWN	APVD
		-	-	SEE SHEET 1	-	-	-

FEED TYPE MECHANICAL

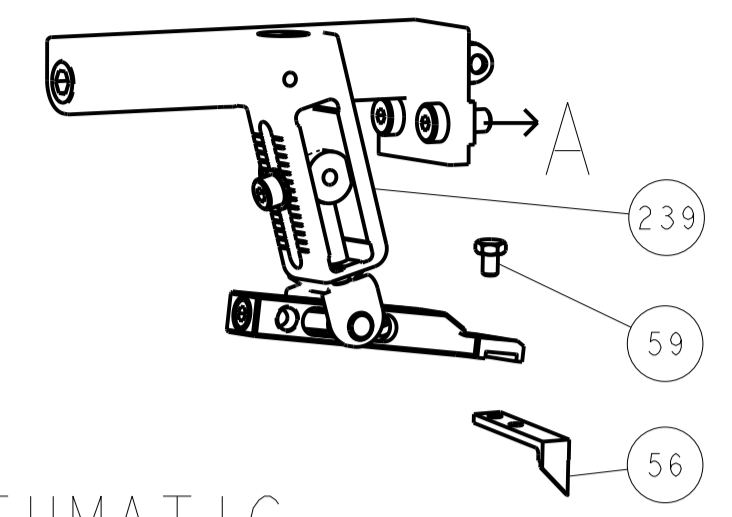

PNEUMATIC

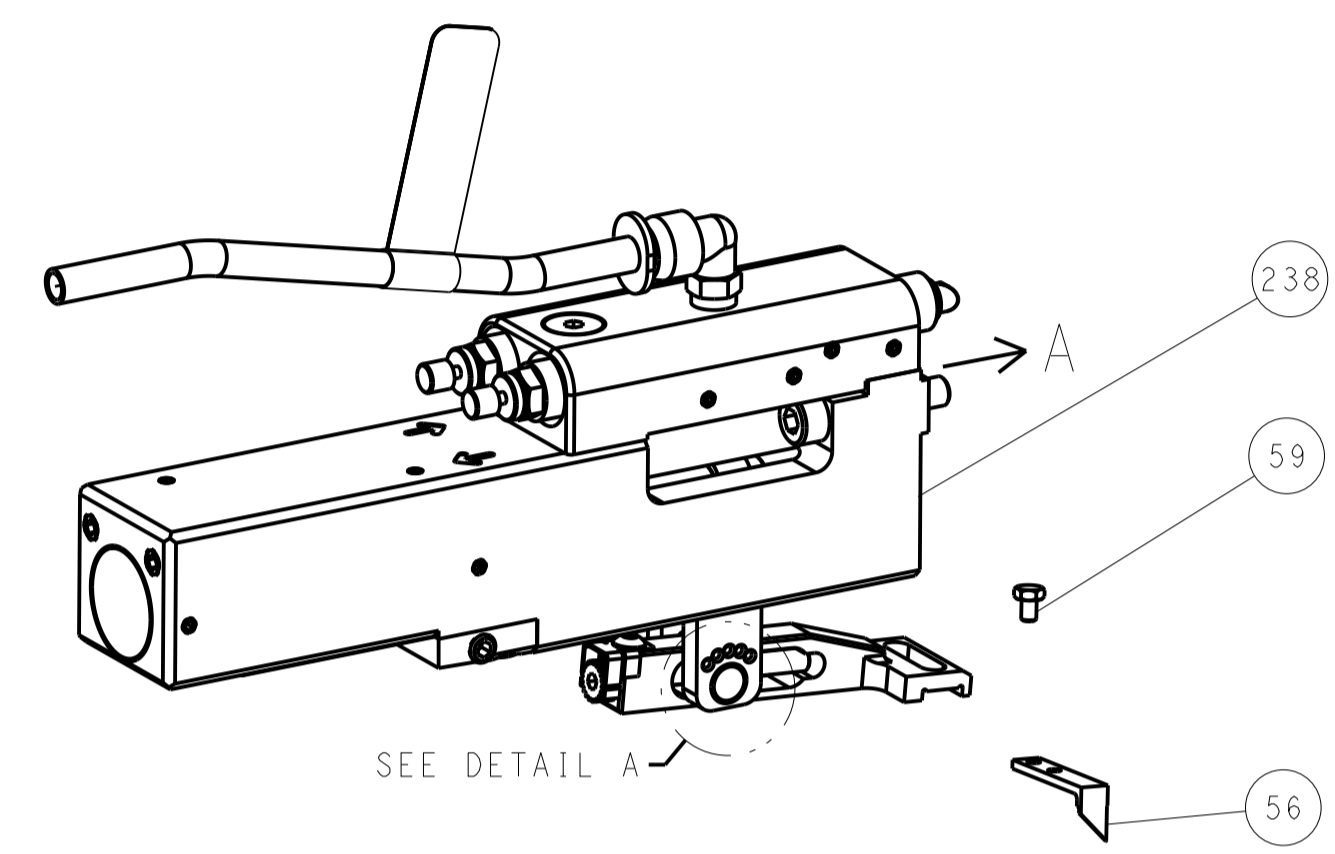

FEED SPRING SETTING POSITION (SHOWN FROM REAR SIDE)

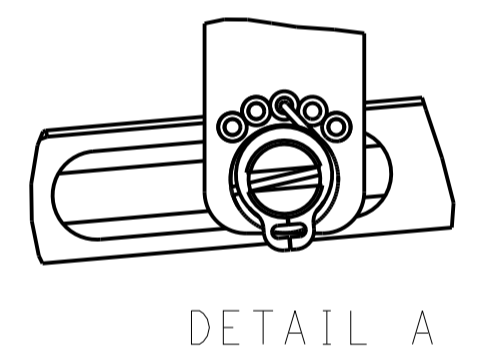

CAM POSITIONS

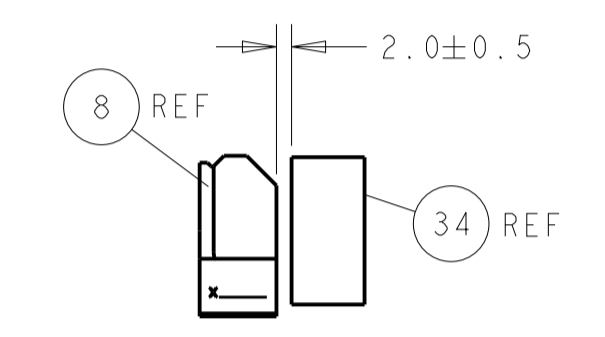
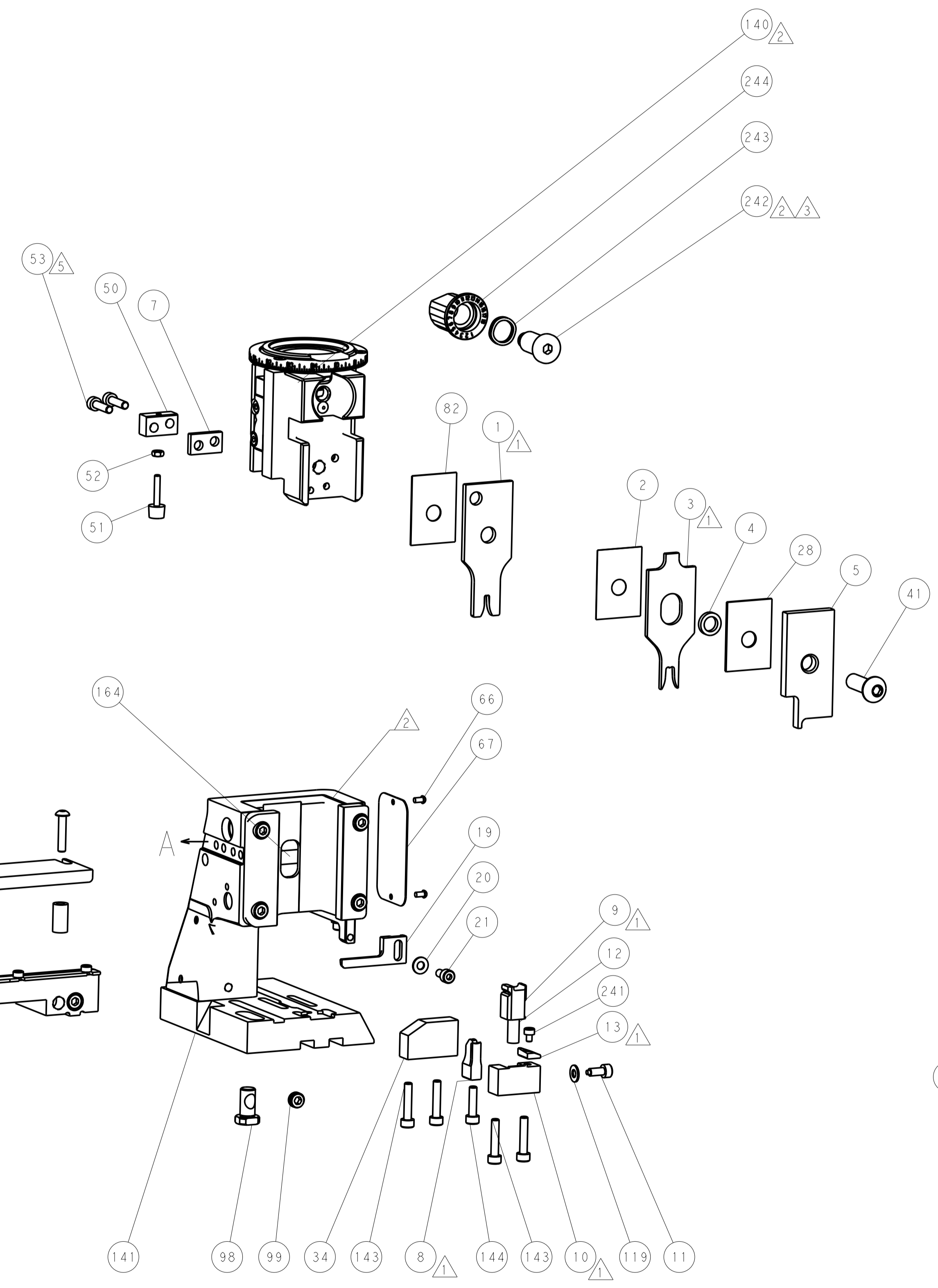
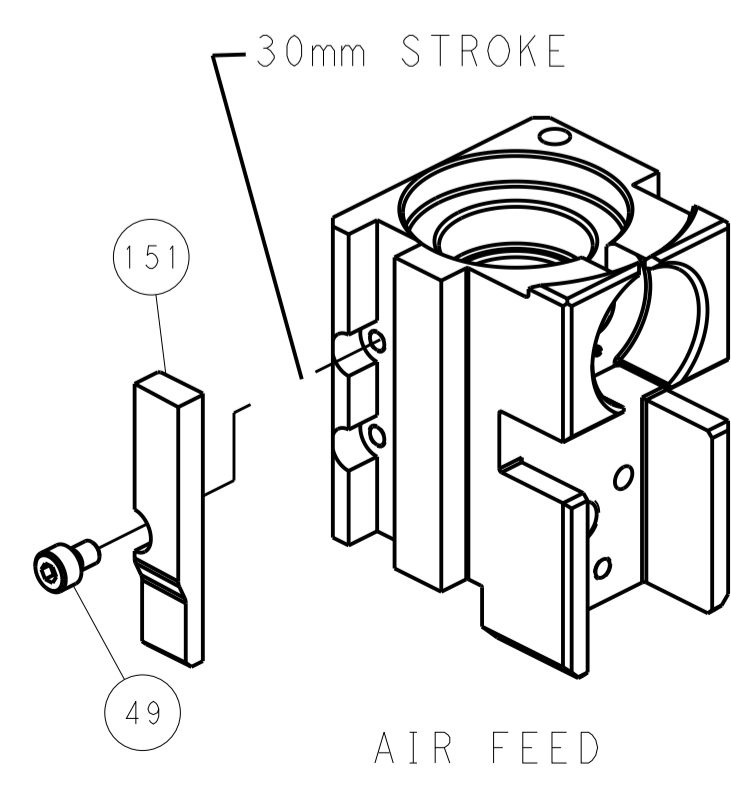
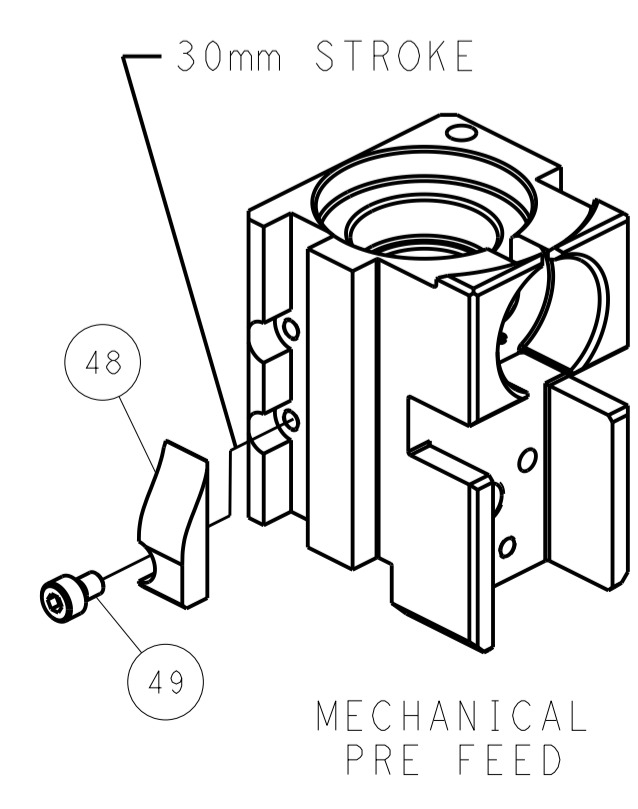
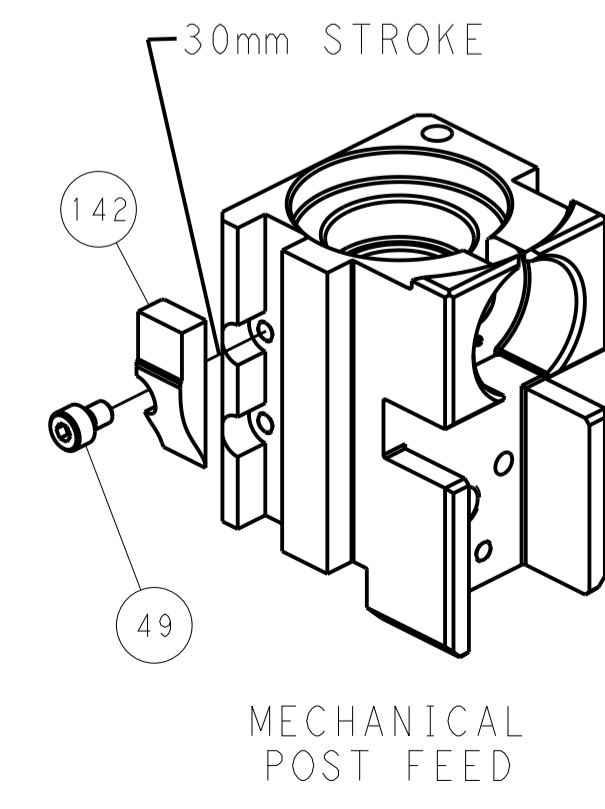

TERMINAL SUPPORT LOCATION

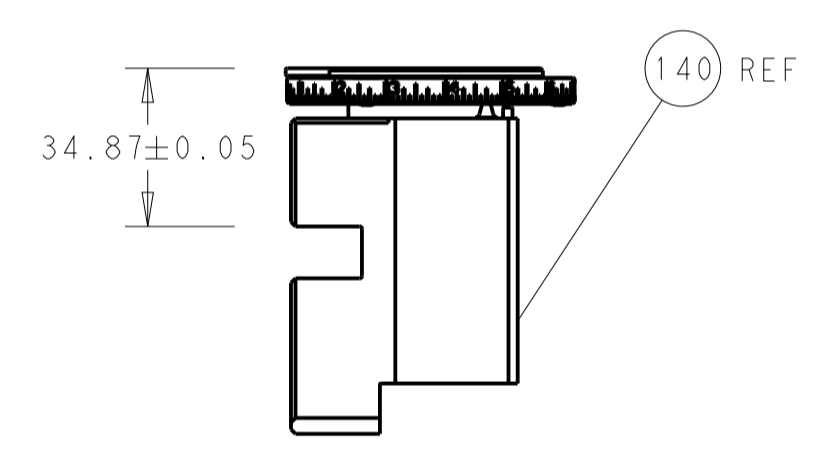

RAM SET-UP

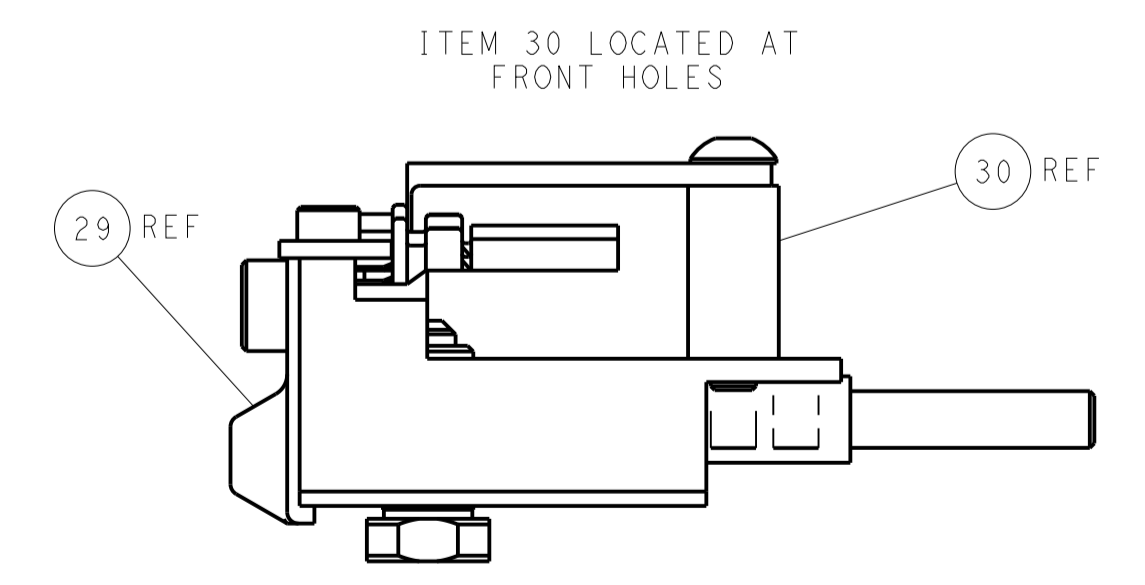

FEED TRACK POSITION GUIDE BY INSULATION BARREL

PACIFIC VERSION
 Shown on sheets 3 of 4 & 4 of 4
 (Atlantic version shown on sheets 1 of 4 & 2 of 4)

DIMENSIONS:		TOLERANCES UNLESS OTHERWISE SPECIFIED:		DWG: BOB_HIGMAN 22MAR2013		REV: G_BAILLEY 22MAR2013		NAME: M_CLEFFORD 22MAR2013		TE Connectivity Harrisburg, PA 17105-3608		
mm	0 PLC	±		0	PLC	±		PRODUCT SPEC	Ocean Side Feed Applicator			
	1 PLC	±		1	PLC	±		APPLICATION SPEC	SIZE	CAGE CODE	DRAWING NO	RESTRICTED TO
	2 PLC	±		2	PLC	±			A1	00779	2151915	
	3 PLC	±		3	PLC	±			Customer Accessible Production Drawing	SCALE	1:2	SHEET 4 OF 4
	4 PLC	±		4	PLC	±						REV C
MATERIAL	FINISH			WEIGHT								

Mouser Electronics

Authorized Distributor

Click to View Pricing, Inventory, Delivery & Lifecycle Information:

[TE Connectivity:](#)

[2-2151915-1](#)