

PART NUMBER	REVISION	DESCRIPTION	FEED TYPE
2151569-2	E	FINE CRIMP HEIGHT ADJUST	PNEUMATIC
7-2151569-2	E	PNEUMATIC AND CRIMP TOOLING KIT	PNEUMATIC
7-2151569-7	E	CRIMP TOOLING KIT	-

ATLANTIC VERSION TERMINATOR INTERFACE ADAPTER

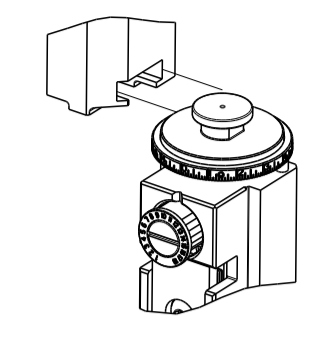

APPLICATOR DATA		
CRIMP	SIZE	TYPE
WIRE	2.03 mm [.080]	F
INSUL	6.35 mm [.250]	O

APPLICATOR INSTRUCTIONS
408-35042

TERMINAL DATA: TE TERMINAL		TE CRIMP SPECIFICATION	
TERMINAL NAME: TAB 5.8 x 0.8 mm TYP A			
WIRE STRIP LENGTH		INSULATION DIAMETER RANGE	
4.00-4.60 mm [.157-.181 IN]		Ø 6.00 MAX [.236 IN MAX]	
TERMINAL APPLICATION SPECIFICATION	114-18052		
TERMINALS APPLIED			
TE TERMINAL	TE TERMINAL	TE SEAL	SEAL INSULATION DIAMETER RANGE
964310-1	2-964310-2	963243-1	Ø 1.4-2.1 mm
		963244-1	Ø 2.2-3.0 mm

WIRE SIZE	CRIMP HEIGHT mm [INCH]	CRIMP HEIGHT REFERENCE SETTING
1.00mm2	1.56 +/- 0.05 [.061 +/- .002]	5.0
0.75mm2	1.47 +/- 0.05 [.058 +/- .002]	6.0
0.50mm2	1.38 +/- 0.05 [.054 +/- .002]	7.0



- RECOMMENDED SPARE PARTS.
- REFER TO SUPPLIED INSTRUCTION SHEET FOR CLEANING, LUBRICATION AND STORAGE OF APPLICATOR.
- APPLY PART NUMBER 2-23419-6 LOCTITE TO THREADS OF ITEMS 242.
- CRIMP HEIGHT REFERENCE SETTING WAS THE SETTING USED WHEN THE APPLICATOR WAS QUALIFIED AT THE FACTORY. ADJUSTMENT MAY BE NECESSARY WHEN RUNNING APPLICATOR IN THE FIELD.
- TERMINAL PITCH NOT COMPATIBLE WITH MECHANICAL FEED.
- APPLY TORQ-SEAL IN ALLEN SOCKET TO FILL HOLE AFTER FLAT HD HAS BEEN ADJUSTED TO CORRECT HEIGHT AT QUALIFICATION. APPLY #1-23419-5 LOC-TITE TO THREADS.
- UNLESS SPECIFIED OTHERWISE TORQUE VALUES SHALL BE USED PER DOCUMENT, 101-35000.

***WARNING**
ON INSTALLATION, SET WIRE DISC TO CRIMP HEIGHT REFERENCE SETTING FOR LARGEST WIRE SIZE. CRIMP HEIGHT REFERENCE SETTINGS GREATER THAN THE VALUE SHOWN MAY CAUSE DAMAGE TO THE CRIMP TOOLING, REFER TO THE INSTRUCTION SHEET FOR PROPER SETUP AND ADJUSTMENTS.

ATLANTIC VERSION
Shown on sheets 1 of 4 & 2 of 4
(Pacific version shown on sheets 3 of 4 & 4 of 4)

LOC	DIST	REVISIONS			
A	66	REV	DATE	BY	CHKD
		C	11MAY2018	FL	JD
		D	22JUN2019	TB	TE
		D1	02AUG2021	AJ	YY
		E	14SEP2021	JWC	GB

-	1	1	2119641-1	FEED CAM, AIR FEED	248
-	1	1	2119082-8	CAM, SNAIL, INSULATION ADJUSTMENT	244
-	1	1	2079764-1	WASHER, WAVE SPRING, CREST-TO-CREST	243
-	1	1	2119083-1	RETAINER, INSULATION DIAL	242
-	1	1	7-18023-7	SCR, SKT HD CAP M3 X 4.0	241
-	1	1	2844940-1	AIR FEED MODULE	238
-	REF	REF	994970-2	COUNTER, MAGNETIC	164
-	1	1	1-22281-8	SPRING, COMPRESSION	121
-	1	1	1-18028-2	WASHER, FLAT, REG M4	119
-	1	1	2844908-1	SCREW, LOCKING	99
-	1	1	2844907-1	POST, LOCKING	98
-	1	1	2-690438-8	FRONT STRIP GUIDE	96
-	2	2	2168083-1	SCR, SKT HD CAP, RoHS, M3 X 8.0	95
-	1	1	2168083-6	SCR, SKT HD CAP, RoHS, M5 X 65	93
-	1	1	455888-5	SPACER, CRIMPER	82
-	1	1	1803607-3	DOCUMENTATION PACKAGE	71
-	1	1	2119740-1	TAG IDENTIFICATION	67
-	2	2	2168078-1	SCREW, DRIVE, RH, RoHS, 2 x .188	66
-	2	2	2-18032-5	SCR, SET, FLT PNT, M5 X 20.0	61
-	1	1	2168083-2	SCR, SKT HD CAP, RoHS, M4 X 8.0	60
-	1	1	5-18022-5	SCR, HEX HD CAP, M4 X 6.0	59
-	1	1	985575-3	SCR, FLT SKT HD CAP M3 X 10.0	57
-	1	1	1338685-1	PAWL, FEED	56
-	4	4	2168083-3	SCR, SKT HD CAP, RoHS, M4 X 12.0	54
-	2	2	2168083-3	SCR, SKT HD CAP, RoHS, M4 X 12.0	53
-	1	1	1803382-2	HOLD DOWN, SPRING LOADED	50
-	1	1	18023-9	SCR, SKT HD CAP M4 X 6.0	49
-	1	1	1803583-9	APPLICATOR BASIC ASSEMBLY, SF	46
-	1	1	1803515-1	RAM ASSEMBLY, SF ATLANTIC	44
-	1	1	1803602-1	SCR, BHSC, RoHS (M8 X 25)	41
-	1	1	1-1752356-1	SUPPORT, TERMINAL	34
-	2	2	2079383-5	SCR, BHSC, RoHS (M4 X 20)	33
-	2	2	3-2844962-2	SPACER, CYLINDRICAL, STRIP GUIDE	30
-	1	1	1-2844938-8	PLATE, STRIP GUIDE	29
-	1	1	455888-3	SPACER, CRIMPER	28
-	2	2	22283-1	SPRING, COMPRESSION	27
-	1	1	356835-1	LEVER, DRAG RELEASE	26
-	1	1	240792-1	DRAG, TERMINAL	25
-	1	1	1320928-6	STRIP GUIDE	24
-	1	1	980371-4	SCR, SKT HD SHLDR 5.0 DIA X 6.0	23
-	1	1	2168083-2	SCR, SKT HD CAP, RoHS, M4 X 8.0	21
-	1	1	1-18028-2	WASHER, FLAT, REG M4	20
-	1	1	2119533-1	STRIPPER, SIDE FEED	19
-	1	1	2119806-1	INSERT, SHEAR	13
-	1	1	3-22280-3	SPRING, COMPRESSION	12
-	1	1	1-356885-4	STOP, SHEAR	11
-	1	1	2-2119805-1	SHEAR HOLDER, FRONT	10
-	1	1	318707-7	FLOATING SHEAR, FRONT	9
-	1	2	1-1633131-9	ANVIL, COMBINATION .080	8
-	1	1	240641-3	SPACER	7
-	-	-	-	-	6
-	1	1	2119781-6	DEPRESSOR, SHEAR	5
-	1	1	238011-4	BLOCK, CRIMPER SPACER	4
-	1	2	1-1633996-7	CRIMPER, INSULATION SPECIAL	3
-	1	1	1-455888-6	SPACER, CRIMPER	2
-	1	2	1-456405-6	CRIMPER, WIRE PREMIUM	1

DIMENSIONS:		TOLERANCES UNLESS OTHERWISE SPECIFIED:		MATERIAL:		FINISH:	
mm	0 PLC ±	1 PLC ±	2 PLC ±	3 PLC ±	4 PLC ±	ANGLES	FINISH

OWN	H. HUANG	05FEB2013	TE Connectivity
CHK	S. XI	05FEB2013	Harrisburg, PA 17105-3608
APVD	S. XI	05FEB2013	
PRODUCT SPEC	Ocean Side Feed Applicator		
APPLICATION SPEC			
SIZE	CAGE CODE	DRAWING NO	RESTRICTED TO
A1	00779	2151569	
Customer Accessible Production Drawing			SCALE 1:2 SHEET 1 OF 4 REV E

LOC	DIST	REVISIONS					
		P	LTN	DESCRIPTION	DATE	DWN	APVD
A	66	-	-	SEE SHEET 1	-	-	-

FEED TYPE

PNEUMATIC

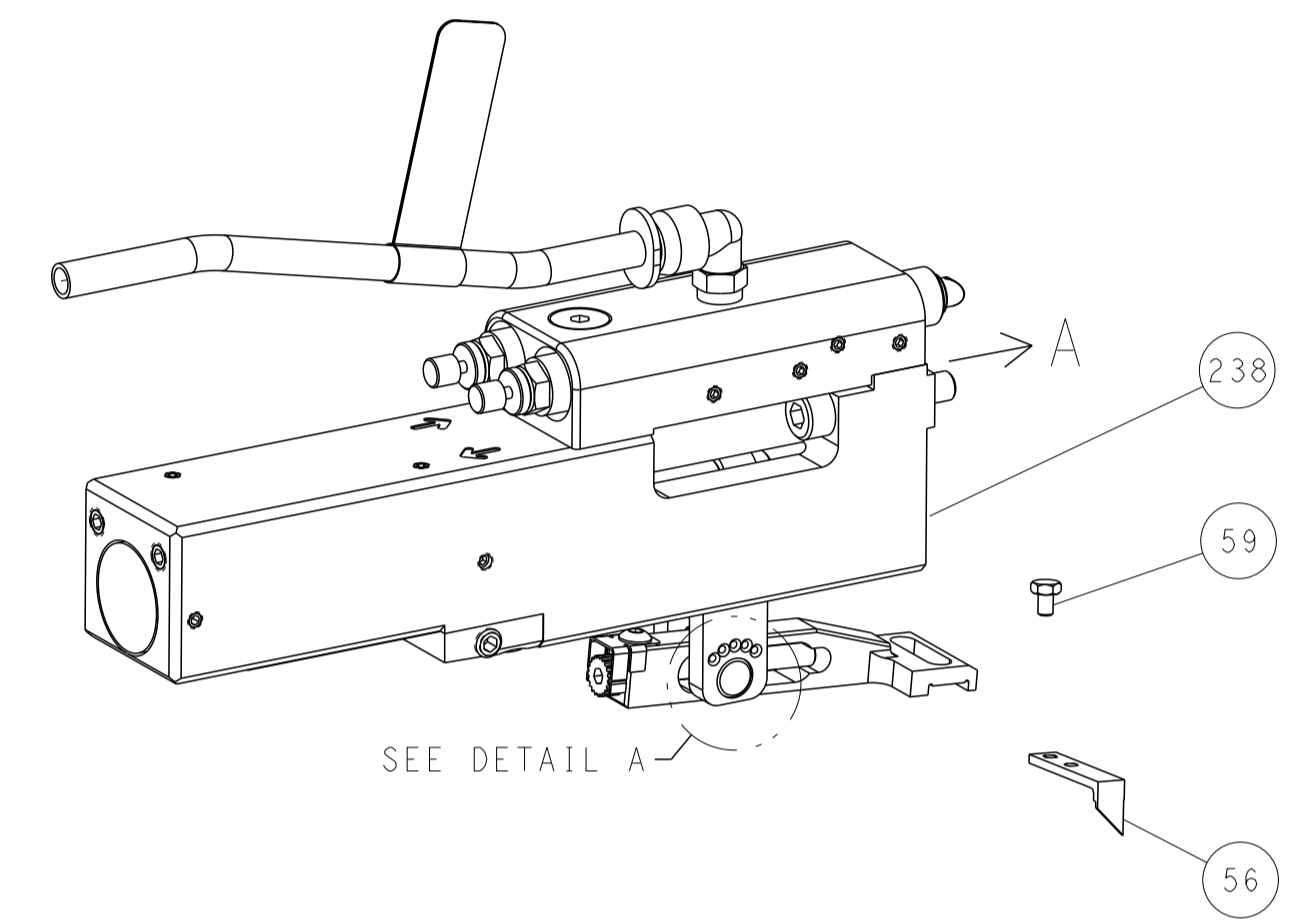

FEED SPRING SETTING POSITION (SHOWN FROM REAR SIDE)

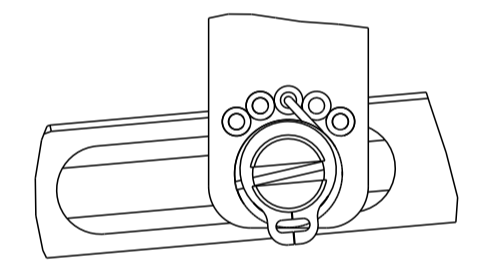

DETAIL A

CAM POSITION

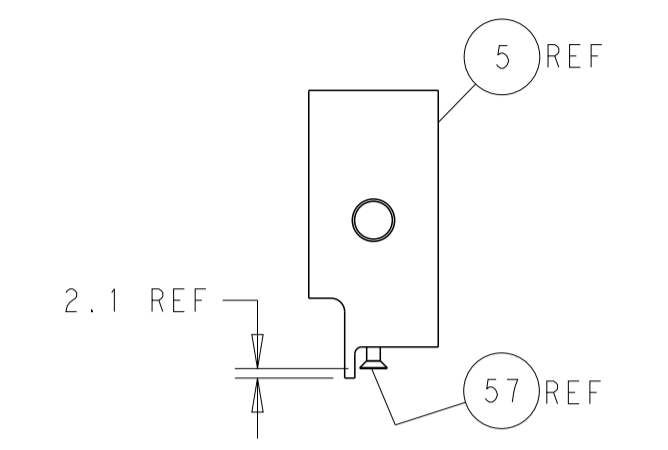
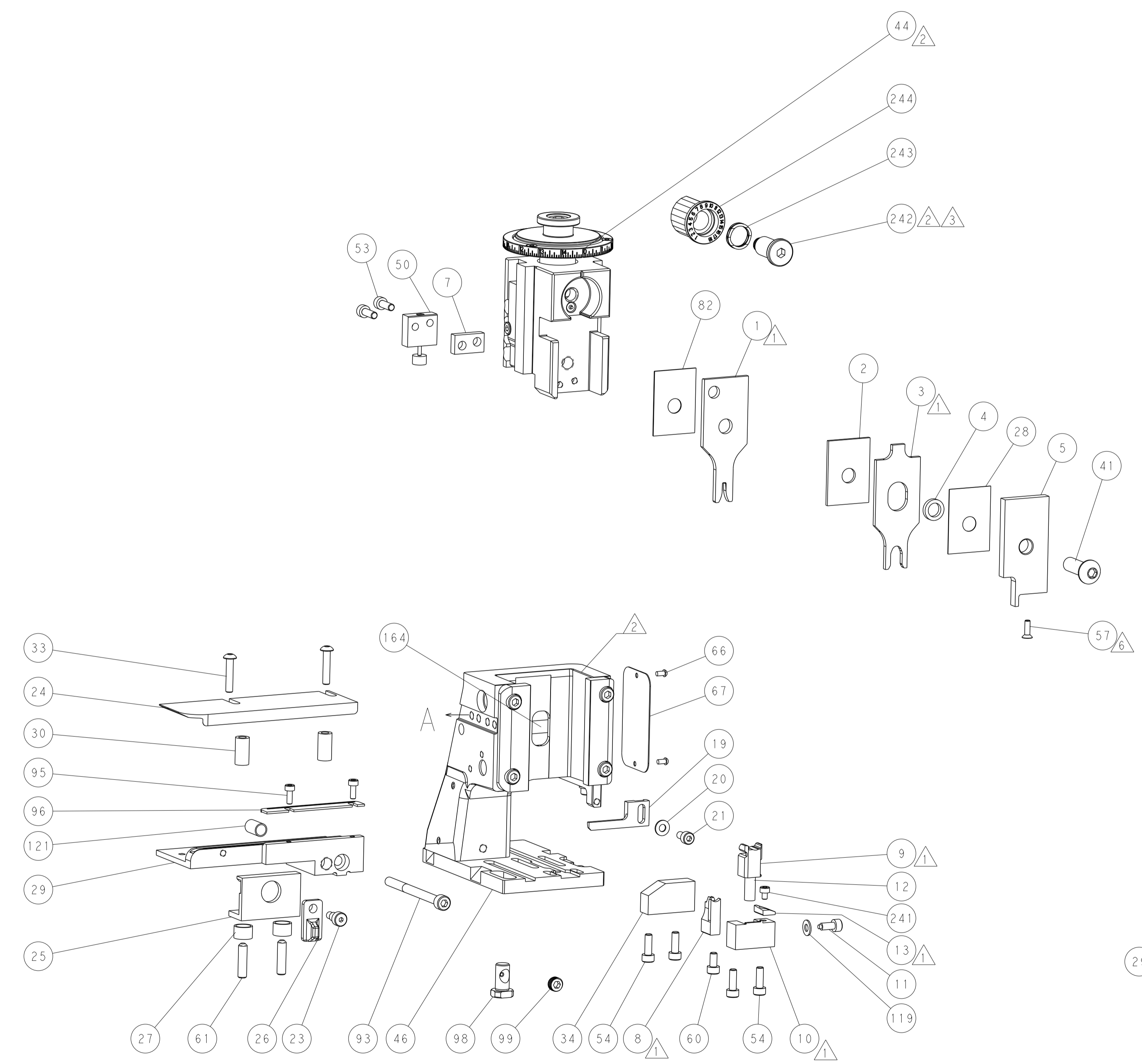
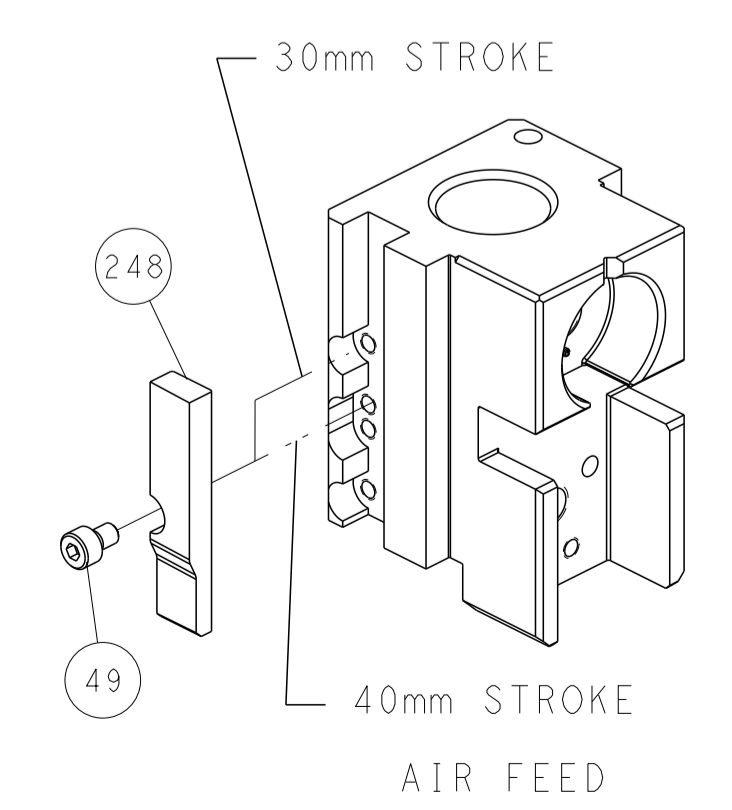

SHEAR DEPRESSOR DETAIL

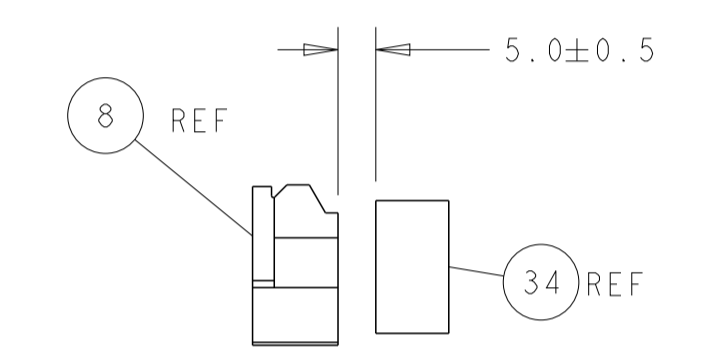

TERMINAL SUPPORT LOCATION

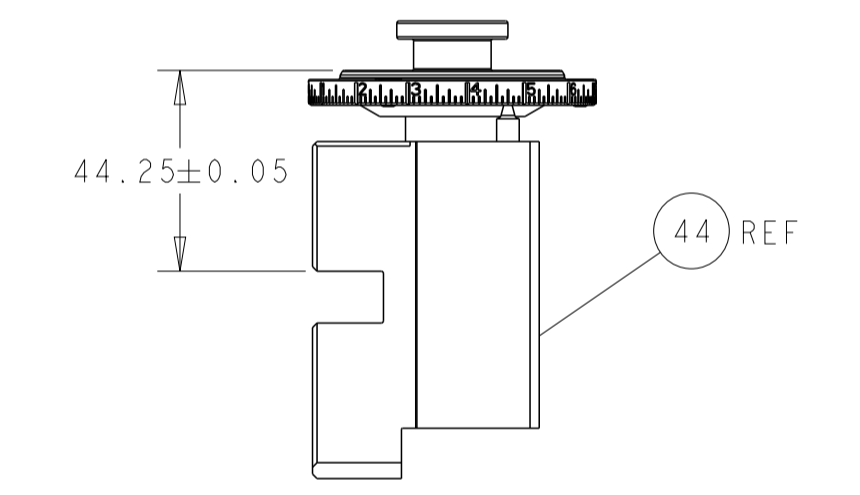

RAM SET-UP

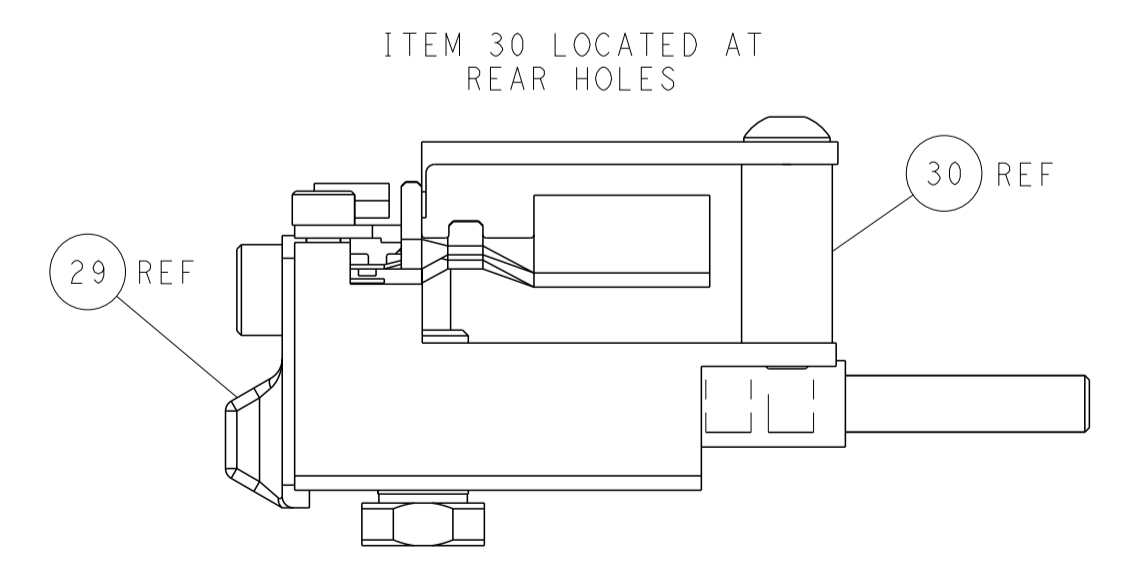

FEED TRACK POSITION
GUIDE BY INSULATION BARREL

ATLANTIC VERSION
 Shown on sheets 1 of 4 & 2 of 4
 (Pacific version shown on sheets 3 of 4 & 4 of 4)

<small>THIS DRAWING IS UNPUBLISHED. RELEASED FOR PUBLICATION. ALL RIGHTS RESERVED. THIS DRAWING IS THE PROPERTY OF TYCO ELECTRONICS CORPORATION. IT IS TO BE USED ONLY FOR THE PURPOSES SPECIFIED. IT IS NOT TO BE REPRODUCED OR TRANSMITTED IN ANY FORM OR BY ANY MEANS, ELECTRONIC OR MECHANICAL, INCLUDING PHOTOCOPYING, RECORDING, OR BY ANY INFORMATION STORAGE AND RETRIEVAL SYSTEM, WITHOUT THE WRITTEN PERMISSION OF TYCO ELECTRONICS CORPORATION.</small>		DWN R. HUANG 05FEB2013 CHK S. XI 05FEB2013 APVD S. XI 05FEB2013	NAME Ocean Side Feed Applicator
DIMENSIONS: mm 0 PLC ± 1 PLC ± 2 PLC ± 3 PLC ± 4 PLC ± ANGLES ± FINISH ±	TOLERANCES UNLESS OTHERWISE SPECIFIED: mm 0 PLC ± 1 PLC ± 2 PLC ± 3 PLC ± 4 PLC ± ANGLES ± FINISH ±	SIZE A1 00779 ©=2151569	RESTRICTED TO -
MATERIAL -		WEIGHT -	SCALE 1:2 SHEET 2 OF 4 REV E

THIS DRAWING IS UNPUBLISHED.		RELEASED FOR PUBLICATION	
COPYRIGHT 20 BY TYCO ELECTRONICS CORPORATION. ALL RIGHTS RESERVED.		20	
PART NUMBER	REVISION	DESCRIPTION	FEED TYPE
2-2151569-2	E	FINE CRIMP HEIGHT ADJUST	PNEUMATIC
7-2151569-7	E	CRIMP TOOLING KIT	-

PACIFIC VERSION TERMINATOR INTERFACE ADAPTER

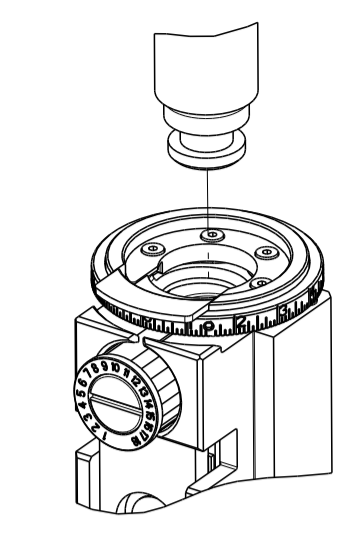

APPLICATOR DATA		
CRIMP	SIZE	TYPE
WIRE	2.03 mm [.080]	F
INSUL	6.35 mm [.250]	O
APPLICATOR INSTRUCTIONS 408-35042		

TERMINAL DATA: TE TERMINAL		TE CRIMP SPECIFICATION	
TERMINAL NAME: TAB 5.8 x 0.8 mm TYP A			
WIRE STRIP LENGTH 4.00-4.60 mm [.157-.181 IN]		INSULATION DIAMETER RANGE Ø 6.00 MAX [.236 IN MAX]	
TERMINAL APPLICATION SPECIFICATION	114-18052	-	-
TERMINALS APPLIED			
TE TERMINAL	TE TERMINAL	TE SEAL	SEAL INSULATION DIAMETER RANGE
964310-1	2-964310-2	963243-1	Ø1.4-2.1 mm
		963244-1	Ø2.2-3.0 mm

WIRE SIZE	CRIMP HEIGHT mm [INCH]	CRIMP HEIGHT REFERENCE SETTING
1.00mm2	1.56+/-0.05 [.061+/- .002]	5.0
0.75mm2	1.47+/-0.05 [.058+/- .002]	6.0
0.50mm2	1.38+/-0.05 [.054+/- .002]	7.0



- RECOMMENDED SPARE PARTS.
- REFER TO SUPPLIED INSTRUCTION SHEET FOR CLEANING, LUBRICATION AND STORAGE OF APPLICATOR.
- APPLY PART NUMBER 2-23419-6 LOCTITE TO THREADS OF ITEMS 242.
- CRIMP HEIGHT REFERENCE SETTING WAS THE SETTING USED WHEN THE APPLICATOR WAS QUALIFIED AT THE FACTORY. ADJUSTMENT MAY BE NECESSARY WHEN RUNNING APPLICATOR IN THE FIELD.
- TERMINAL PITCH NOT COMPATIBLE WITH MECHANICAL FEED.
- APPLY TORQ-SEAL IN ALLEN SOCKET TO FILL HOLE AFTER FLAT HD HAS BEEN ADJUSTED TO CORRECT HEIGHT AT QUALIFICATION. APPLY #1-23419-5 LOC-TITE TO THREADS.
- 7. UNLESS SPECIFIED OTHERWISE TORQUE VALUES SHALL BE USED PER DOCUMENT, 101-35000.

ENTRY LEVEL APPLICATOR		ITEM SUBSTITUTION LIST		
PART NUMBER	SAME AS	ITEM	ITEM DESCRIPTION	SUBSTITUTE PART NUMBER
8-2151569-1	2151569-1	1	WIRE CRIMPER	1-1803590-6
8-2151569-2	2151569-2	3	INSULATION CRIMPER	2-1803674-5
9-2151569-1	2-2151569-1	46	BASIC SUB -ASSEMBLY	1803940-9
9-2151569-2	2-2151569-2	141	BASIC SUB -ASSEMBLY	1-1803940-0
			LUBRICATOR	DELETE

***WARNING**
ON INSTALLATION, SET WIRE DISC TO CRIMP HEIGHT REFERENCE SETTING FOR LARGEST WIRE SIZE. CRIMP HEIGHT REFERENCE SETTINGS GREATER THAN THE VALUE SHOWN MAY CAUSE DAMAGE TO THE CRIMP TOOLING, REFER TO THE INSTRUCTION SHEET FOR PROPER SETUP AND ADJUSTMENTS.

PACIFIC VERSION
Shown on sheets 3 of 4 & 4 of 4
(Atlantic version shown on sheets 1 of 4 & 2 of 4)

LOC	DIST	REVISIONS					
A	66	P	LTN	DESCRIPTION	DATE	DWN	APVD
		-		SEE SHEET 1			

-	1	2119082-8	CAM, SNAIL, INSULATION ADJUSTMENT	244
-	1	2079764-1	WASHER, WAVE SPRING, CREST-TO-CREST	243
-	1	2119083-1	RETAINER, INSULATION DIAL	242
-	1	7-18023-7	SCR, SKT HD CAP M3 X 4.0	241
-	1	2844940-1	AIR FEED MODULE	238
-	REF	994970-2	COUNTER, MAGNETIC	164
-	1	2119641-2	FEED CAM, AIR FEED	151
-	1	2168083-8	SCR, SKT HD CAP, RoHS, M4 X 16	144
-	4	2168083-9	SCR, SKT HD CAP, RoHS, M4 X 20	143
-	1	1-1803583-0	APPLICATOR BASIC ASSEMBLY, SF	141
-	1	1803516-1	RAM ASSEMBLY, SF PACIFIC	140
-	1	1-22281-8	SPRING, COMPRESSION	121
-	1	1-18028-2	WASHER, FLAT, REG M4	119
-	1	2844908-1	SCREW, LOCKING	99
-	1	2844907-1	POST, LOCKING	98
-	1	2-690438-8	FRONT STRIP GUIDE	96
-	2	2168083-1	SCR, SKT HD CAP, RoHS, M3 X 8.0	95
-	1	2168083-6	SCR, SKT HD CAP, RoHS, M5 X 65	93
-	1	455888-5	SPACER, CRIMPER	82
-	1	1803607-3	DOCUMENTATION PACKAGE	71
-	1	2119740-1	TAG, IDENTIFICATION	67
-	2	2168078-1	SCREW, DRIVE, RH, RoHS, 2 x .188	66
-	2	2-18032-5	SCR, SET, FLT PNT, M5 X 20.0	61
-	1	5-18022-5	SCR, HEX HD CAP, M4 X 6.0	59
-	1	985575-3	SCR, FLT SKT HD CAP M3 X 10.0	57
-	1	1338685-1	PAWL, FEED	56
-	2	2168083-3	SCR, SKT HD CAP, RoHS, M4 X 12.0	53
-	1	1803382-2	HOLD DOWN, SPRING LOADED	50
-	1	18023-9	SCR, SKT HD CAP M4 X 6.0	49
-	1	1803602-1	SCR, BHSC, RoHS (M8 X 25)	41
-	1	1-1752356-1	SUPPORT, TERMINAL	34
-	2	2079383-5	SCR, BHSC, RoHS (M4 X 20)	33
-	2	3-2844962-2	SPACER, CYLINDRICAL, STRIP GUIDE	30
-	1	1-2844938-8	PLATE, STRIP GUIDE	29
-	1	455888-3	SPACER, CRIMPER	28
-	2	22283-1	SPRING, COMPRESSION	27
-	1	356835-1	LEVER, DRAG RELEASE	26
-	1	240792-1	DRAG, TERMINAL	25
-	1	1320928-6	STRIP GUIDE	24
-	1	980371-4	SCR, SKT HD SHLDR 5.0 DIA X 6.0	23
-	1	2168083-2	SCR, SKT HD CAP, RoHS, M4 X 8.0	21
-	1	1-18028-2	WASHER, FLAT, REG M4	20
-	1	2119533-1	STRIPPER, SIDE FEED	19
-	1	2119806-1	INSERT, SHEAR	13
-	1	3-22280-3	SPRING, COMPRESSION	12
-	1	1-356885-4	STOP, SHEAR	11
-	1	2-2119805-1	SHEAR HOLDER, FRONT	10
-	1	318707-7	FLOATING SHEAR, FRONT	9
-	1	9-1633131-9	ANVIL, COMBINATION .080	8
-	1	240641-3	SPACER	7
-	-	-	-	6
-	1	2119781-6	DEPRESSOR, SHEAR	5
-	1	238011-4	BLOCK, CRIMPER SPACER	4
-	1	6-1633996-7	CRIMPER, INSULATION SPECIAL	3
-	1	1-455888-6	SPACER, CRIMPER	2
-	1	1-456405-6	CRIMPER, WIRE PREMIUM	1
-77	-22	PART NO	DESCRIPTION	ITEM NO

<small>THIS DRAWING IS UNPUBLISHED. TO BE RELEASED FOR PUBLICATION, CONTACT THE APPLICATOR'S DISTRIBUTION DEPARTMENT. TOLERANCES UNLESS OTHERWISE SPECIFIED: DIMENSIONS: mm. ANGLES: FINISH: MATERIAL: .</small>		DWN: H. HUANG 05FEB2013 CHK: S. XI 05FEB2013 APVD: S. XI 05FEB2013	TE Connectivity Harrisburg, PA 17105-3608
DIMENSIONS: mm 0 PLC ± 1 PLC ± 2 PLC ± 3 PLC ± 4 PLC ± ANGLES: FINISH: MATERIAL: .		PRODUCT SPEC APPLICATION SPEC	NAME: Ocean Side Feed Applicator SIZE: A1 CAGE CODE: 00779 DRAWING NO: ©=2151569 RESTRICTED TO:
WEIGHT: . SCALE: 1:2 SHEET 3 OF 4 REV E		Customer Accessible Production Drawing	

LOC	DIST	REVISIONS					
		P	LTN	DESCRIPTION	DATE	DWN	APVD
A	66	-	-	SEE SHEET 1	-	-	-

FEED TYPE

PNEUMATIC

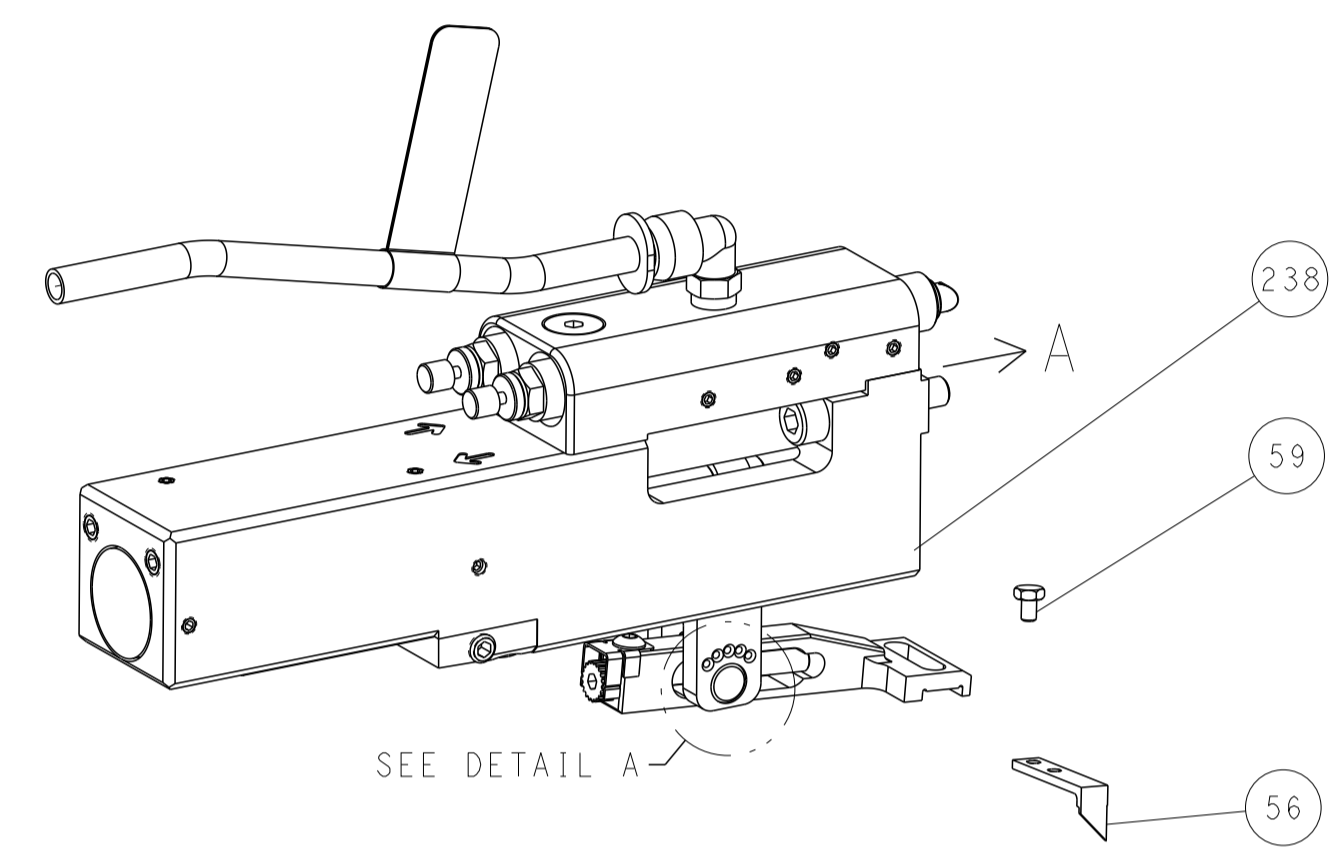

FEED SPRING SETTING POSITION (SHOWN FROM REAR SIDE)

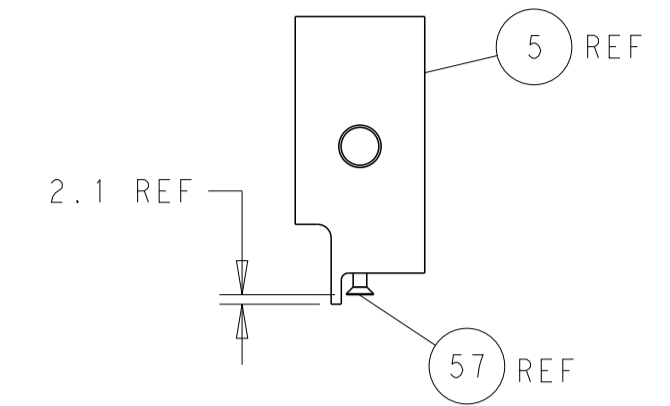
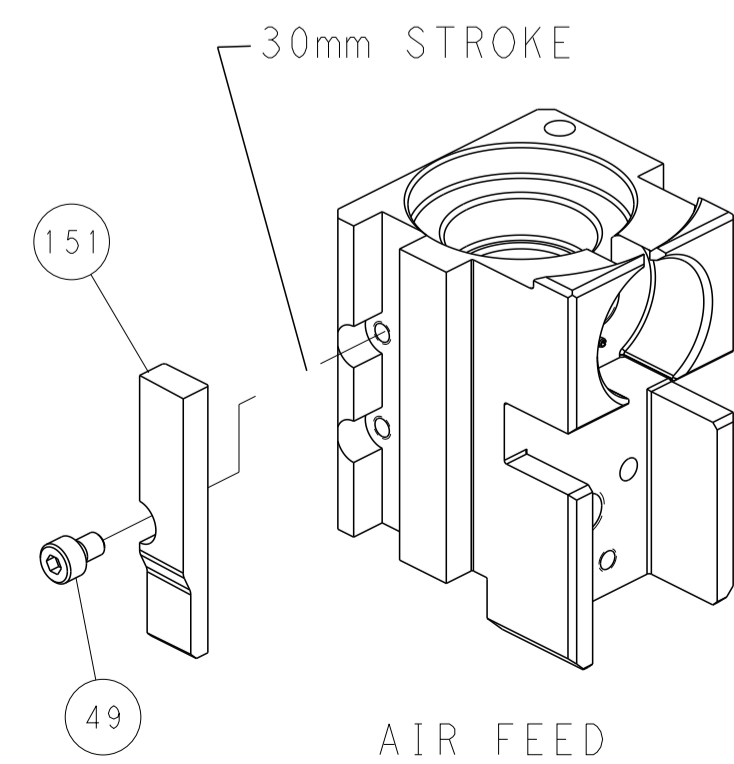
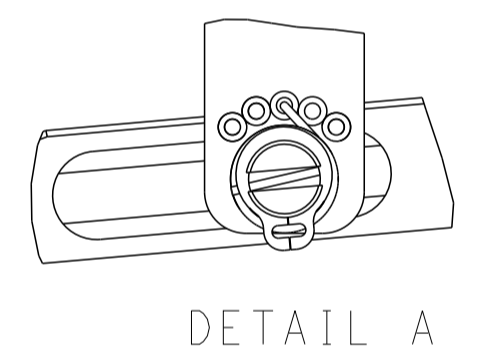

SHEAR DEPRESSOR DETAIL

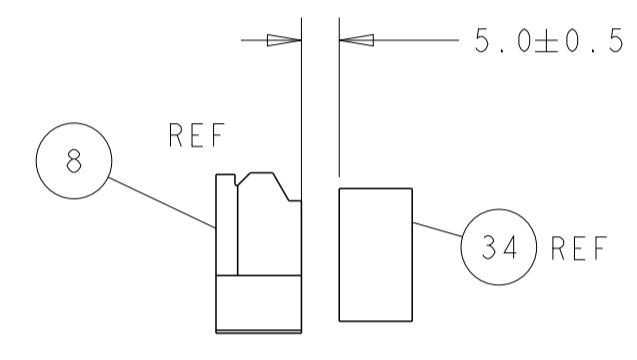

TERMINAL SUPPORT LOCATION

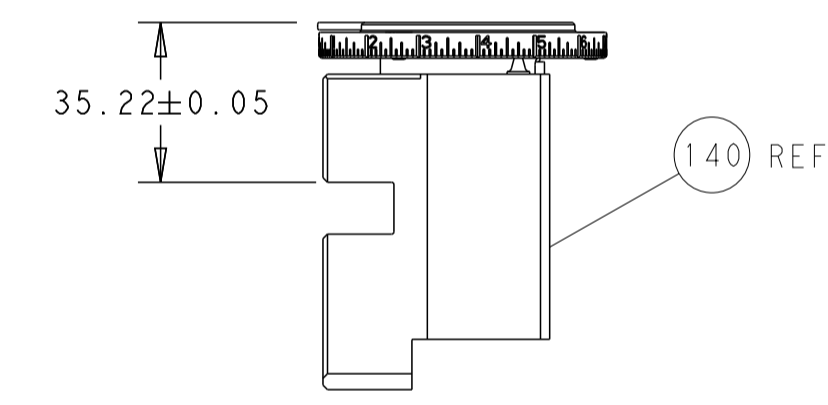

RAM SET-UP

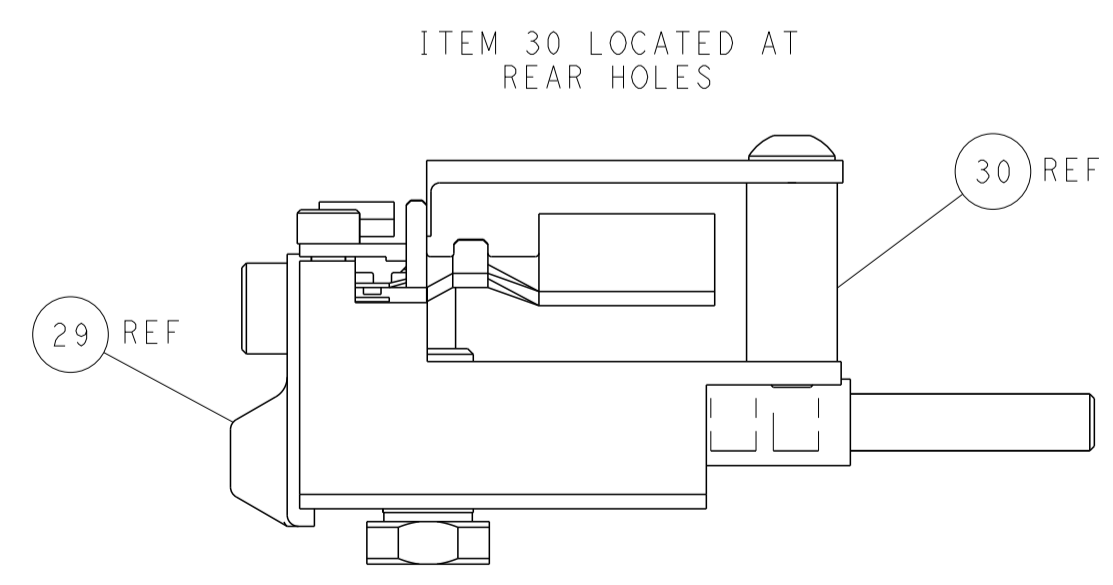

FEED TRACK POSITION GUIDE BY INSULATION BARREL

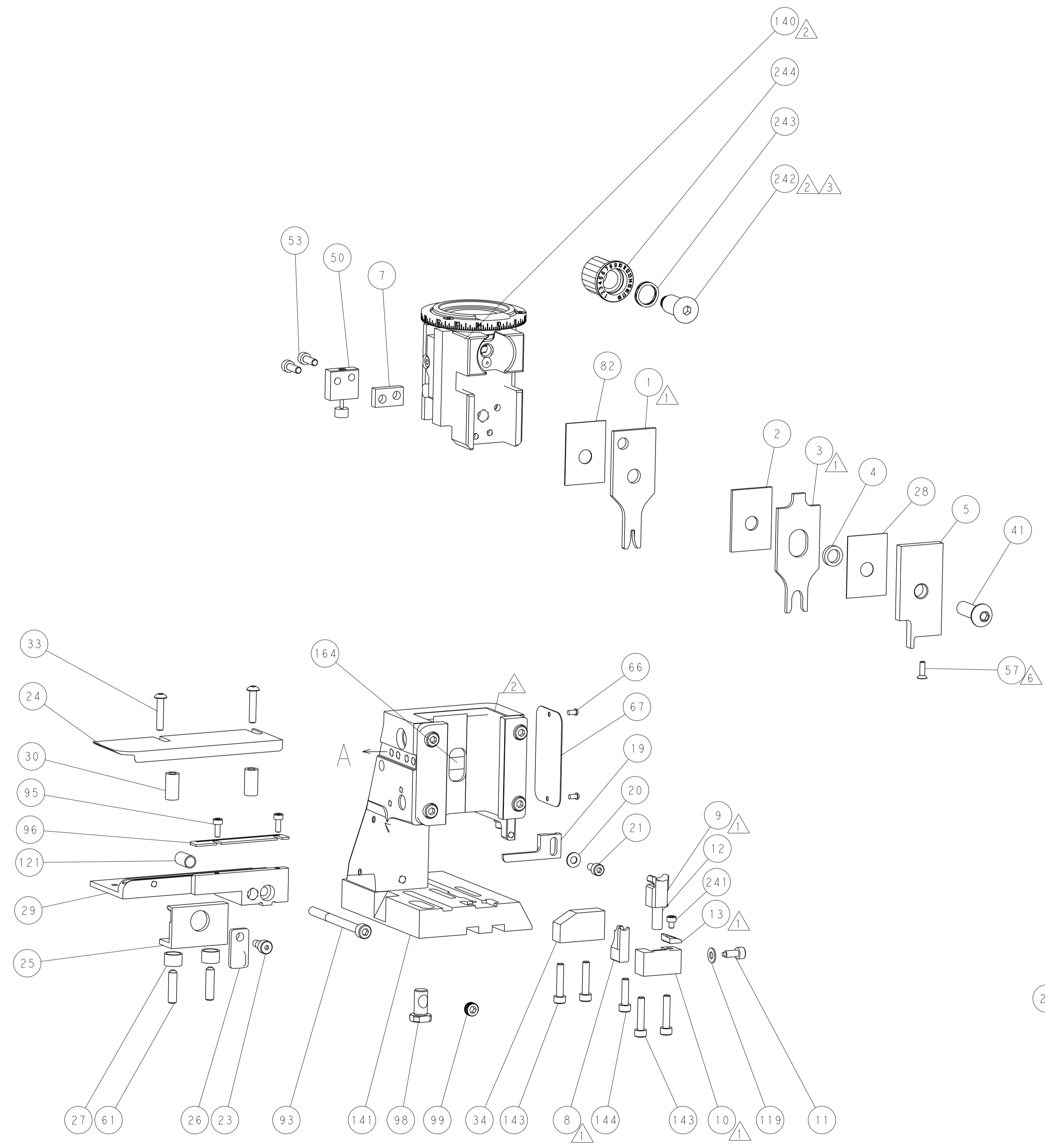

PACIFIC VERSION
 Shown on sheets 3 of 4 & 4 of 4
 (Atlantic version shown on sheets 1 of 4 & 2 of 4)

<small>THIS DRAWING IS UNPUBLISHED. RELEASED FOR PUBLICATION. IT IS THE PROPERTY OF TYCO ELECTRONICS CORPORATION. IT IS TO BE USED ONLY FOR THE PURPOSES AND IN THE MANNER SPECIFIED BY THE USER. NO PART OF THIS DRAWING IS TO BE REPRODUCED OR TRANSMITTED IN ANY FORM OR BY ANY MEANS, ELECTRONIC OR MECHANICAL, INCLUDING PHOTOCOPYING, RECORDING, OR BY ANY INFORMATION STORAGE AND RETRIEVAL SYSTEM, WITHOUT PERMISSION IN WRITING FROM TYCO ELECTRONICS CORPORATION.</small>		DWN: H. HUANG 05FEB2013 CHK: S. XI 05FEB2013 APVD: S. XI 05FEB2013	TE Connectivity Harrisburg, PA 17105-3608
DIMENSIONS: mm TOLERANCES UNLESS OTHERWISE SPECIFIED: 0 PLC ± 1 PLC ± 2 PLC ± 3 PLC ± 4 PLC ± ANGLES ± FINISH ±		NAME: Ocean Side Feed Applicator PRODUCT SPEC: APPLICATION SPEC: SIZE: A1 CAGE CODE: 00779 DRAWING NO: 2151569	RESTRICTED TO:
MATERIAL:		WEIGHT:	SCALE: 1:2 SHEET: 4 OF 4 REV: E

Mouser Electronics

Authorized Distributor

Click to View Pricing, Inventory, Delivery & Lifecycle Information:

[TE Connectivity:](#)

[2151569-2](#)