

PART NUMBER	REVISION	DESCRIPTION	FEED TYPE
2151300-1	P	FINE CRIMP HEIGHT ADJUST	MECHANICAL
2151300-2	P	FINE CRIMP HEIGHT ADJUST	PNEUMATIC
3-2151300-2	P	FINE CRIMP HEIGHT ADJUST	DOUBLE ACTING PNEUMATIC WITH SENSORS
5-2151300-1	P	SEAL STRIPPER CRIMPER TERMINATING UNIT	MECHANICAL
5-2151300-2	P	SEAL STRIPPER CRIMPER TERMINATING UNIT	PNEUMATIC
7-2151300-1	P	MECHANICAL AND CRIMP TOOLING KIT	MECHANICAL
7-2151300-2	P	PNEUMATIC AND CRIMP TOOLING KIT	PNEUMATIC
7-2151300-7	N	CRIMP TOOLING KIT	-

ATLANTIC VERSION TERMINATOR INTERFACE ADAPTER

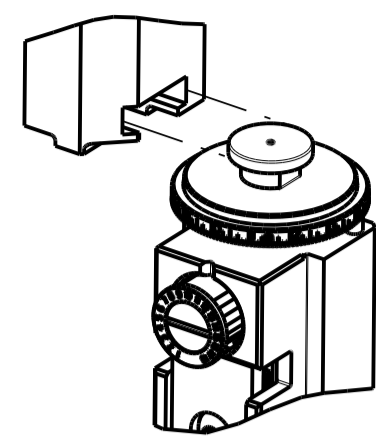

APPLICATOR DATA		
CRIMP	SIZE	TYPE
WIRE	1.40 mm [.055]	F
INSUL	1.83 mm [.072]	SPECIAL

APPLICATOR INSTRUCTIONS 408-35042

TERMINAL DATA: TE TERMINAL TE CRIMP SPECIFICATION			
TERMINAL NAME: TAB CONTACT 1.2 MM			
WIRE STRIP LENGTH 3.30-3.90 mm [1.30-.154 IN]		INSULATION DIAMETER RANGE Ø1.40-1.90 mm [.055-.075 IN]	
TERMINAL APPLICATION SPECIFICATION	114-18464	-	-
TERMINALS APPLIED			
TE TERMINAL	TE TERMINAL	TE TERMINAL	TE TERMINAL
1418760-1	1418760-2	1418760-3	5-1418760-1
5-1418760-2	5-1418760-3		

WIRE SIZE	CRIMP HEIGHT mm [INCH]	CRIMP HEIGHT REFERENCE SETTING
0.75mm2	1.05 +/- 0.03 [.041 +/- .001]	6.7
0.5mm2 OR 20 AWG	0.93 +/- 0.03 [.037 +/- .001]	7.9

***WARNING**
ON INSTALLATION, SET WIRE DISC TO CRIMP HEIGHT REFERENCE SETTING FOR LARGEST WIRE SIZE. CRIMP HEIGHT REFERENCE SETTINGS GREATER THAN THE VALUE SHOWN MAY CAUSE DAMAGE TO THE CRIMP TOOLING, REFER TO THE INSTRUCTION SHEET FOR PROPER SETUP AND ADJUSTMENTS.

- 1. RECOMMENDED SPARE PARTS
- 2. REFER TO SUPPLIED INSTRUCTION SHEET FOR CLEANING, LUBRICATION AND STORAGE OF APPLICATOR.
- 3. APPLY PART NUMBER 1-23419-5 LOCTITE TO THREADS OF ITEMS 180. APPLY PART NUMBER 2-23419-6 LOCTITE TO THREADS OF ITEM 242.
- 4. CRIMP HEIGHT REFERENCE SETTING WAS THE SETTING USED WHEN THE APPLICATOR WAS QUALIFIED AT THE FACTORY. ADJUSTMENT MAY BE NECESSARY WHEN RUNNING APPLICATOR IN THE FIELD.
- 5. THIS APPLICATOR IS EQUIPPED WITH THE DOUBLE ACTING FEED WITH SENSORS AND IS APPLICATION SPECIFIC AND DOES NOT REQUIRE ITEMS 49 & 248.
- 6. TERMINAL LUBRICANT IS RECOMMENDED.
- 7. UNLESS SPECIFIED OTHERWISE TORQUE VALUES SHALL BE USED PER DOCUMENT, 101-35000.

LOC	DIST	REVISIONS			
A	66	REV	DATE	BY	CHKD
M	ECR-19-005482	04APR2019	JAH	CT	
N	ECR-20-015917	09NOV2020	JWC	GB	
N1	ECR-21-000640	19JAN2021	FJ	YY	
P	ECR-21-006313	17JUN2021	FZ	TE	

-	-	-	1	1	-	-	-	1803515-3	RAM ASSEMBLY, SF ATLANTIC	293	
-	-	-	1	1	-	-	-	2-1803583-1	APPLICATOR BASIC ASSEMBLY, SF	292	
-	-	-	-	-	1	-	-	2844950-1	AIR FEED MODULE	290	
-	2	2	2	2	2	2	2	2168083-1	SCR, SKT HD CAP, RoHS, M3 X 8.0	269	
-	1	1	1	1	1	1	1	1-1633782-1	FENCE	267	
5	-	-	1	-	-	1	-	2119641-1	FEED CAM, AIR FEED	248	
-	1	1	1	1	1	1	1	2119082-5	CAM, SNAIL, INSULATION ADJUSTMENT	244	
-	1	1	1	1	1	1	1	2079764-1	WASHER, WAVE SPRING, CREST-TO-CREST	243	
3	-	1	1	1	1	1	1	2119083-1	RETAINER, INSULATION DIAL	242	
-	1	1	1	1	1	1	1	7-18023-7	SCR, SKT HD CAP M3 X 4.0	241	
-	-	1	-	1	-	-	1	2119580-1	MECHANICAL FEED ASSEMBLY	239	
-	1	-	1	-	-	1	-	2844940-1	AIR FEED MODULE	238	
-	-	-	1	1	-	-	-	4-1722335-3	STRIPPER, SIDE FEED	182	
-	-	-	1	1	-	-	-	1-5018030-0	NUT, HEX, REG, RoHS, M3.5	181	
3	-	-	1	1	-	-	-	1-1752354-8	STANDOFF, HOLD-DOWN	180	
-	-	-	1	1	-	-	-	9931111-1	PIN, SLOTTED SPRING 3.0 X 20.0	177	
-	-	-	1	1	-	-	-	5-22280-0	SPRING, COMPRESSION	176	
-	-	-	1	1	-	-	-	1752353-3	GUIDE PIN, HOLDDOWN	175	
-	-	-	1	1	-	-	-	1901680-2	GUIDE PIN, HOLDDOWN	174	
-	REF	REF	REF	REF	REF	REF	REF	994970-2	COUNTER, MAGNETIC	164	
6	-	1	1	1	1	1	1	2119955-1	ASSY, LUBRICATOR, SIDE FEED	113	
-	1	1	1	1	1	1	1	2844908-1	SCREW, LOCKING	99	
-	1	1	1	1	1	1	1	2844907-1	POST, LOCKING	98	
-	1	1	1	1	1	1	1	455888-5	SPACER, CRIMPER	82	
-	1	1	1	1	1	1	1	5-547505-2	SPRING, COMPRESSION	77	
-	1	1	1	1	1	1	1	854769-5	HOLDER, INS	74	
-	1	1	1	1	1	1	1	1803607-3	DOCUMENTATION PACKAGE	71	
-	1	1	1	1	1	1	1	2119740-1	TAG, IDENTIFICATION	67	
-	2	2	2	2	2	2	2	2168078-1	SCREW, DRIVE, RH, RoHS, 2 x .188	66	
-	1	1	1	1	1	1	1	2168083-2	SCR, SKT HD CAP, RoHS, M4 X 8.0	60	
-	1	1	1	1	1	1	1	5-18022-5	SCR, HEX HD CAP, M4 X 6.0	59	
-	1	1	1	1	1	1	1	21028-2	PIN, SLOTTED SPRING .062 X .250	58	
-	1	1	1	1	1	1	1	1338685-1	PAWL, FEED	56	
-	4	4	4	4	4	4	4	2168083-3	SCR, SKT HD CAP, RoHS, M4 X 12.0	54	
-	2	2	2	2	2	2	2	2-2168083-5	SCR, SKT HD CAP, RoHS, M4 X 14	53	
-	1	1	1	1	1	1	1	1803382-6	HOLD DOWN, SPRING LOADED	50	
5	-	1	2	1	2	-	1	2	18023-9	SCR, SKT HD CAP M4 X 6.0	49
-	-	1	-	1	-	-	1	2119652-1	FEED CAM, PRE FEED	48	
-	-	1	-	1	-	-	1	2119653-1	FEED CAM, POST FEED	47	
-	1	1	-	-	-	1	1	1803583-9	APPLICATOR BASIC ASSEMBLY, SF	46	
-	1	1	-	-	-	1	1	1803515-1	RAM ASSEMBLY, SF ATLANTIC	44	
-	1	1	1	1	1	1	1	1803602-1	SCR, BHSC, RoHS (M8 X 25)	41	
-	1	1	1	1	1	1	1	2-1752356-0	SUPPORT, TERMINAL	34	
-	2	2	2	2	2	2	2	2079383-5	SCR, BHSC, RoHS (M4 X 20)	33	
-	2	2	2	2	2	2	2	2-2844962-6	SPACER, CYLINDRICAL, STRIP GUIDE	30	
-	1	1	1	1	1	1	1	2844992-2	ASSEMBLY, STRIP GUIDE	29	
-	1	1	1	1	1	1	1	455888-3	SPACER, CRIMPER	28	
-	1	1	1	1	1	1	1	1320928-6	STRIP GUIDE	24	
-	1	1	-	-	1	1	1	2168083-2	SCR, SKT HD CAP, RoHS, M4 X 8.0	21	
-	2	2	1	1	2	2	2	1-18028-2	WASHER, FLAT, REG M4	20	
-	1	1	-	-	1	1	1	2119533-1	STRIPPER, SIDE FEED	19	
1	-	1	1	1	1	1	1	2119806-1	INSERT, SHEAR	13	
-	1	1	1	1	1	1	1	3-22280-3	SPRING, COMPRESSION	12	
-	1	1	1	1	1	1	1	1-356885-4	STOP, SHEAR	11	
1	-	1	1	1	1	1	1	2119805-1	SHEAR HOLDER, FRONT	10	
1	-	1	1	1	1	1	1	1633861-4	SHEAR, FLOATING	9	
1	2	2	1	1	1	1	1	1-1333231-3	ANVIL, COMBINATION, SPECIAL	8	
-	1	1	1	1	1	1	1	5-240641-0	SPACER	7	
-	1	1	1	1	1	1	1	1-2119780-1	DEPRESSOR, SHEAR	5	
-	1	1	1	1	1	1	1	4-238011-2	BLOCK, CRIMPER SPACER	4	
1	2	2	1	1	1	1	1	1633989-1	CRIMPER, INSULATION, SPECIAL	3	
1	2	2	1	1	1	1	1	3-1633730-2	CRIMPER, WIRE	1	

ATLANTIC VERSION
Shown on sheets 1 of 4 & 2 of 4
(Pacific version shown on sheets 3 of 4 & 4 of 4)

DIMENSIONS:		TOLERANCES UNLESS OTHERWISE SPECIFIED:		MATERIAL:		FINISH:	
mm	0 PLC ±	1 PLC ±	2 PLC ±	3 PLC ±	4 PLC ±	ANGLES ±	

OWN	C. MOYER	24AUG2011	TE Connectivity
CHK	T. ELBIN	24AUG2011	Harrisburg, PA 17105-3608
APVD	T. ELBIN	24AUG2011	
PRODUCT SPEC	Ocean Side Feed Applicator		
APPLICATION SPEC	-		
SIZE	CAGE CODE	DRAWING NO	RESTRICTED TO
A1	00779	2151300	-
Customer Accessible Production Drawing			SCALE 1:2 SHEET 1 OF 4 REV P

LOC		DIST		REVISIONS			
A	66	P	LTM	DESCRIPTION	DATE	OWN	APVD
		-		SEE SHEET 1			

FEED TYPE MECHANICAL

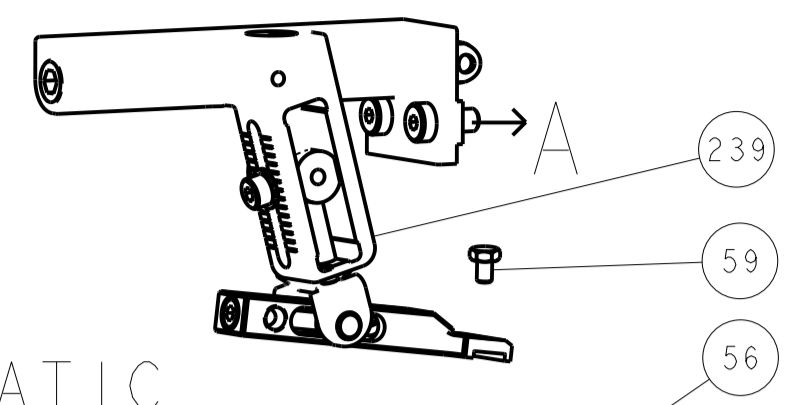

PNEUMATIC

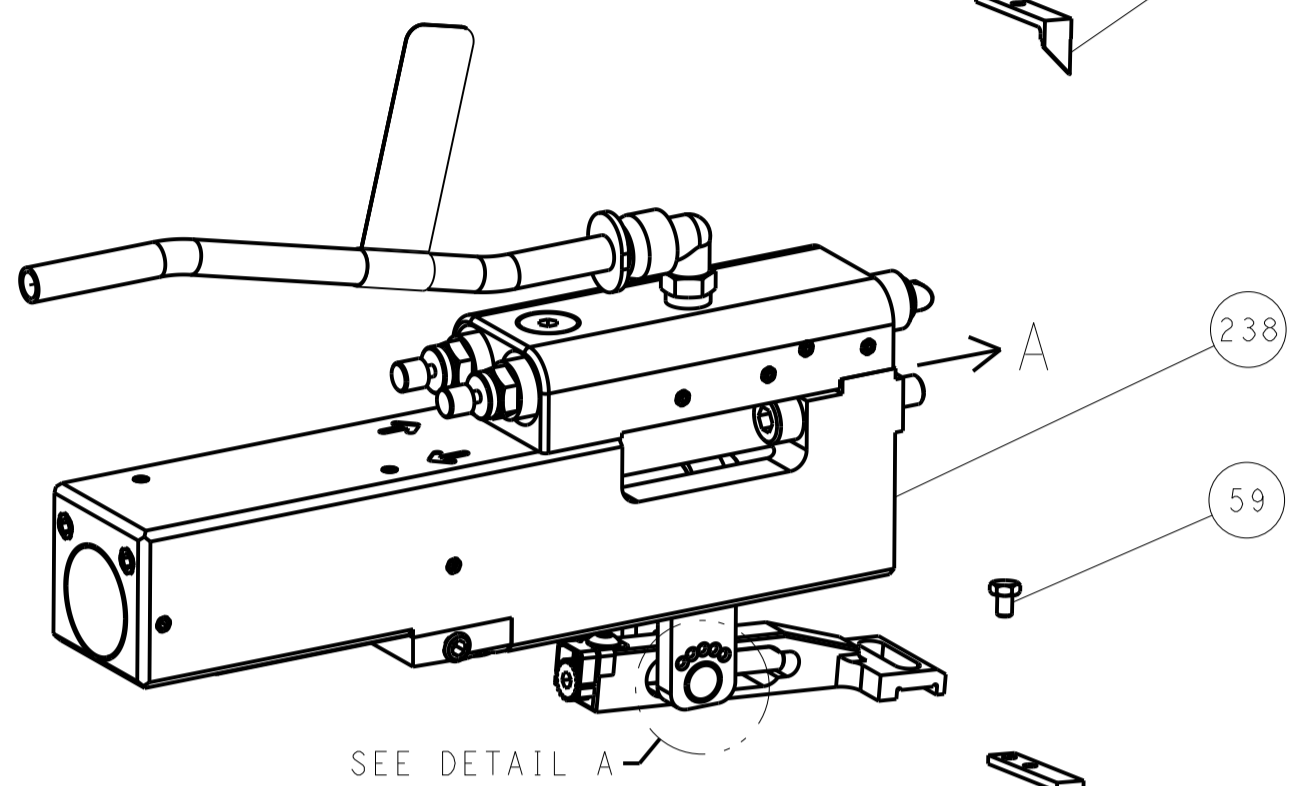

FEED SPRING SETTING POSITION (SHOWN FROM REAR SIDE)

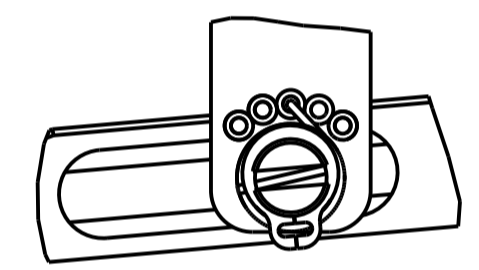

DETAIL A

DOUBLE ACTING PNEUMATIC WITH SENSORS

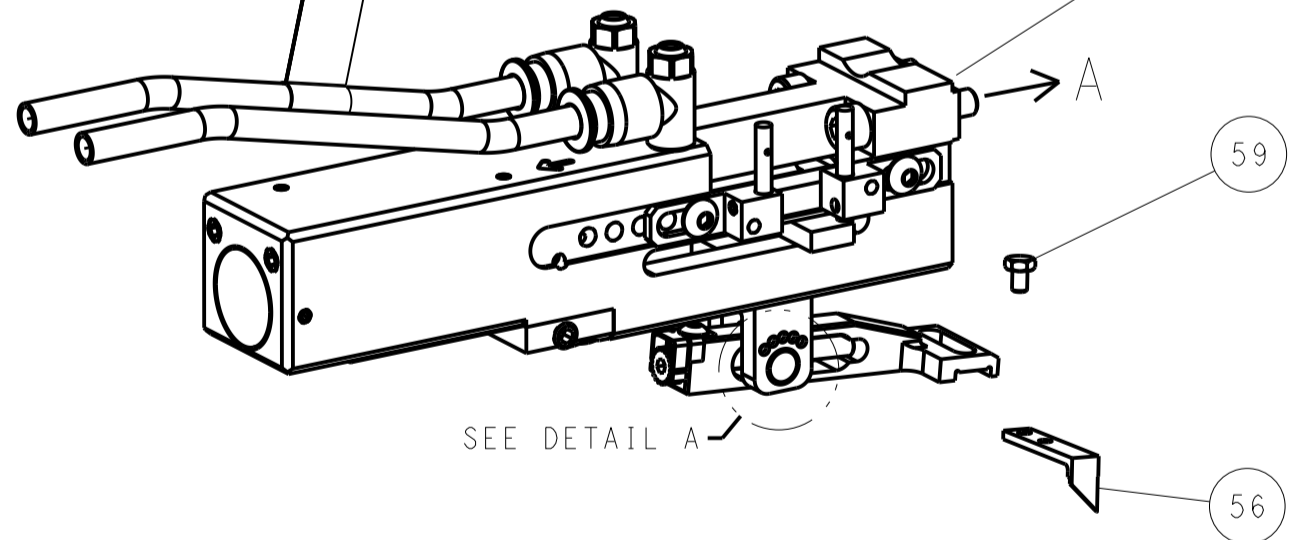

CAM POSITIONS

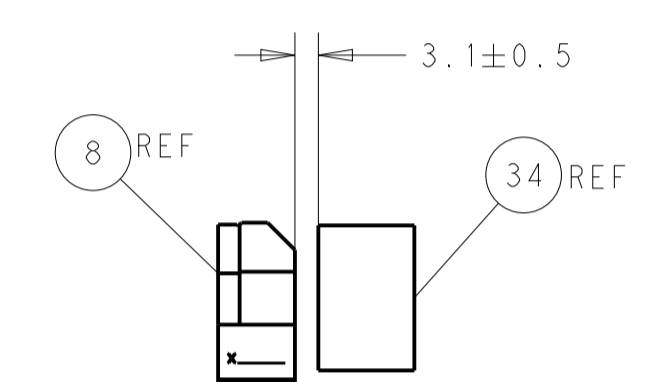
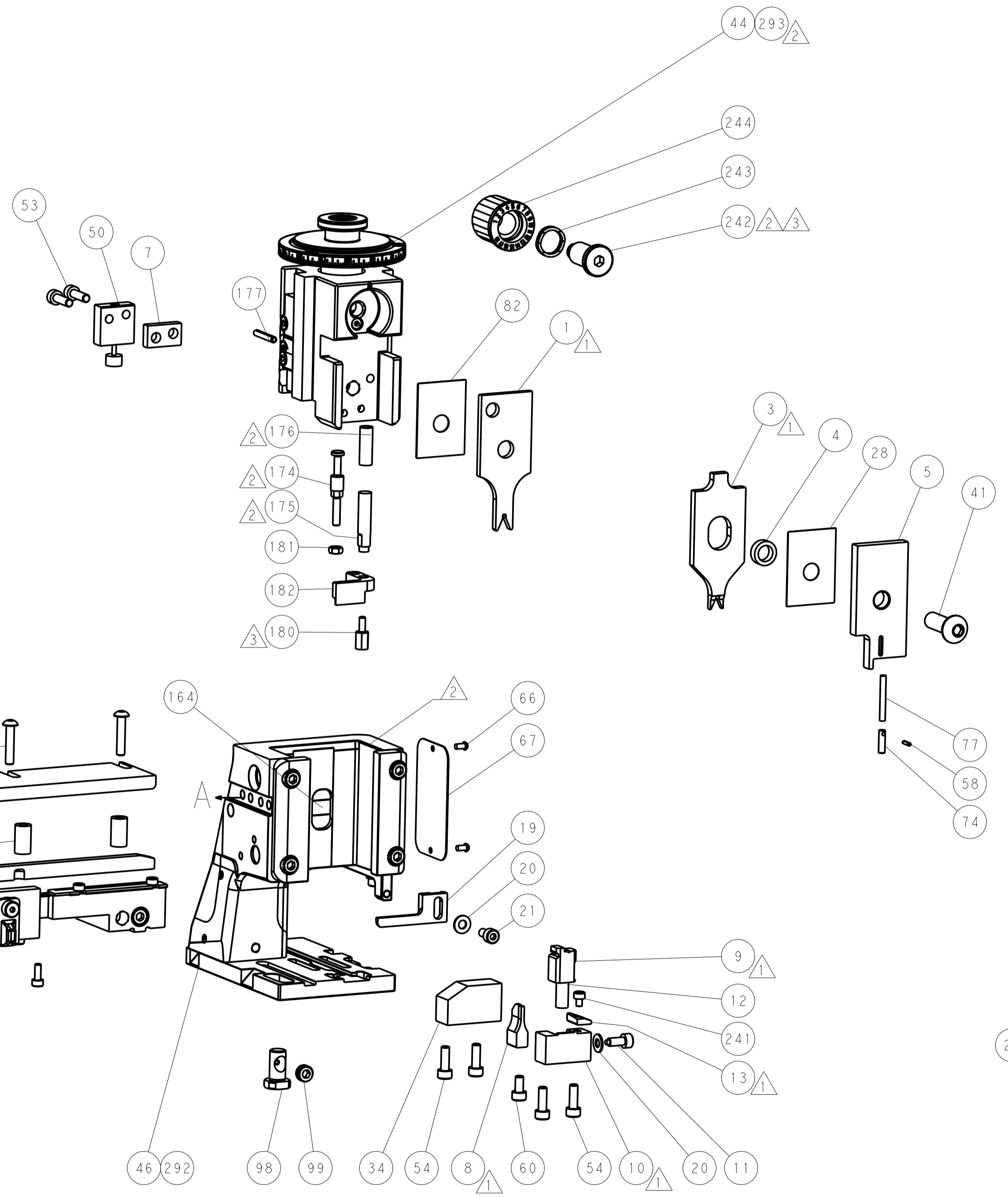
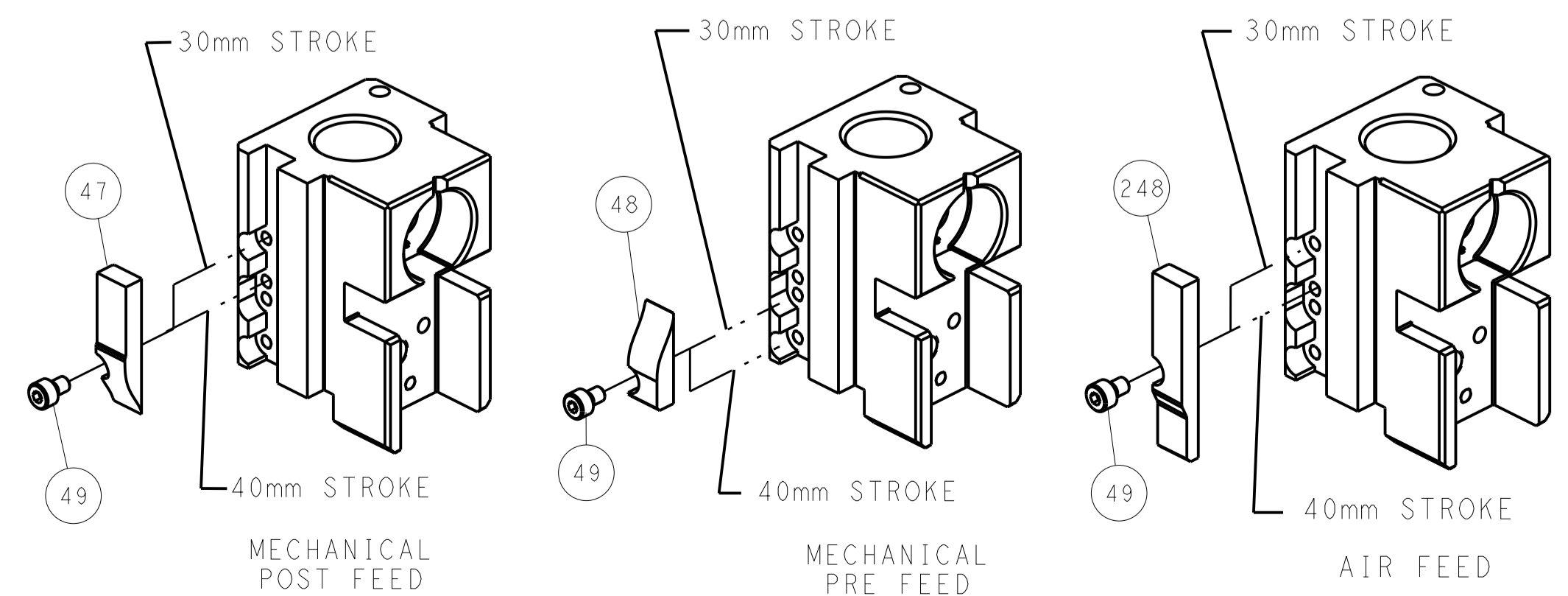

TERMINAL SUPPORT LOCATION

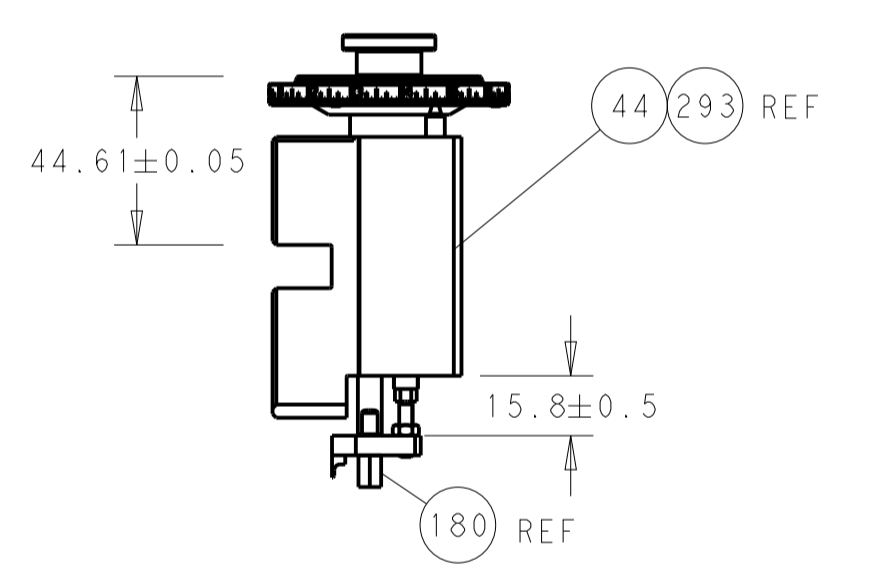

RAM AND HOLD-DOWN SET-UP

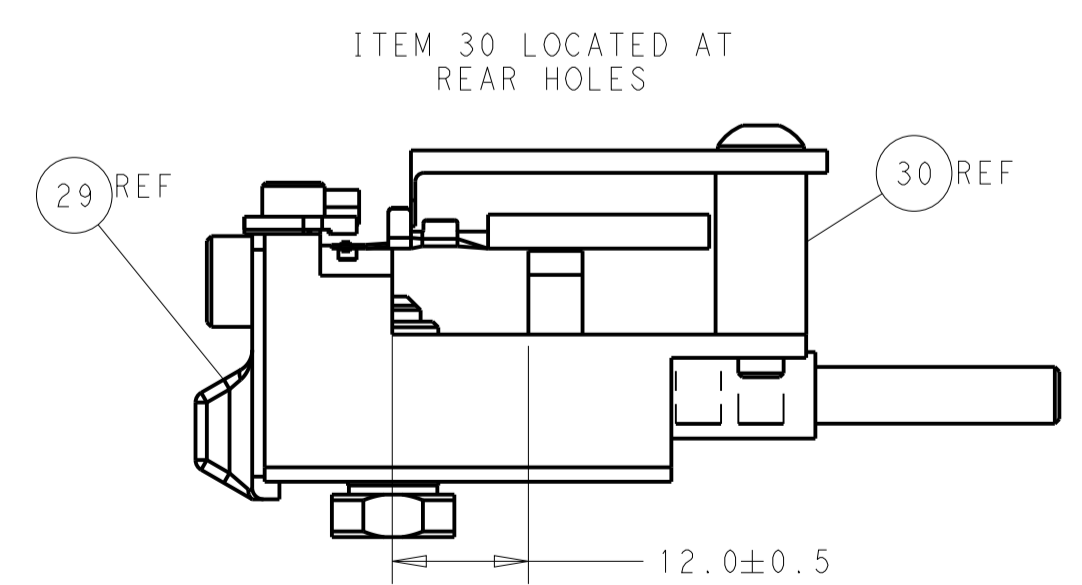

FEED TRACK POSITION GUIDE BY INSULATION BARREL

ATLANTIC VERSION
 Shown on sheets 1 of 4 & 2 of 4
 (Pacific version shown on sheets 3 of 4 & 4 of 4)

DIMENSIONS:		TOLERANCES UNLESS OTHERWISE SPECIFIED:		OWN: C. MOYER 24AUG2011		TE Connectivity	
mm	0 PLC ±	1 PLC ±	2 PLC ±	3 PLC ±	4 PLC ±	Harrisburg, PA 17105-3608	
MATERIAL:		FINISH:		APVD: T. ELBIN 24AUG2011		NAME: Ocean Side Feed Applicator	
				PRODUCT SPEC:		SIZE: CAGE CODE DRAWING NO. RESTRICTED TO	
				APPLICATION SPEC:		A1 00779 ©=2151300	
				WEIGHT:		Customer Accessible Production Drawing SCALE: 1:2 SHEET 2 OF 4 REV P	

PART NUMBER	REVISION	DESCRIPTION	FEED TYPE
2-2151300-1	P	FINE CRIMP HEIGHT ADJUST	MECHANICAL
2-2151300-2	P	FINE CRIMP HEIGHT ADJUST	PNEUMATIC
4-2151300-2	P	FINE CRIMP HEIGHT ADJUST	DOUBLE ACTING PNEUMATIC WITH SENSORS
7-2151300-7	N	CRIMP TOOLING KIT	-

PACIFIC VERSION TERMINATOR INTERFACE ADAPTER

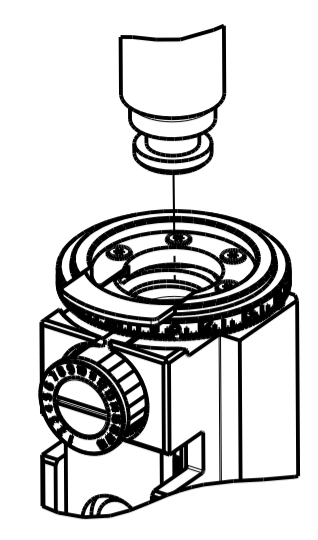

APPLICATOR DATA		
CRIMP	SIZE	TYPE
WIRE	1.40 mm [.055]	F
INSUL	1.83 mm [.072]	SPECIAL

APPLICATOR INSTRUCTIONS
408-35042

TERMINAL DATA: TE TERMINAL		TE CRIMP SPECIFICATION	
TERMINAL NAME: TAB CONTACT 1.2 MM			
WIRE STRIP LENGTH		INSULATION DIAMETER RANGE	
3.30-3.90 mm [.130-.154 IN]		Ø1.40-1.90 mm [.055-.075 IN]	
TERMINAL APPLICATION SPECIFICATION	114-18464		
TERMINALS APPLIED			
TE TERMINAL	TE TERMINAL	TE TERMINAL	TE TERMINAL
1418760-1	1418760-2	1418760-3	5-1418760-1
5-1418760-2	5-1418760-3		

WIRE SIZE	CRIMP HEIGHT mm [INCH]	CRIMP HEIGHT REFERENCE SETTING
0.75mm2	1.05 +/- 0.03 [.041 +/- .001]	6.7
0.5mm2 OR 20 AWG	0.93 +/- 0.03 [.037 +/- .001]	7.9

- RECOMMENDED SPARE PARTS
- REFER TO SUPPLIED INSTRUCTION SHEET FOR CLEANING, LUBRICATION AND STORAGE OF APPLICATOR.
- APPLY PART NUMBER 2-23419-6 LOCTITE TO THREADS OF ITEM 242.
- CRIMP HEIGHT REFERENCE SETTING WAS THE SETTING USED WHEN THE APPLICATOR WAS QUALIFIED AT THE FACTORY. ADJUSTMENT MAY BE NECESSARY WHEN RUNNING APPLICATOR IN THE FIELD.
- THIS APPLICATOR IS EQUIPPED WITH THE DOUBLE ACTING FEED WITH SENSORS AND IS APPLICATION SPECIFIC AND DOES NOT REQUIRE ITEMS 49 & 151.
- TERMINAL LUBRICANT IS RECOMMENDED.
- UNLESS SPECIFIED OTHERWISE TORQUE VALUES SHALL BE USED PER DOCUMENT, 101-35000.

***WARNING**
 ON INSTALLATION, SET WIRE DISC TO CRIMP HEIGHT REFERENCE SETTING FOR LARGEST WIRE SIZE. CRIMP HEIGHT REFERENCE SETTINGS GREATER THAN THE VALUE SHOWN MAY CAUSE DAMAGE TO THE CRIMP TOOLING, REFER TO THE INSTRUCTION SHEET FOR PROPER SETUP AND ADJUSTMENTS.

ENTRY LEVEL APPLICATOR		ITEM SUBSTITUTION LIST		
PART NUMBER	SAME AS	ITEM	ITEM DESCRIPTION	SUBSTITUTE PART NUMBER
8-2151300-1	2151300-1	1	WIRE CRIMPER	3-1803557-2
8-2151300-2	2151300-2	3	INSULATION CRIMPER	1803623-1
9-2151300-1	2-2151300-1	46	BASIC SUB -ASSEMBLY	1803940-9
9-2151300-2	2-2151300-2	141	BASIC SUB -ASSEMBLY	1-1803940-0
			LUBRICATOR	DELETE

PACIFIC VERSION
 Shown on sheets 3 of 4 & 4 of 4
 (Atlantic version shown on sheets 1 of 4 & 2 of 4)

LOC	DIST	REV	DATE	DESCRIPTION	DATE	BY	APPV
A	66	-	-	SEE SHEET 1	-	-	-

-	1	-	-	2844950-1	AIR FEED MODULE		290
-	2	2	2	2168083-1	SCR, SKT HD CAP, RoHS, M3 X 8.0		269
-	1	1	1	1-1633782-1	FENCE		267
-	1	1	1	2119082-5	CAM, SNAIL, INSULATION ADJUSTMENT		244
-	1	1	1	2079764-1	WASHER, WAVE SPRING, CREST-TO-CREST		243
-	1	1	1	2119083-1	RETAINER, INSULATION DIAL		242
-	1	1	1	7-18023-7	SCR, SKT HD CAP M3 X 4.0		241
-	-	-	1	2119580-1	MECHANICAL FEED ASSEMBLY		239
-	-	1	-	2844940-1	AIR FEED MODULE		238
-	REF	REF	REF	994970-2	COUNTER, MAGNETIC		164
-	-	1	-	2119641-2	FEED CAM, AIR FEED		151
-	1	1	1	2168083-8	SCR, SKT HD CAP, RoHS, M4 X 16		144
-	4	4	4	2168083-9	SCR, SKT HD CAP, RoHS, M4 X 20		143
-	-	-	1	2119653-2	FEED CAM, POST FEED		142
-	1	1	1	1-1803583-0	APPLICATOR BASIC ASSEMBLY, SF		141
-	1	1	1	1803516-1	RAM ASSEMBLY, SF PACIFIC		140
-	1	1	1	2119955-1	ASSY, LUBRICATOR, SIDE FEED		113
-	1	1	1	2844908-1	SCREW, LOCKING		99
-	1	1	1	2844907-1	POST, LOCKING		98
-	1	1	1	455888-5	SPACER, CRIMPER		82
-	1	1	1	5-547505-2	SPRING, COMPRESSION		77
-	1	1	1	854769-5	HOLDER, INS		74
-	1	1	1	1803607-3	DOCUMENTATION PACKAGE		71
-	1	1	1	2119740-1	TAG, IDENTIFICATION		67
-	2	2	2	2168078-1	SCREW, DRIVE, RH, RoHS, 2 x .188		66
-	1	1	1	5-18022-5	SCR, HEX HD CAP, M4 X 6.0		59
-	1	1	1	21028-2	PIN, SLOTTED SPRING .062 X .250		58
-	1	1	1	1338685-1	PAWL, FEED		56
-	2	2	2	2-2168083-5	SCR, SKT HD CAP, RoHS, M4 X 14		53
-	1	1	1	1803382-6	HOLD DOWN, SPRING LOADED		50
-	-	1	2	18023-9	SCR, SKT HD CAP M4 X 6.0		49
-	-	-	1	2119652-1	FEED CAM, PRE FEED		48
-	1	1	1	1803602-1	SCR, BHSC, RoHS (M8 X 25)		41
-	1	1	1	2-1752356-0	SUPPORT, TERMINAL		34
-	2	2	2	2079383-5	SCR, BHSC, RoHS (M4 X 20)		33
-	2	2	2	2-2844962-6	SPACER, CYLINDRICAL, STRIP GUIDE		30
-	1	1	1	2844992-2	ASSEMBLY, STRIP GUIDE		29
-	1	1	1	455888-3	SPACER, CRIMPER		28
-	1	1	1	1320928-6	STRIP GUIDE		24
-	1	1	1	2168083-2	SCR, SKT HD CAP, RoHS, M4 X 8.0		21
-	2	2	2	1-18028-2	WASHER, FLAT, REG M4		20
-	1	1	1	2119533-1	STRIPPER, SIDE FEED		19
-	1	1	1	2119806-1	INSERT, SHEAR		13
-	1	1	1	3-22280-3	SPRING, COMPRESSION		12
-	1	1	1	1-356885-4	STOP, SHEAR		11
-	1	1	1	2119805-1	SHEAR HOLDER, FRONT		10
-	1	1	1	1633861-4	SHEAR, FLOATING		9
1	1	1	1	1-1333231-3	ANVIL, COMBINATION, SPECIAL		8
-	1	1	1	5-240641-0	SPACER		7
-	1	1	1	1-2119780-1	DEPRESSOR, SHEAR		5
-	1	1	1	4-238011-2	BLOCK, CRIMPER SPACER		4
1	1	1	1	1633989-1	CRIMPER, INSULATION, SPECIAL		3
1	1	1	1	3-1633730-2	CRIMPER, WIRE		1

DIMENSIONS: mm		TOLERANCES UNLESS OTHERWISE SPECIFIED:		DWN: MOYER 24AUG2011		CHK: T. ELBIN 24AUG2011		APVD: T. ELBIN 24AUG2011		NAME: Ocean Side Feed Applicator	
0 PLC ±		1 PLC ±		2 PLC ±		3 PLC ±		4 PLC ±		SIZE: 00779	
ANGLES		FINISH		WEIGHT		SCALE: 1:2		SHEET: 3 OF 4		REV: P	

Customer Accessible Production Drawing

LOC		DIST		REVISIONS			
A	66	P	LTM	DESCRIPTION	DATE	DWN	APVD
		-	-	SEE SHEET 1	-	-	-

FEED TYPE MECHANICAL

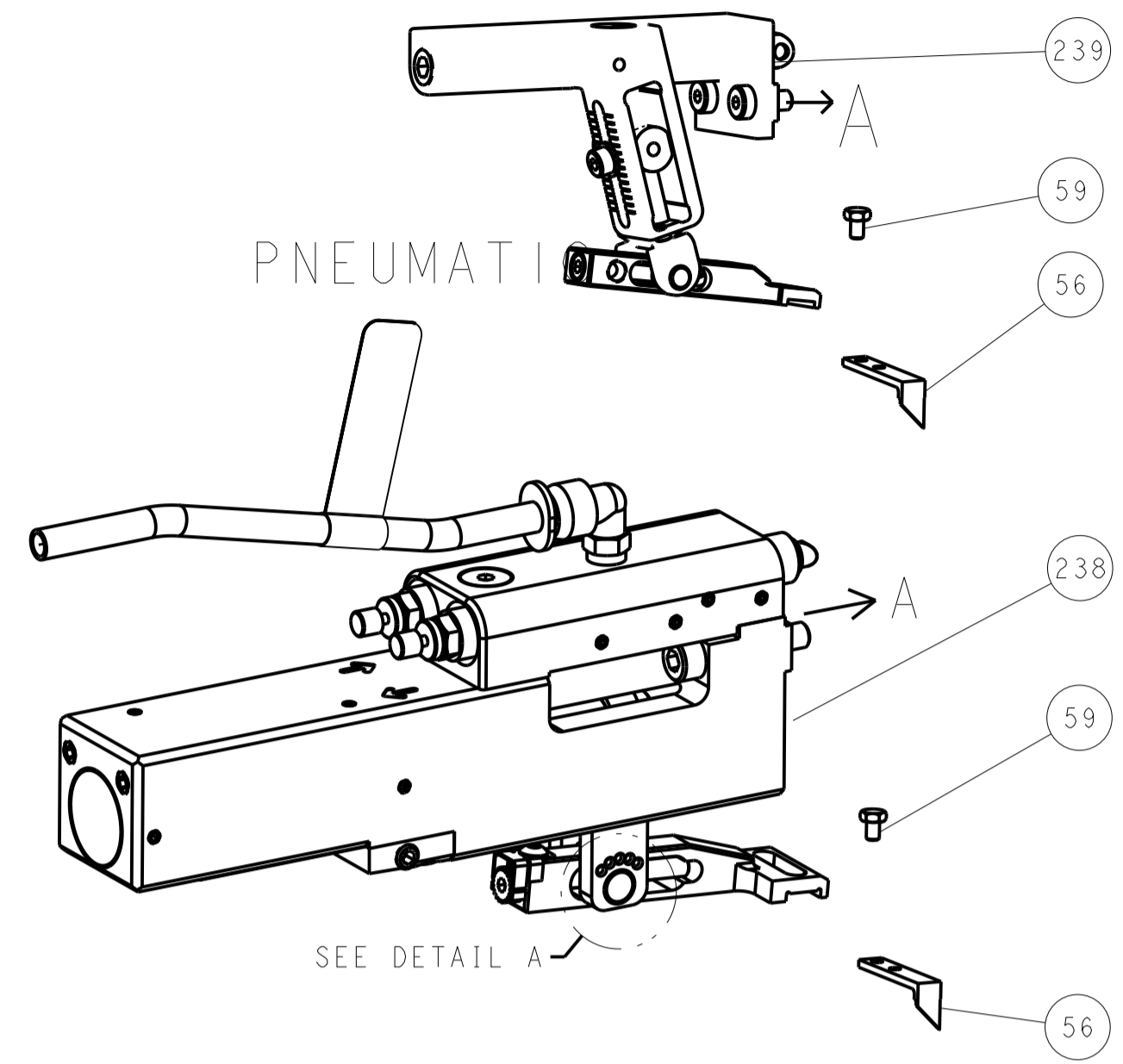

PNEUMATIC

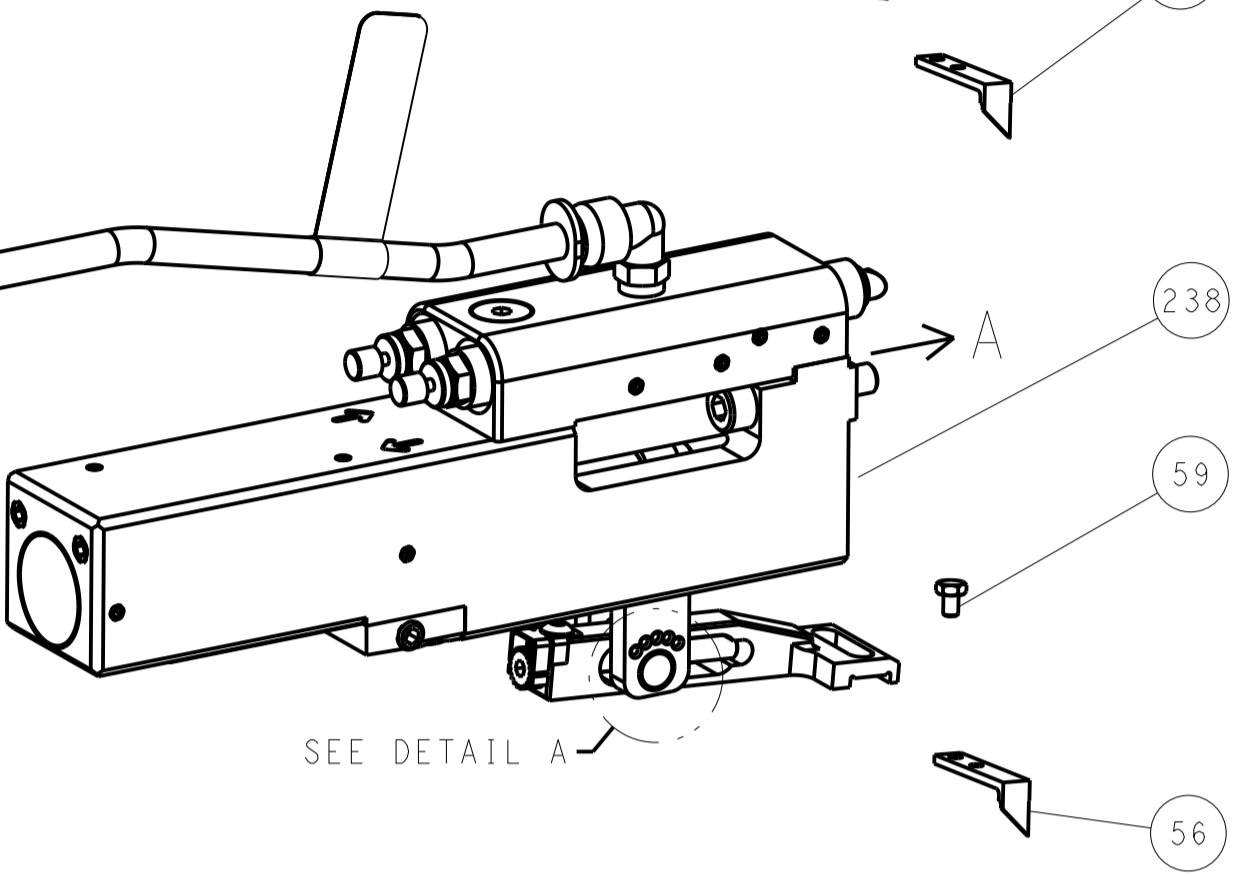

FEED SPRING SETTING POSITION (SHOWN FROM REAR SIDE)

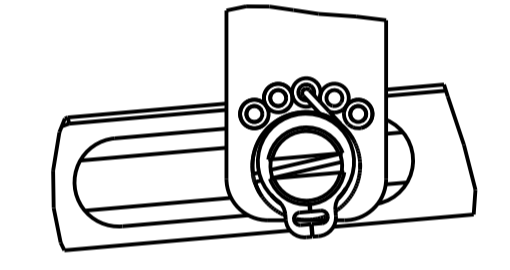

DETAIL A

DOUBLE ACTING PNEUMATIC WITH SENSORS

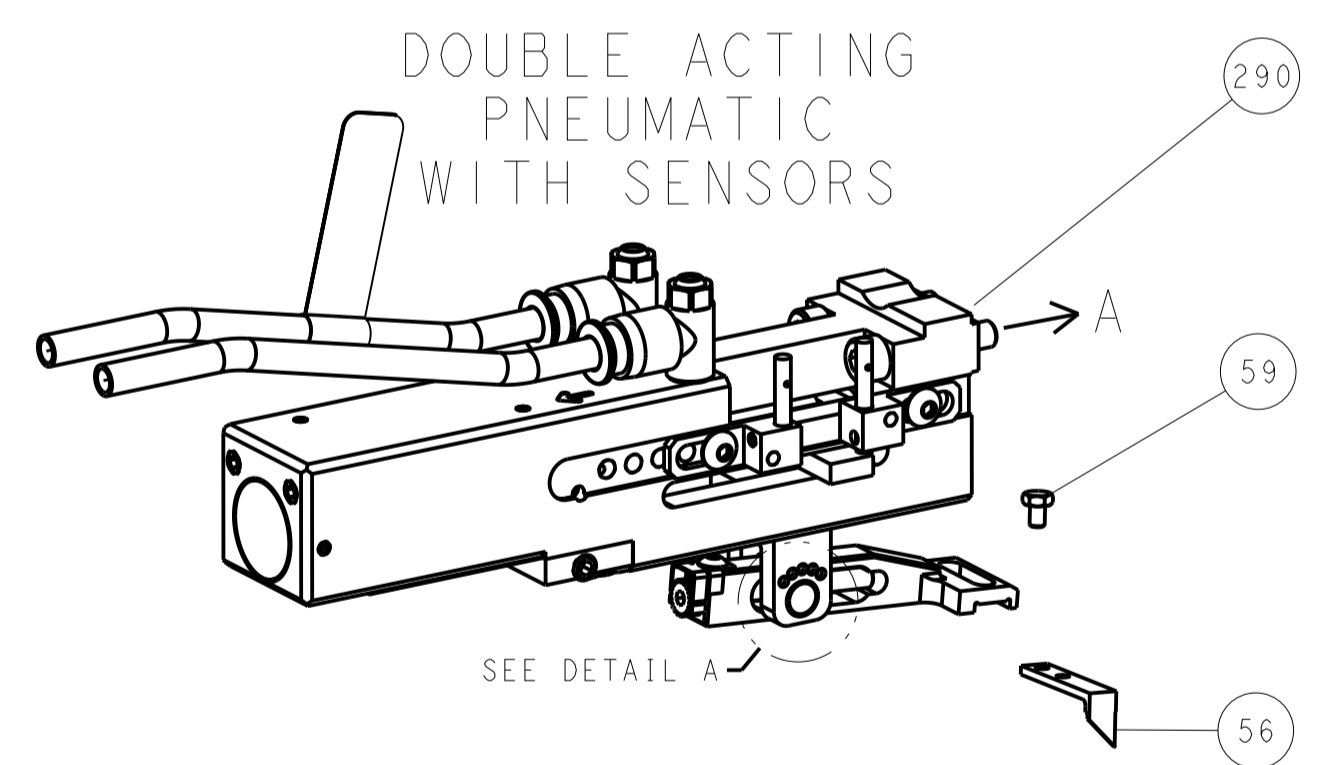

CAM POSITIONS

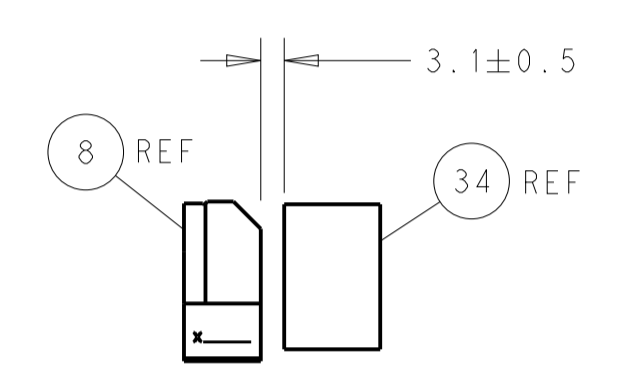
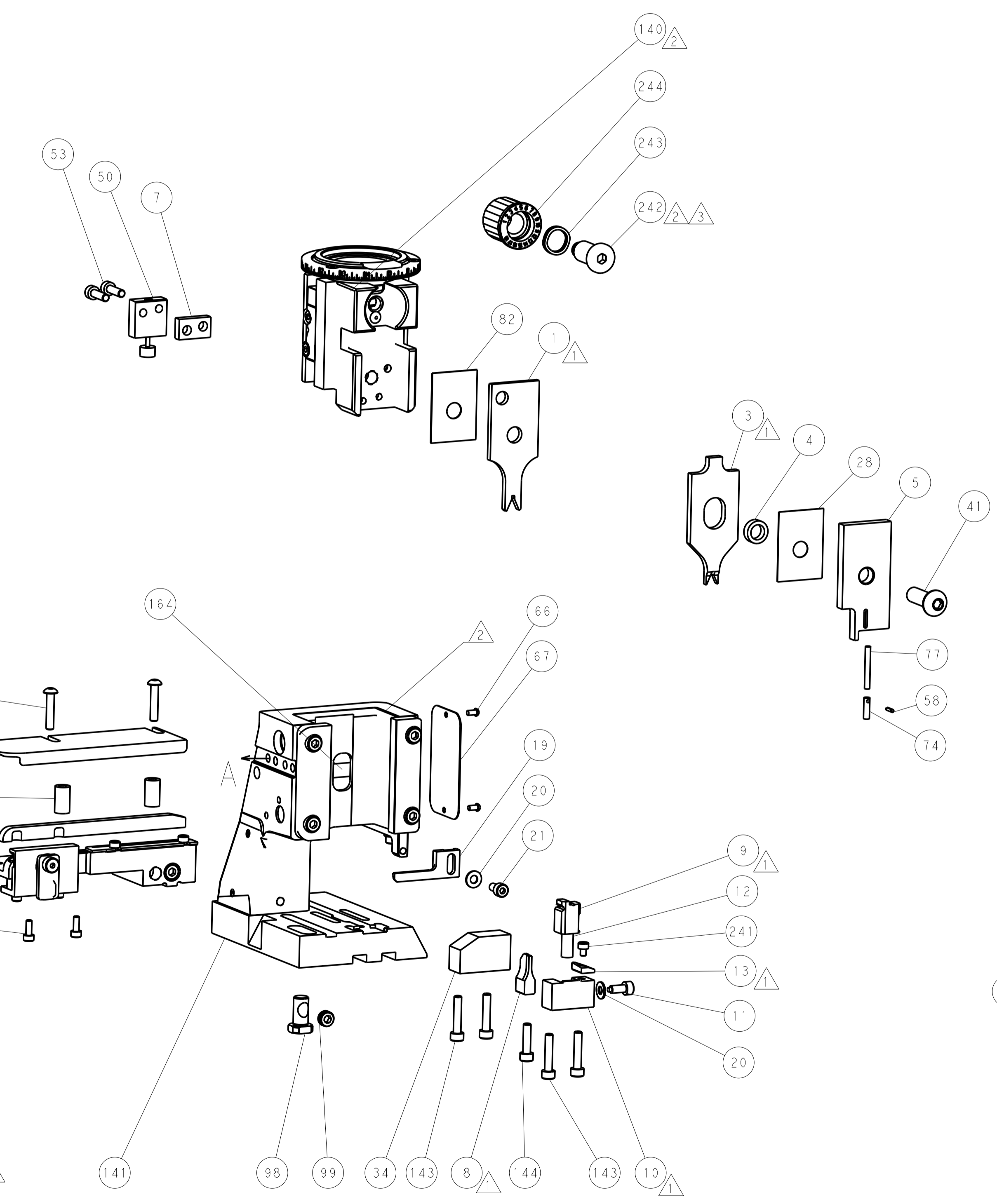
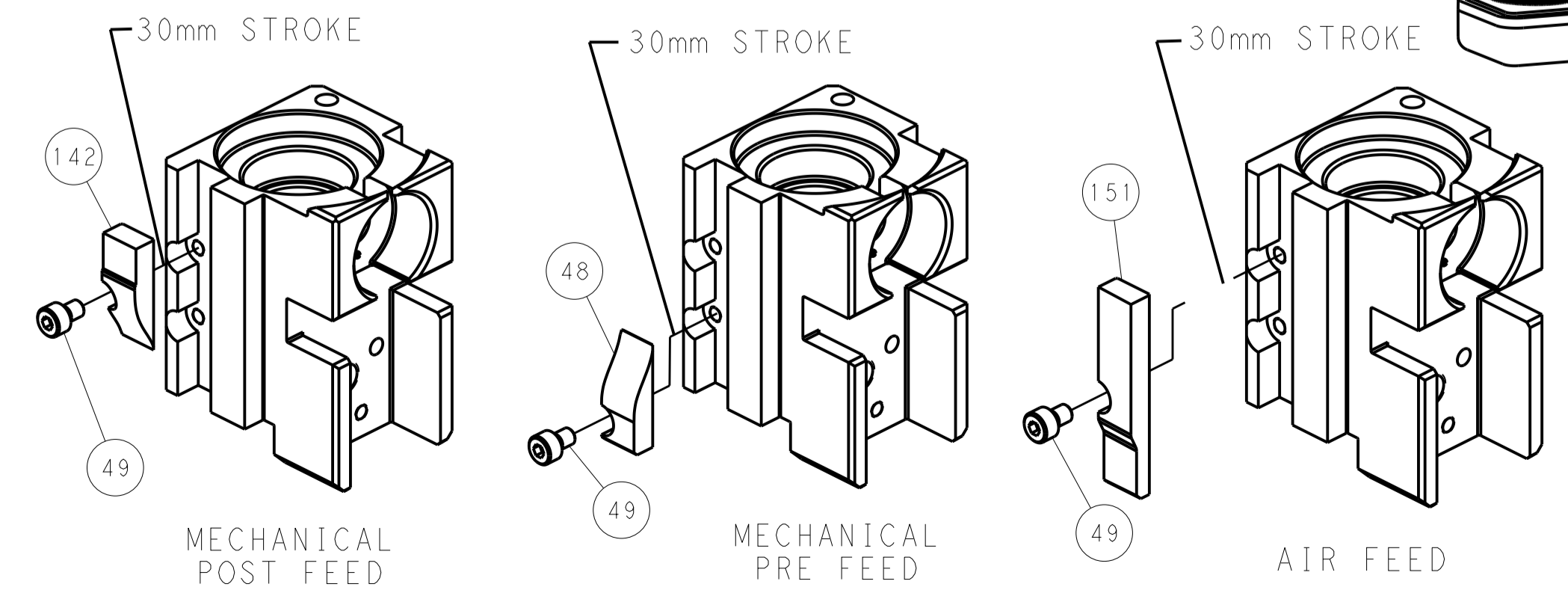

TERMINAL SUPPORT LOCATION

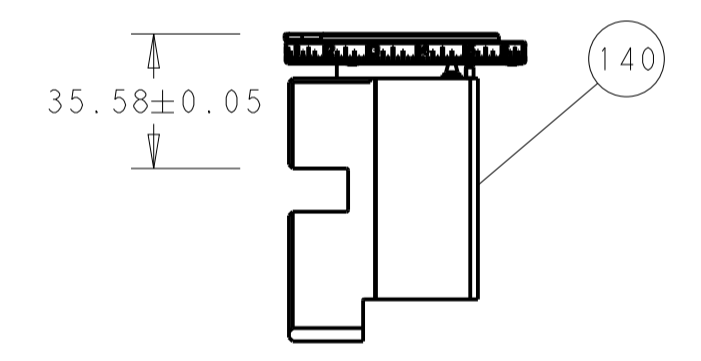

RAM SET-UP

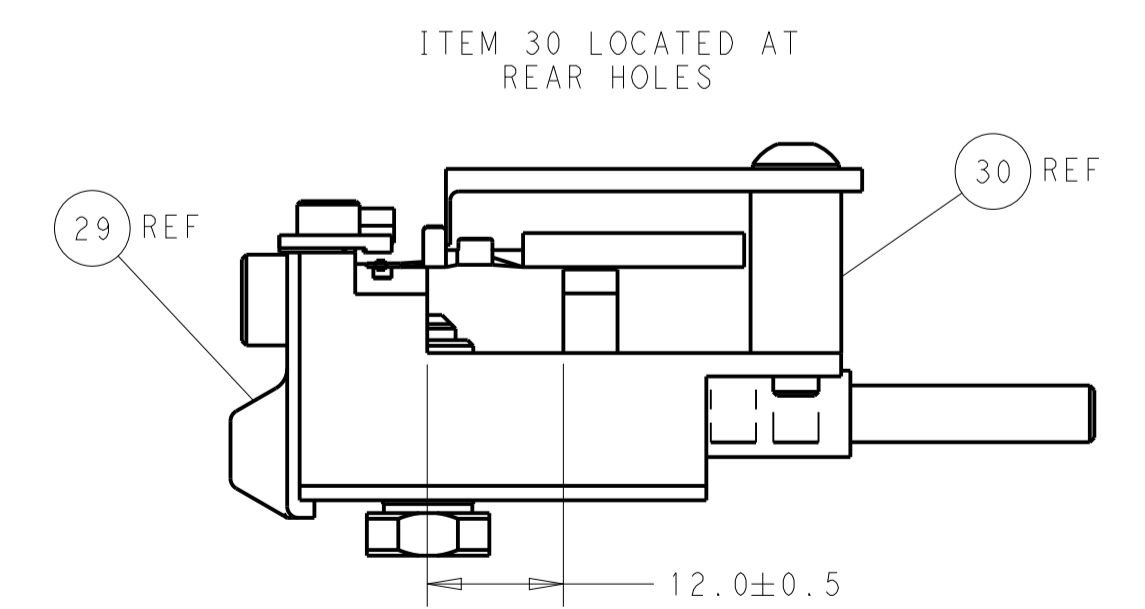

FEED TRACK POSITION
GUIDE BY INSULATION BARREL

PACIFIC VERSION
 Shown on sheets 3 of 4 & 4 of 4
 (Atlantic version shown on sheets 1 of 4 & 2 of 4)

DIMENSIONS:		TOLERANCES UNLESS OTHERWISE SPECIFIED:		DWN C. MOYER 24AUG2011		TE Connectivity	
mm	0 PLC ±	1 PLC ±	2 PLC ±	3 PLC ±	4 PLC ±	Harrisburg, PA 17105-3608	
MATERIAL:		FINISH:		APVD T. ELBIN 24AUG2011		NAME Ocean Side Feed Applicator	
				PRODUCT SPEC		SIZE CAGE CODE DRAWING NO	
				APPLICATION SPEC		RESTRICTED TO	
				WEIGHT		A 00779 ©=2151300	
				Customer Accessible Production Drawing		SCALE 1:2 SHEET 4 OF 4 REV P	

Mouser Electronics

Authorized Distributor

Click to View Pricing, Inventory, Delivery & Lifecycle Information:

[TE Connectivity:](#)

[7-2151300-7](#)