

PART NUMBER	REVISION	DESCRIPTION	FEED TYPE
2151177-2	K	FINE CRIMP HEIGHT ADJUST	PNEUMATIC
5-2151177-2	K	SEAL STRIPPER CRIMPER TERMINATING UNIT	PNEUMATIC
7-2151177-2	K	PNEUMATIC AND CRIMP TOOLING KIT	PNEUMATIC
7-2151177-7	F	CRIMP TOOLING KIT	-

ATLANTIC VERSION TERMINATOR INTERFACE ADAPTER

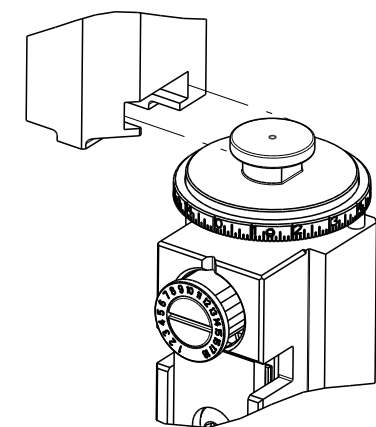

APPLICATOR DATA		
CRIMP	SIZE	TYPE
WIRE	2.79 mm [.110]	F
INSUL	6.60 mm [.260]	O

APPLICATOR INSTRUCTIONS 408-35042

TERMINAL DATA: TE TERMINAL		TE CRIMP SPECIFICATION	
TERMINAL NAME: STANDARD POWER TIMER TERMINAL			
WIRE STRIP LENGTH		INSULATION DIAMETER RANGE	
4.90-5.50 mm [.193-.217 IN]		∅2.20-3.70 mm [.087-.146 IN]	
TERMINAL APPLICATION SPECIFICATION	(A)1114-18037		
	(B)1114-18388		

TERMINALS APPLIED				SEAL INSULATION DIAMETER RANGE
TE TERMINAL	TE TERMINAL	TE SEAL	TE SEAL	
(A) 969042-1			963244-1	∅ 2.2-3.0mm
(B) 1241414-1			963245-1	∅ 3.4-3.7mm
(B) 1241414-3			1394511-1	∅ 2.0-2.7mm

WIRE SIZE	CRIMP HEIGHT mm [INCH]	CRIMP HEIGHT REFERENCE SETTING
2.50mm2	1.89+/-0.05 [.074+/- .002]	6.2
1.50mm2	1.64+/-0.05 [.065+/- .002]	9.7

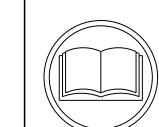

- 1. RECOMMENDED SPARE PARTS
- 2. REFER TO SUPPLIED INSTRUCTION SHEET FOR CLEANING, LUBRICATION AND STORAGE OF APPLICATOR.
- 3. APPLY PART NUMBER 1-23419-5 LOCTITE TO THREADS OF ITEM 180. APPLY PART NUMBER 2-23419-6 LOCTITE TO THREADS OF ITEM 242.
- 4. CRIMP HEIGHT REFERENCE SETTING WAS THE SETTING USED WHEN THE APPLICATOR WAS QUALIFIED AT THE FACTORY. ADJUSTMENT MAY BE NECESSARY WHEN RUNNING APPLICATOR IN THE FIELD.
- 5. TERMINAL PITCH NOT COMPATIBLE WITH MECHANICAL FEED.
- 6. APPLY TORO-SEAL IN ALLEN SOCKET TO FILL HOLE AFTER FLAT HD HAS BEEN ADJUSTED TO CORRECT HEIGHT AT QUALIFICATION. APPLY #1-23419-5 LOC-TITE TO THREADS.
- 7. UNLESS SPECIFIED OTHERWISE TORQUE VALUES SHALL BE USED PER DOCUMENT, 101-35000.
- 8. TERMINAL LUBRICANT IS RECOMMENDED.

**\*WARNING**  
ON INSTALLATION, SET WIRE DISC TO CRIMP HEIGHT REFERENCE SETTING FOR LARGEST WIRE SIZE. CRIMP HEIGHT REFERENCE SETTINGS GREATER THAN THE VALUE SHOWN MAY CAUSE DAMAGE TO THE CRIMP TOOLING, REFER TO THE INSTRUCTION SHEET FOR PROPER SETUP AND ADJUSTMENTS.

LOC	DIST	REVISIONS					
		P	LTN	DESCRIPTION	DATE	OWN	APVD
A	66	G		ECR-18-009200	13JUN2018	JAH	JDG
		H		ECR-18-015608	02OCT2018	JAH	CT
		J		ECR-19-005438	04APR2019	LG	TE
		K		ECR-21-006026	03JUN2021	LG	RK

-	-	1	-	1803515-3	RAM ASSEMBLY, SF ATLANTIC	293
-	-	1	-	2-1803583-1	APPLICATOR BASIC ASSEMBLY, SF	292
-	1	1	1	2119641-1	FEED CAM, AIR FEED	248
-	1	1	1	2119082-2	CAM, SNAIL, INSULATION ADJUSTMENT	244
-	1	1	1	2079764-1	WASHER, WAVE SPRING, CREST-TO-CREST	243
3	-	1	1	2119083-1	RETAINER, INSULATION DIAL	242
-	1	1	1	7-18023-7	SCR, SKT HD CAP M3 X 4.0	241
-	1	1	1	2844940-1	AIR FEED MODULE	238
-	-	1	-	4-1722335-3	STRIPPER, SIDE FEED	182
-	-	1	-	1-5018030-0	NUT, HEX, REG, RoHS, M3.5	181
3	-	1	-	1-1752354-2	STANDOFF,HOLD-DOWN	180
-	-	1	-	993111-1	PIN, SLOTTED SPRING 3.0 X 20.0	177
-	-	1	-	5-22280-0	SPRING, COMPRESSION	176
-	-	1	-	1752353-3	GUIDE PIN,HOLDDOWN	175
-	-	1	-	1901680-2	GUIDE PIN,HOLDDOWN	174
-	REF	REF	REF	994970-2	COUNTER, MAGNETIC	164
8	-	1	1	2119955-1	ASSY, LUBRICATOR, SIDE FEED	113
-	1	1	1	2844908-1	SCREW, LOCKING	99
-	1	1	1	2844907-1	POST, LOCKING	98
-	1	1	1	455888-7	SPACER, CRIMPER	82
-	1	1	1	1803607-3	DOCUMENTATION PACKAGE	71
-	1	1	1	2119791-5	DEPRESSOR, WIRE	70
-	1	1	1	2119943-1	WASHER, SPACER	69
-	1	1	1	2119740-1	TAG, IDENTIFICATION	67
-	2	2	2	2168078-1	SCREW, DRIVE, RH, RoHS, 2 x .188	66
-	1	1	1	2168083-2	SCR, SKT HD CAP, RoHS, M4 X 8.0	60
-	1	1	1	5-18022-5	SCR, HEX HD CAP, M4 X 6.0	59
6	-	1	1	985575-3	SCR, FLT SKT HD CAP M3 X 10.0	57
-	1	1	1	1338685-1	PAWL, FEED	56
-	4	4	4	2168083-3	SCR, SKT HD CAP, RoHS, M4 X 12.0	54
-	2	2	2	1-2168083-0	SCR, SKT HD CAP, RoHS, M4 X 10	53
-	1	1	1	1803382-2	HOLD DOWN, SPRING LOADED	50
-	1	1	1	18023-9	SCR, SKT HD CAP M4 X 6.0	49
-	1	-	1	1803583-9	APPLICATOR BASIC ASSEMBLY, SF	46
-	1	-	1	1803515-1	RAM ASSEMBLY, SF ATLANTIC	44
-	1	1	1	1803602-1	SCR, BHSC, RoHS (M8 X 25)	41
-	1	1	1	1-1752356-1	SUPPORT, TERMINAL	34
-	2	2	2	2079383-5	SCR, BHSC, RoHS (M4 X 20)	33
-	2	2	2	3-2844962-2	SPACER, CYLINDRICAL, STRIP GUIDE	30
-	1	1	1	2844992-2	ASSEMBLY, STRIP GUIDE	29
-	1	1	1	455888-6	SPACER, CRIMPER	28
-	1	1	1	1320928-6	STRIP GUIDE	24
-	1	-	1	2168083-2	SCR, SKT HD CAP, RoHS, M4 X 8.0	21
-	2	1	2	1-18028-2	WASHER, FLAT, REG M4	20
-	1	-	1	2119533-1	STRIPPER, SIDE FEED	19
1	-	1	1	2119806-1	INSERT, SHEAR	13
-	1	1	1	3-22280-3	SPRING, COMPRESSION	12
-	1	1	1	1-356885-4	STOP, SHEAR	11
1	-	1	1	2119805-1	SHEAR HOLDER, FRONT	10
1	-	1	1	318707-1	FLOATING SHEAR, FRONT	9
1	1	2	1	1333229-2	ANVIL, COMBINATION	8
-	1	1	1	2-240641-8	SPACER	7
-	1	1	1	2119781-5	DEPRESSOR, SHEAR	5
-	1	1	1	238011-8	BLOCK, CRIMPER SPACER	4
1	1	2	1	1803464-8	CRIMPER, INSULATION O	3
-	1	1	1	1-455888-1	SPACER, CRIMPER	2
1	1	2	1	456408-3	CRIMPER, WIRE PREMIUM	1

ATLANTIC VERSION  
Shown on sheets 1 of 4 & 2 of 4  
(Pacific version shown on sheets 3 of 4 & 4 of 4)

DIMENSIONS:		TOLERANCES UNLESS OTHERWISE SPECIFIED:		MATERIAL:	
mm	0 PLC ±	1 PLC ±	2 PLC ±	3 PLC ±	4 PLC ±
	ANGLES	FINISH			

OWN	X. ZHAO	02JUN2011	
CHK	S. XI	02JUN2011	
APVD	J. CRUZ	02JUN2011	
NAME	Ocean Side Feed Applicator		
SIZE	CAGE CODE	DRAWING NO	RESTRICTED TO
A1	00779	2151177	
Customer Accessible Production Drawing		SCALE	1:2
SHEET		1	OF 4
REV		K	

LOC	DIST	REVISIONS					
A	66	P	LTN	DESCRIPTION	DATE	OWN	APVD
		-		SEE SHEET 1	-	-	-

# FEED TYPE

## PNEUMATIC

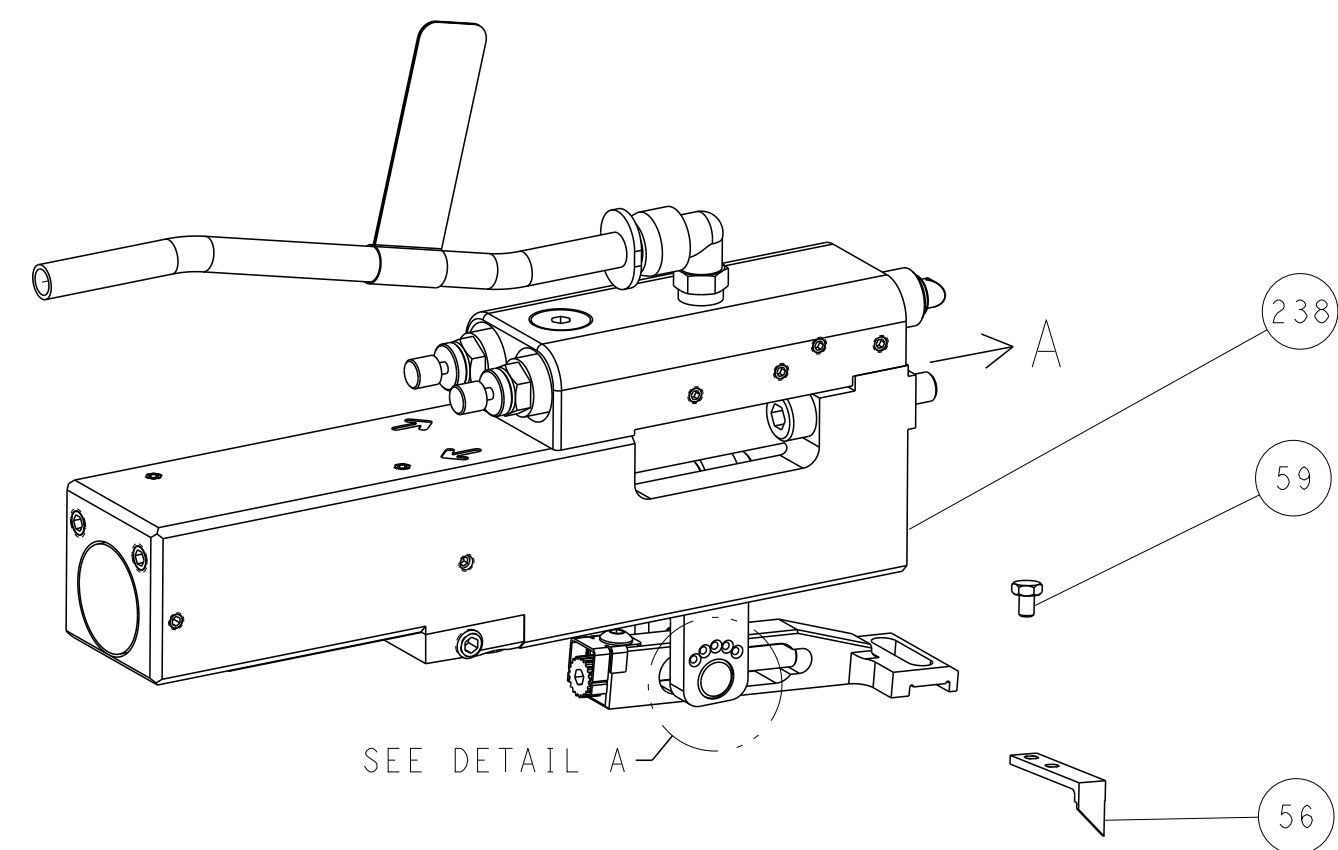

## FEED SPRING SETTING POSITION (SHOWN FROM REAR SIDE)

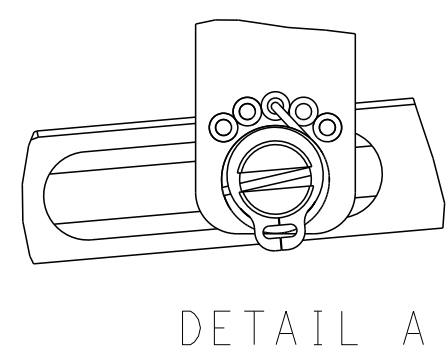

## CAM POSITION

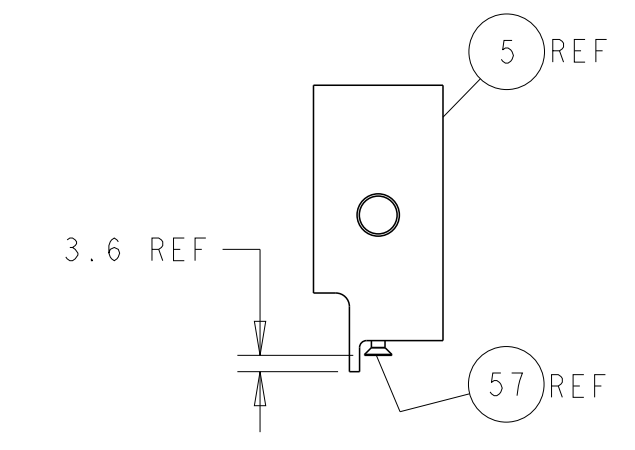
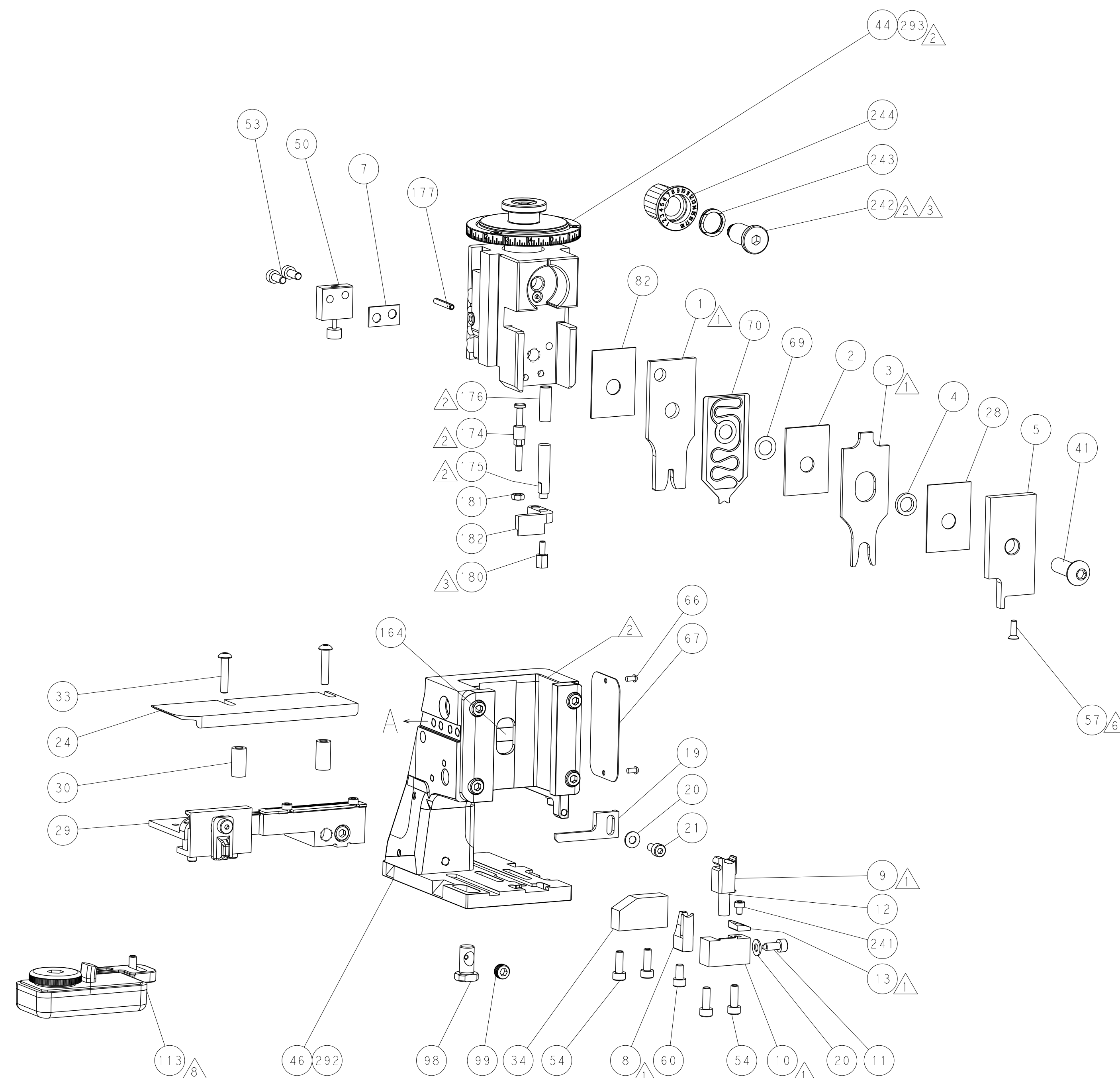
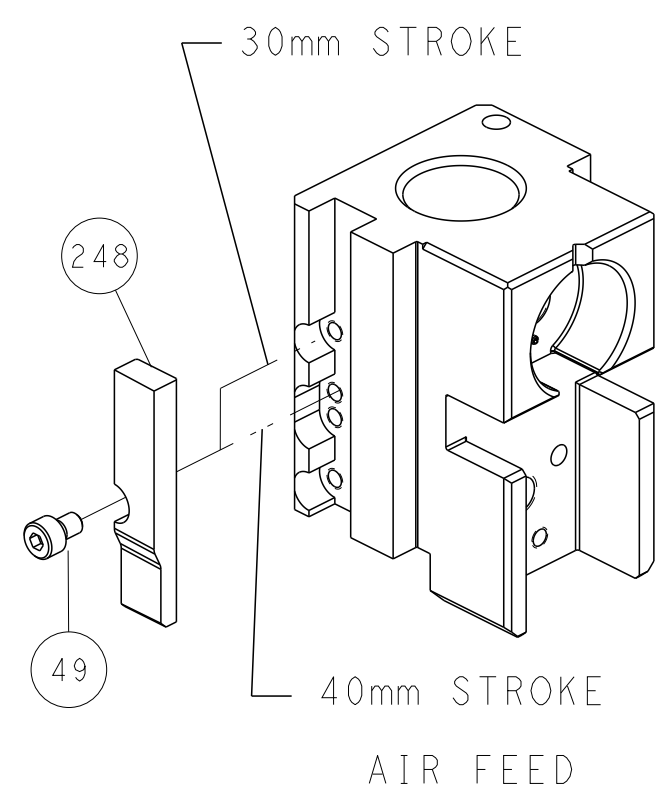

SHEAR DEPRESSOR DETAIL

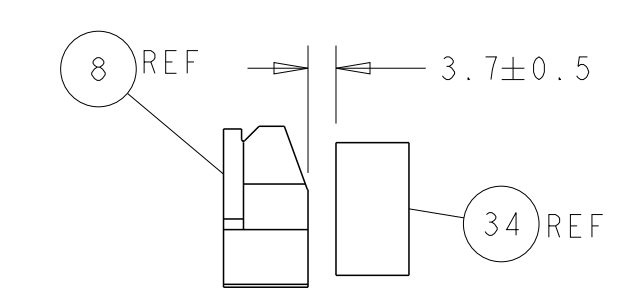

TERMINAL SUPPORT LOCATION

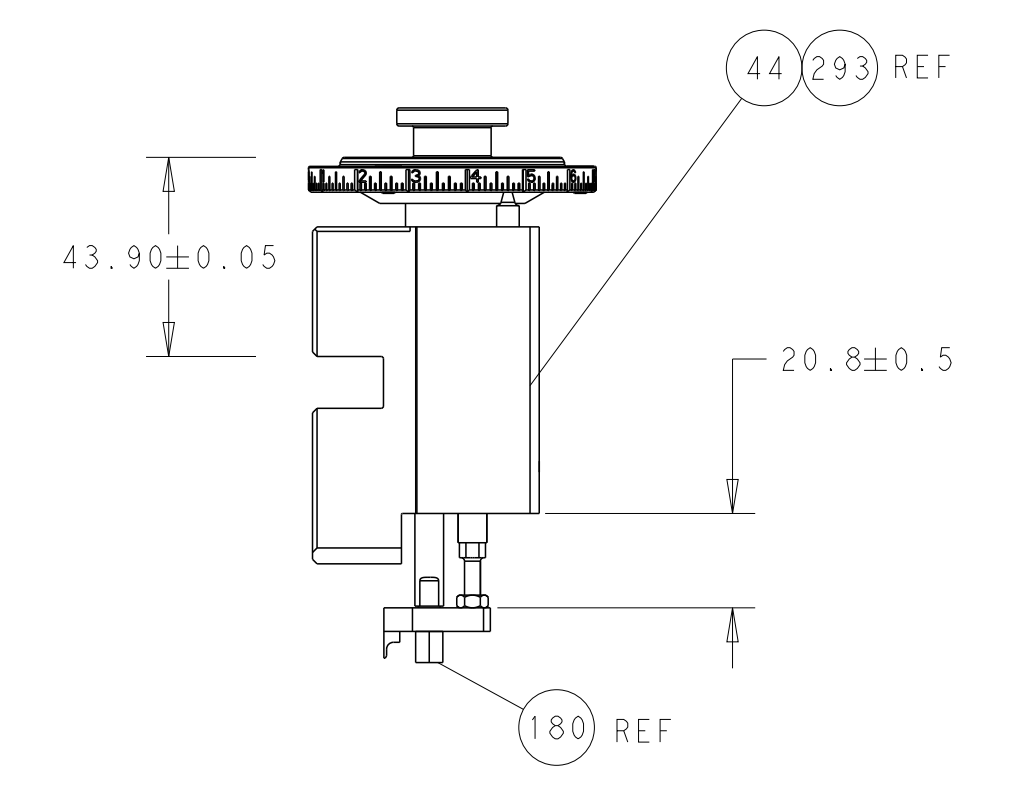

RAM AND HOLDDOWN SET-UP

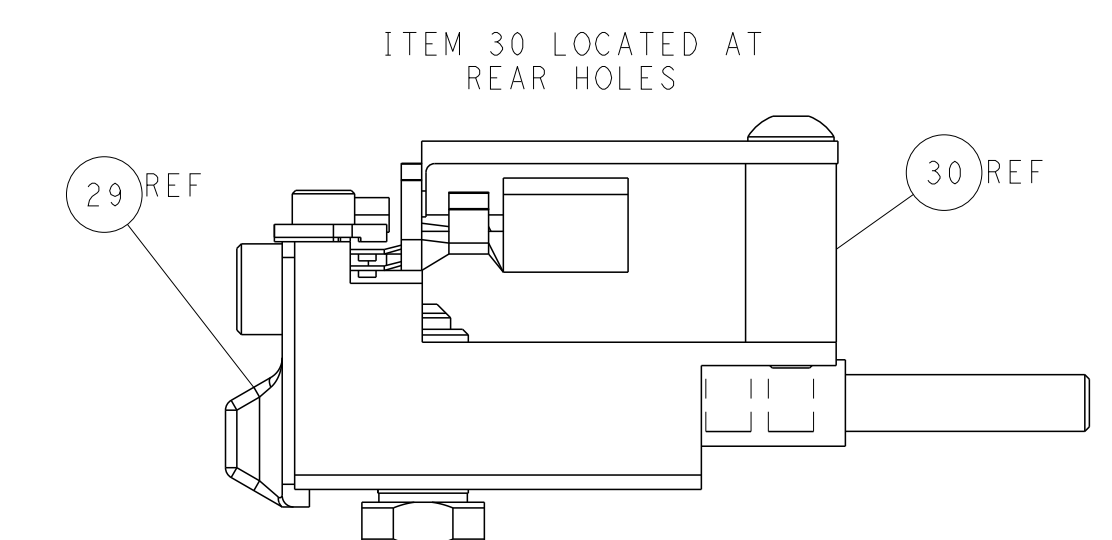

FEED TRACK POSITION GUIDE BY INSULATION BARREL

**ATLANTIC VERSION**  
 Shown on sheets 1 of 4 & 2 of 4  
 (Pacific version shown on sheets 3 of 4 & 4 of 4)

DIMENSIONS:		TOLERANCES UNLESS OTHERWISE SPECIFIED:		DWG: X.ZHAO 02JUN2011		TE Connectivity	
mm	0 PLC ±	1 PLC ±	2 PLC ±	3 PLC ±	4 PLC ±	5 PLC ±	Harrisburg, PA 17105-3608
	ANGLES	FINISH		CHK: S.XI 02JUN2011	NAME: Ocean Side Feed Applicator		RESTRICTED TO
MATERIAL:				APVD: I. CRUZ 02JUN2011	SIZE: A1	CAGE CODE: 00779	DRAWING NO: ©=2151177
				PRODUCT SPEC	SCALE: 1:2	SHEET: 2 of 4	REV: K
				APPLICATION SPEC	Customer Accessible Production Drawing		

8	7	6	5	4	3	2	1
THIS DRAWING IS UNPUBLISHED.		RELEASED FOR PUBLICATION					
COPYRIGHT 20 BY TYCO ELECTRONICS CORPORATION. ALL RIGHTS RESERVED.							
PART NUMBER	REVISION	DESCRIPTION	FEED TYPE				
2-2151177-2	K	FINE CRIMP HEIGHT ADJUST	PNEUMATIC				
7-2151177-7	F	CRIMP TOOLING KIT	-				

PACIFIC VERSION TERMINATOR INTERFACE ADAPTER

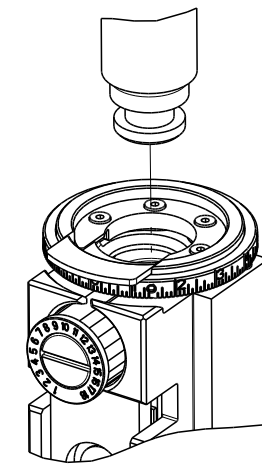

APPLICATOR DATA		
CRIMP	SIZE	TYPE
WIRE	2.79 mm [.110]	F
INSUL	6.60 mm [.260]	O
APPLICATOR INSTRUCTIONS 408-35042		

TERMINAL DATA: TE TERMINAL		TE CRIMP SPECIFICATION	
TERMINAL NAME: STANDARD POWER TIMER TERMINAL			
WIRE STRIP LENGTH		INSULATION DIAMETER RANGE	
4.90-5.50 mm [.193-.217 IN]		∅ 2.20-3.70 mm [.087-.146 IN]	
TERMINAL APPLICATION SPECIFICATION	(A)114-18037	-	-
	(B)114-18388	-	-

TERMINALS APPLIED				SEAL INSULATION DIAMETER RANGE
TE TERMINAL	TE TERMINAL	TE SEAL	TE SEAL	
(A) 969042-1			963244-1	∅ 2.2-3.0mm
(B) 1241414-1			963245-1	∅ 3.4-3.7mm
(B) 1241414-3			1394511-1	∅ 2.0-2.7mm

WIRE SIZE	CRIMP HEIGHT mm [INCH]	CRIMP HEIGHT REFERENCE SETTING
2.50mm2	1.89+/-0.05 [.074+/-0.002]	6.2
1.50mm2	1.64+/-0.05 [.065+/-0.002]	9.7

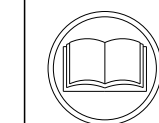

- 1 RECOMMENDED SPARE PARTS
- 2 REFER TO SUPPLIED INSTRUCTION SHEET FOR CLEANING, LUBRICATION AND STORAGE OF APPLICATOR.
- 3 APPLY PART NUMBER 2-23419-6 LOCTITE TO THREADS OF ITEM 242.
- 4 CRIMP HEIGHT REFERENCE SETTING WAS THE SETTING USED WHEN THE APPLICATOR WAS QUALIFIED AT THE FACTORY. ADJUSTMENT MAY BE NECESSARY WHEN RUNNING APPLICATOR IN THE FIELD.
- 5 TERMINAL PITCH NOT COMPATIBLE WITH MECHANICAL FEED.
- 6 APPLY TORO-SEAL IN ALLEN SOCKET TO FILL HOLE AFTER FLAT HD HAS BEEN ADJUSTED TO CORRECT HEIGHT AT QUALIFICATION. APPLY #1-23419-5 LOC-TITE TO THREADS.
- 7. UNLESS SPECIFIED OTHERWISE TORQUE VALUES SHALL BE USED PER DOCUMENT, 101-35000.
- 8 TERMINAL LUBRICANT IS RECOMMENDED.

**\*WARNING**  
ON INSTALLATION, SET WIRE DISC TO CRIMP HEIGHT REFERENCE SETTING FOR LARGEST WIRE SIZE. CRIMP HEIGHT REFERENCE SETTINGS GREATER THAN THE VALUE SHOWN MAY CAUSE DAMAGE TO THE CRIMP TOOLING, REFER TO THE INSTRUCTION SHEET FOR PROPER SETUP AND ADJUSTMENTS.

LOC	DIST	REVISIONS					
A	66	P	LTN	DESCRIPTION	DATE	DWN	APVD
		-		SEE SHEET 1	-	-	-

-	1	2119082-2	CAM, SNAIL, INSULATION ADJUSTMENT	244
-	1	2079764-1	WASHER, WAVE SPRING, CREST-TO-CREST	243
-	1	2119083-1	RETAINER, INSULATION DIAL	242
-	1	7-18023-7	SCR, SKT HD CAP M3 X 4.0	241
-	1	2844940-1	AIR FEED MODULE	238
-	REF	994970-2	COUNTER, MAGNETIC	164
-	1	2119641-2	FEED CAM, AIR FEED	151
-	1	2168083-8	SCR, SKT HD CAP, RoHS, M4 X 16	144
-	4	2168083-9	SCR, SKT HD CAP, RoHS, M4 X 20	143
-	1	1-1803583-0	APPLICATOR BASIC ASSEMBLY, SF	141
-	1	1803516-1	RAM ASSEMBLY, SF PACIFIC	140
-	1	2119955-1	ASSY, LUBRICATOR, SIDE FEED	113
-	1	2844908-1	SCREW, LOCKING	99
-	1	2844907-1	POST, LOCKING	98
-	1	455888-7	SPACER, CRIMPER	82
-	1	1803607-3	DOCUMENTATION PACKAGE	71
-	1	2119791-5	DEPRESSOR, WIRE	70
-	1	2119943-1	WASHER, SPACER	69
-	1	2119740-1	TAG IDENTIFICATION	67
-	2	2168078-1	SCREW, DRIVE, RH, RoHS, 2 x .188	66
-	1	5-18022-5	SCR, HEX HD CAP, M4 X 6.0	59
-	1	985575-3	SCR, FLT SKT HD CAP M3 X 10.0	57
-	1	1338685-1	PAWL, FEED	56
-	2	1-2168083-0	SCR, SKT HD CAP, RoHS, M4 X 10	53
-	1	1803382-2	HOLD DOWN, SPRING LOADED	50
-	1	18023-9	SCR, SKT HD CAP M4 X 6.0	49
-	1	1803602-1	SCR, BHSC, RoHS (M8 X 25)	41
-	1	1-1752356-1	SUPPORT, TERMINAL	34
-	2	2079383-5	SCR, BHSC, RoHS (M4 X 20)	33
-	2	3-2844962-2	SPACER, CYLINDRICAL, STRIP GUIDE	30
-	1	2844992-2	ASSEMBLY, STRIP GUIDE	29
-	1	455888-6	SPACER, CRIMPER	28
-	1	1320928-6	STRIP GUIDE	24
-	1	2168083-2	SCR, SKT HD CAP, RoHS, M4 X 8.0	21
-	2	1-18028-2	WASHER, FLAT, REG M4	20
-	1	2119533-1	STRIPPER, SIDE FEED	19
-	1	2119806-1	INSERT, SHEAR	13
-	1	3-22280-3	SPRING, COMPRESSION	12
-	1	1-356885-4	STOP, SHEAR	11
-	1	2119805-1	SHEAR HOLDER, FRONT	10
-	1	318707-1	FLOATING SHEAR, FRONT	9
1	1	1333229-2	ANVIL, COMBINATION	8
-	1	2-240641-8	SPACER	7
-	1	2119781-5	DEPRESSOR, SHEAR	5
-	1	238011-8	BLOCK, CRIMPER SPACER	4
1	1	1803464-8	CRIMPER, INSULATION O	3
-	1	1-455888-1	SPACER, CRIMPER	2
1	1	456408-3	CRIMPER, WIRE PREMIUM	1

DIMENSIONS:		TOLERANCES UNLESS OTHERWISE SPECIFIED:		DWN X.ZHAO 02JUN2011		TE Connectivity	
mm	0 PLC ±	1 PLC ±	2 PLC ±	3 PLC ±	4 PLC ±	Harrisburg, PA 17105-3608	
MATERIAL:		FINISH:		CHK S.XI 02JUN2011		NAME	
				APVD J. CRUZ 02JUN2011		Ocean Side Feed	
				PRODUCT SPEC		Applicator	
				APPLICATION SPEC		SIZE CAGE CODE DRAWING NO RESTRICTED TO	
				WEIGHT		A1 00779 C=2151177	
				SCALE		Customer Accessible Production Drawing 1:2 SHEET 3 OF 4 REV K	

PACIFIC VERSION  
Shown on sheets 3 of 4 & 4 of 4  
(Atlantic version shown on sheets 1 of 4 & 2 of 4)

LOC		DIST		REVISIONS			
P	LTN	DESCRIPTION	DATE	OWN	APVD		
-	-	SEE SHEET 1	-	-	-		

# FEED TYPE

## PNEUMATIC

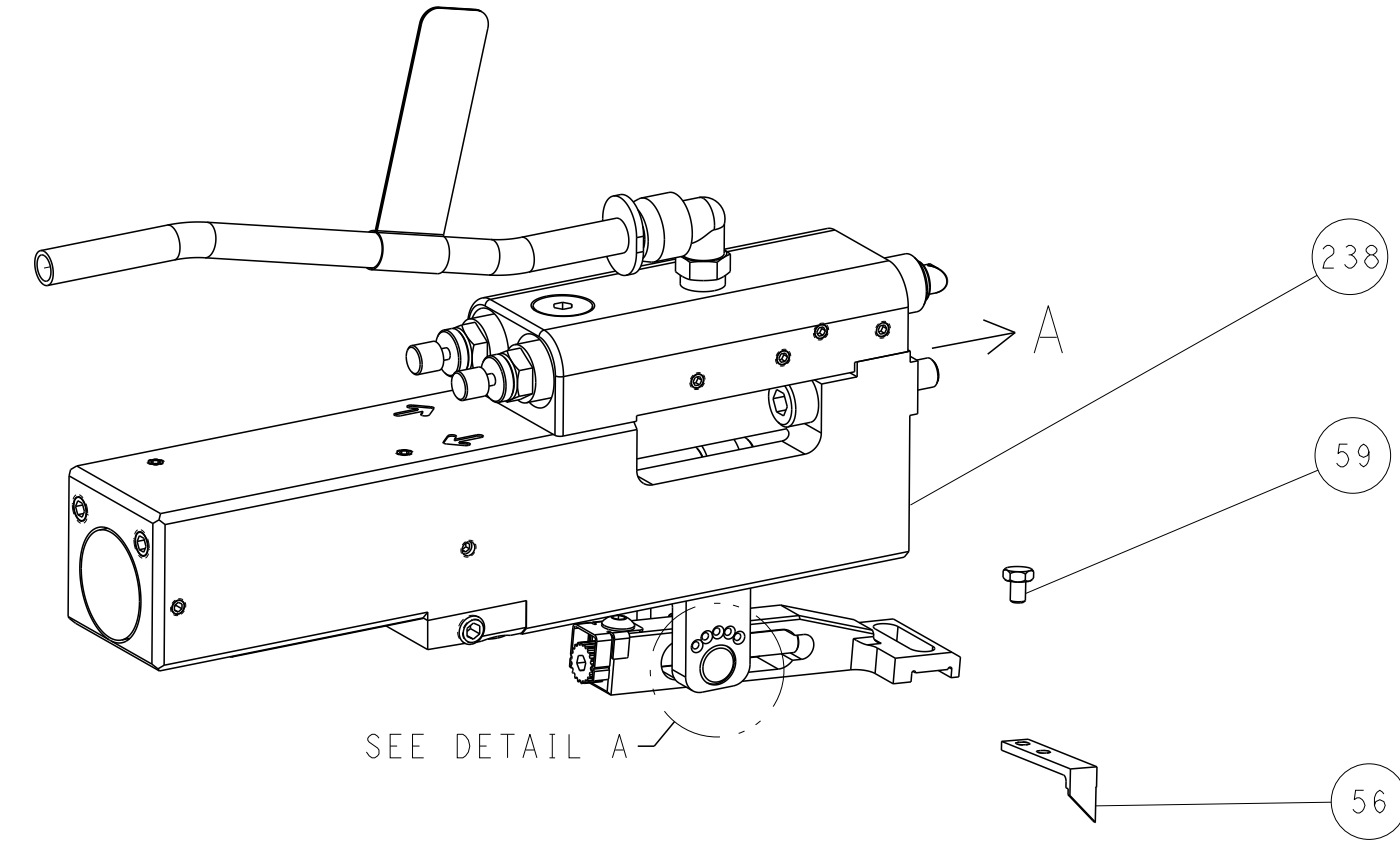

## FEED SPRING SETTING POSITION (SHOWN FROM REAR SIDE)

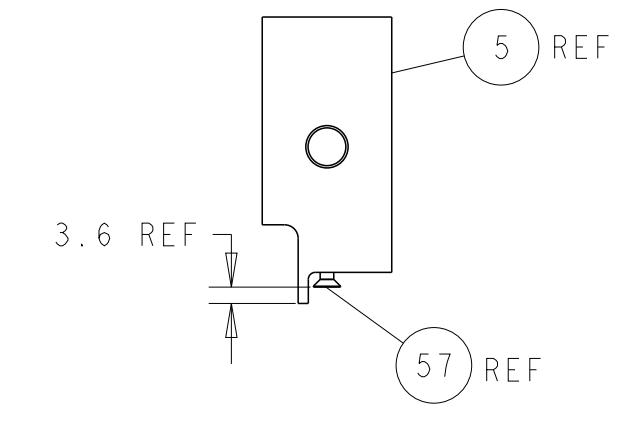
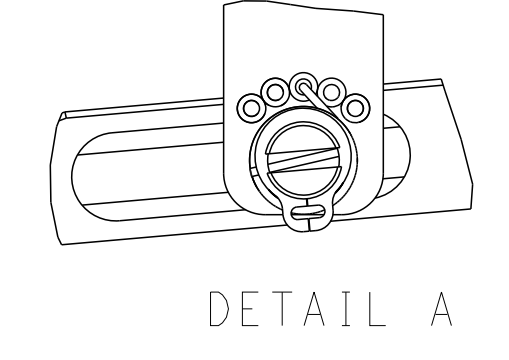

SHEAR DEPRESSOR DETAIL

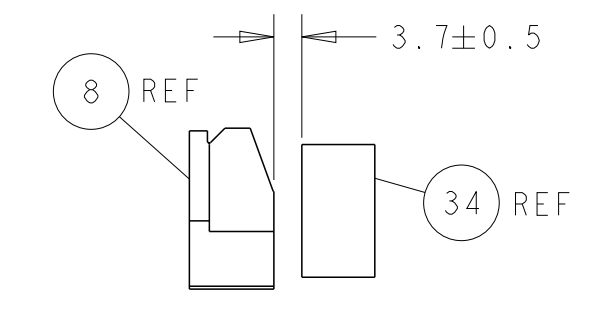

TERMINAL SUPPORT LOCATION

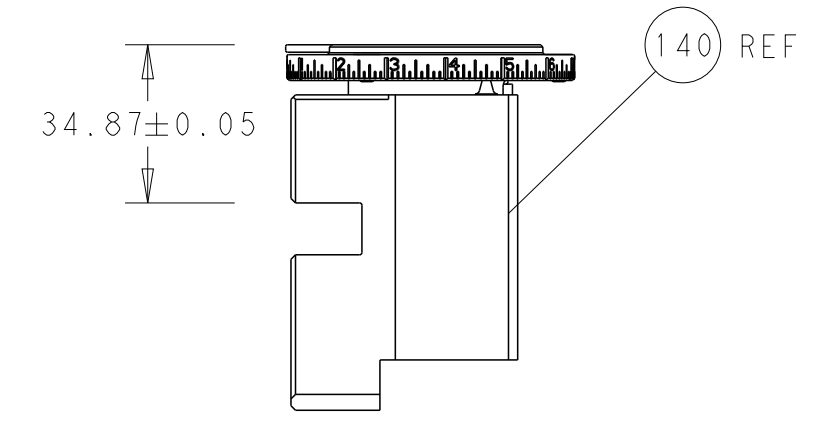

RAM SET-UP

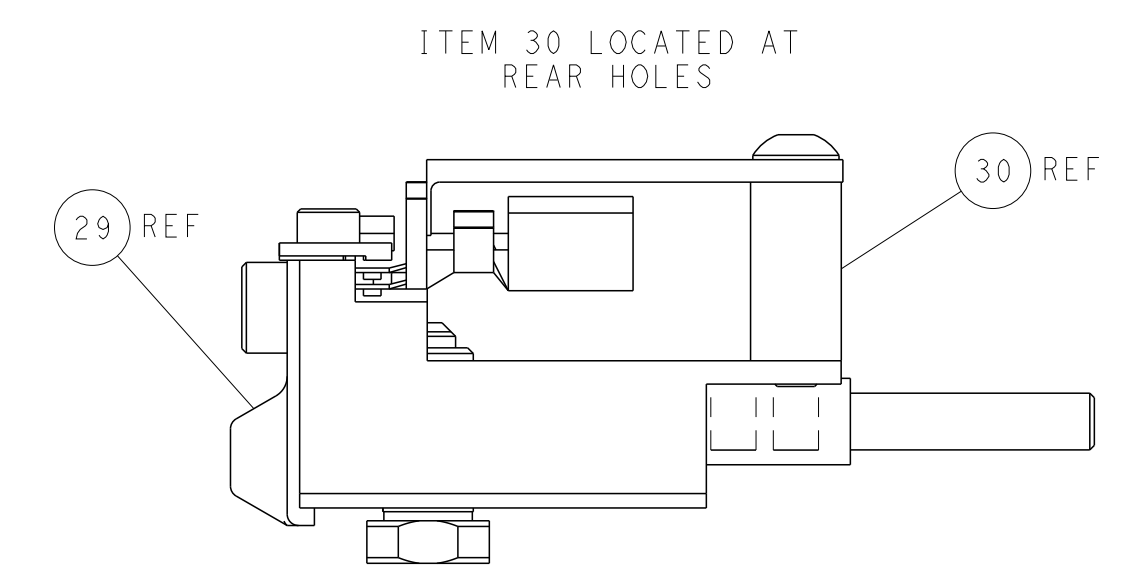

FEED TRACK POSITION GUIDE BY INSULATION BARREL

## CAM POSITION

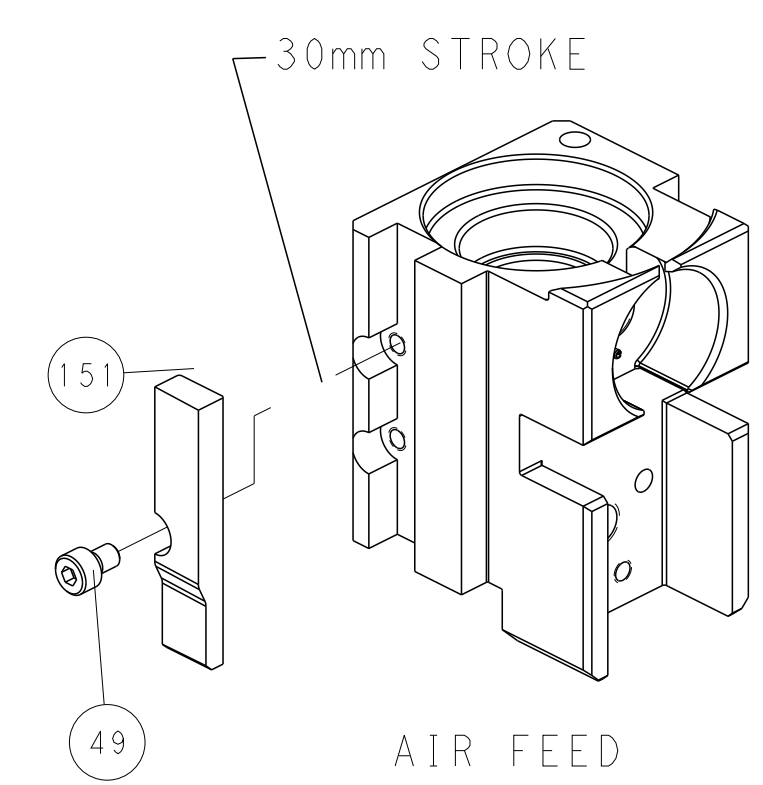

AIR FEED

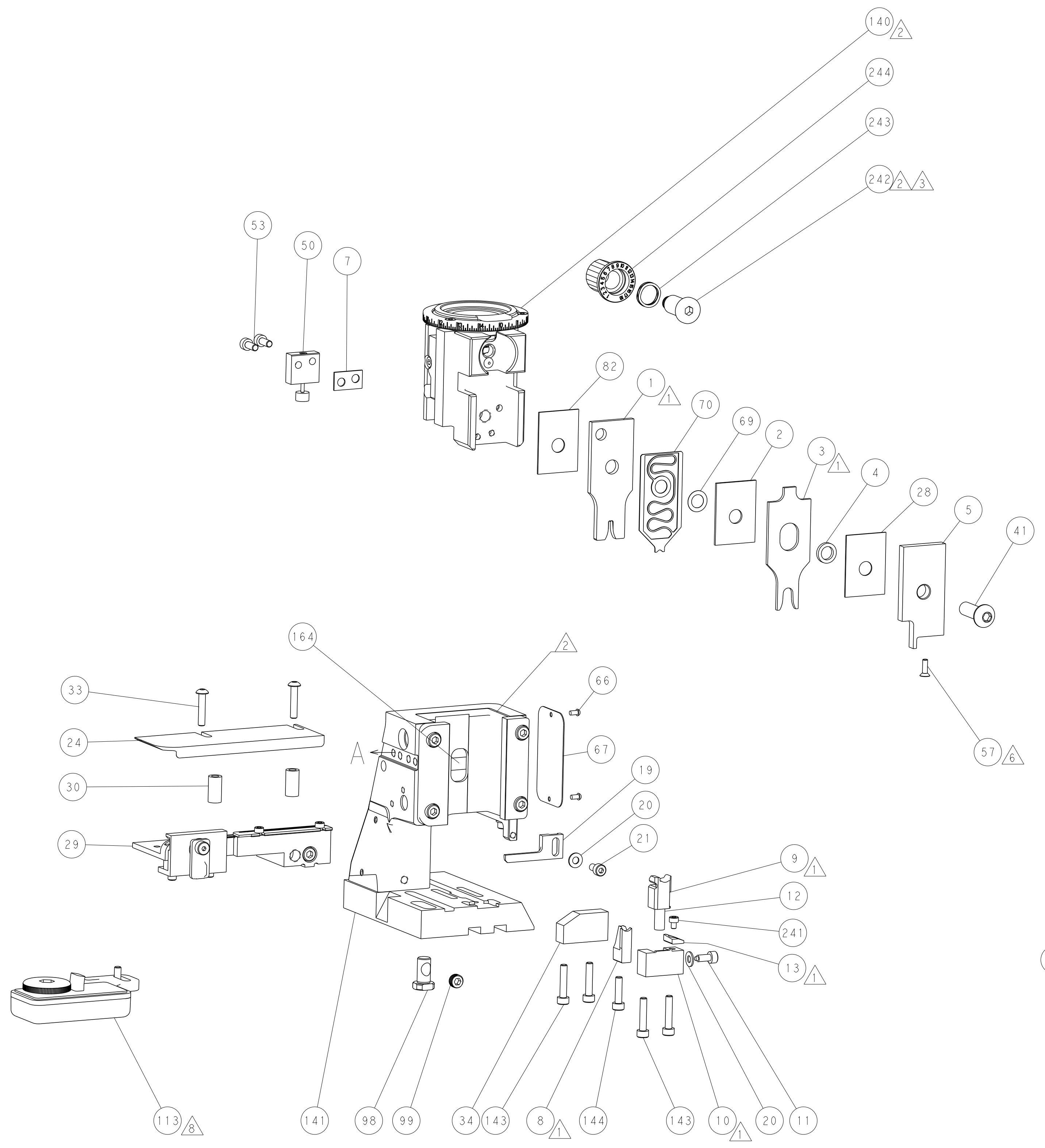

**PACIFIC VERSION**  
 Shown on sheets 3 of 4 & 4 of 4  
 (Atlantic version shown on sheets 1 of 4 & 2 of 4)

DIMENSIONS:		TOLERANCES UNLESS OTHERWISE SPECIFIED:		DWN X.ZHAO 02JUN2011		TE Connectivity	
mm	0 PLC ±	1 PLC ±	2 PLC ±	3 PLC ±	4 PLC ±	Harrisburg, PA 17105-3608	
MATERIAL:	FINISH:	WEIGHT:	SCALE:	APVD I. CRUZ 02JUN2011	NAME	Ocean Side Feed Applicator	
Customer Accessible Production Drawing				SIZE	CAGE CODE	DRAWING NO	RESTRICTED TO
				A1	00779	©=2151177	
				SHEET	4	OF	4
				REV	K		

# Mouser Electronics

Authorized Distributor

Click to View Pricing, Inventory, Delivery & Lifecycle Information:

[TE Connectivity:](#)

[2-2151177-2](#)