

PART NUMBER	REVISION	DESCRIPTION	FEED TYPE
2151151-2	P	FINE CRIMP HEIGHT ADJUST	PNEUMATIC
7-2151151-2	P	PNEUMATIC AND CRIMP TOOLING KIT	PNEUMATIC
7-2151151-7	A	CRIMP TOOLING KIT	-

ATLANTIC VERSION TERMINATOR INTERFACE ADAPTER

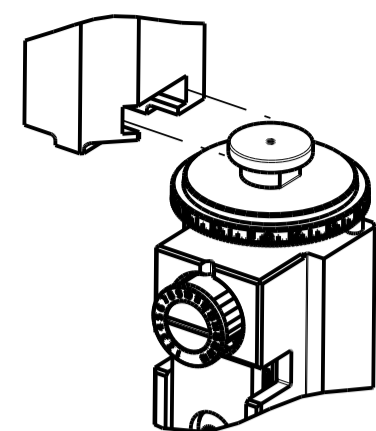

APPLICATOR DATA		
CRIMP	SIZE	TYPE
WIRE	3.30 mm [.130]	F
INSUL	6.86 mm [.270]	O

APPLICATOR INSTRUCTIONS 408-35042

TERMINAL DATA: TE TERMINAL		TE CRIMP SPECIFICATION	
TERMINAL NAME: AMP MCP4.8K FLATCONTACT			
WIRE STRIP LENGTH		TERMINAL INSULATION DIAMETER RANGE	
5.00-5.60 mm [.197-.220 IN]		Ø 3.30-4.50mm [.130-.177 IN]	
TERMINAL APPLICATION SPECIFICATION	114-18037		
TERMINALS APPLIED			
TE TERMINAL	TE TERMINAL	TE SEAL	TE SEAL
969044-1	969044-5		963245
1-969044-5			
			SEAL INSULATION DIAMETER RANGE
			Ø 3.4-3.7mm

TERMINAL DATA: TE TERMINAL		TE CRIMP SPECIFICATION	
TERMINAL NAME: AMP MCP4.8K FLATCONTACT			
WIRE STRIP LENGTH		TERMINAL INSULATION DIAMETER RANGE	
4.70-5.30 [.185-.209 IN]		Ø 3.30-4.50mm [.130-.177 IN]	
TERMINAL APPLICATION SPECIFICATION	114-18388		
TERMINALS APPLIED			
TE TERMINAL	TE TERMINAL	TE SEAL	TE SEAL
1241416-1	1241416-3	963245	1394512
			1719043-1
			SEAL INSULATION DIAMETER RANGE
			Ø 3.4-3.7mm
			Ø 4.0-4.5mm

WIRE SIZE	CRIMP HEIGHT mm [INCH]	CRIMP HEIGHT REFERENCE SETTING
4.00mm2	2.22+/-0.05 [.087+/- .002]	5.0

WIRE SIZE	CRIMP HEIGHT mm [INCH]	CRIMP HEIGHT REFERENCE SETTING
4.00mm2	2.22+/-0.05 [.087+/- .002]	5.0
3.00mm2	2.13+/-0.05 [.084+/- .002]	6.0

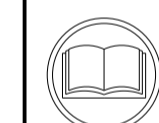

- RECOMMENDED SPARE PARTS
- REFER TO SUPPLIED INSTRUCTION SHEET FOR CLEANING, LUBRICATION AND STORAGE OF APPLICATOR.
- APPLY PART NUMBER 2-23419-6 LOCTITE TO THREADS OF ITEM 242.
- CRIMP HEIGHT REFERENCE SETTING WAS THE SETTING USED WHEN THE APPLICATOR WAS QUALIFIED AT THE FACTORY. ADJUSTMENT MAY BE NECESSARY WHEN RUNNING APPLICATOR IN THE FIELD.
- TERMINAL PITCH NOT COMPATIBLE WITH MECHANICAL FEED.
- 6. UNLESS SPECIFIED OTHERWISE TORQUE VALUES SHALL BE USED PER DOCUMENT, 101-35000.
- APPLY TORO-SEAL IN ALLEN SOCKET TO FILL HOLE AFTER ITEM #57 HAS BEEN ADJUSTED TO CORRECT HEIGHT AT QUALIFICATION.
- THIS CRIMP PARAMETER IS PROVIDED TO MEET A CUSTOM AND UNIQUE CUSTOMER REQUIREMENT. IT HAS BEEN EVALUATED AND IS CONDITIONALLY SPECIFIED BY TE CONNECTIVITY. THIS CUSTOMIZED CRIMP PARAMETER IS NOT LISTED AS AN APPROVED APPLICATION WITHIN A TE CONNECTIVITY APPLICATION SPECIFICATION. **TE CONNECTIVITY EXPRESSLY DISCLAIMS ANY AND ALL WARRANTIES THAT THE PRODUCT WILL PERFORM SIMILARLY TO VALIDATED AND APPROVED APPLICATIONS, AS STATED WITHIN TE CONNECTIVITY APPLICATION SPECIFICATIONS, INCLUDING BUT NOT LIMITED TO IMPLIED WARRANTIES OF MERCHANTABILITY OR FITNESS FOR PARTICULAR PURPOSE.** AS SUCH, IT IS HIGHLY RECOMMENDED THAT THE CUSTOMER PERFORM FURTHER DETAILED EVALUATION TO ASSESS PRODUCT PERFORMANCE IN THE SPECIFIC APPLICATION.
- TERMINAL LUBRICANT IS RECOMMENDED.

***WARNING**
ON INSTALLATION, SET WIRE DISC TO CRIMP HEIGHT REFERENCE SETTING FOR LARGEST WIRE SIZE. CRIMP HEIGHT REFERENCE SETTINGS GREATER THAN THE VALUE SHOWN MAY CAUSE DAMAGE TO THE CRIMP TOOLING. REFER TO THE INSTRUCTION SHEET FOR PROPER SETUP AND ADJUSTMENTS.

LOC	DIST	REV	LTN	DESCRIPTION	DATE	OWN	APPD
A	66	N		ECR-19-005396	03APR2019	LG	TE
		N1		ECR-20-002074	17FEB2020	MZ	YY
		P		ECR-20-017184	03DEC2020	JWC	TE
		P1		ECR-21-006043	04JUN2021	LJ	YY

-	1	1	2119641-1	FEED CAM, AIR FEED	248	
-	1	1	2119082-2	CAM, SNAIL, INSULATION ADJUSTMENT	244	
-	1	1	2079764-1	WASHER, WAVE SPRING, CREST-TO-CREST	243	
-	1	1	2119083-1	RETAINER, INSULATION DIAL	242	
-	1	1	7-18023-7	SCR, SKT HD CAP M3 X 4.0	241	
-	1	1	2844940-1	AIR FEED MODULE	238	
-	REF	REF	994970-2	COUNTER, MAGNETIC	164	
-	1	1	1-22281-8	SPRING, COMPRESSION	121	
-	1	1	2119955-1	ASSY, LUBRICATOR, SIDE FEED	113	
-	1	1	2844908-1	SCREW, LOCKING	99	
-	1	1	2844907-1	POST, LOCKING	98	
-	1	1	2-690438-8	FRONT STRIP GUIDE	96	
-	2	2	2168083-1	SCR, SKT HD CAP, RoHS, M3 X 8.0	95	
-	1	1	2168083-6	SCR, SKT HD CAP, RoHS, M5 X 65	93	
-	1	1	455888-5	SPACER, CRIMPER	82	
-	1	1	1803607-3	DOCUMENTATION PACKAGE	71	
-	1	1	2119740-1	TAG IDENTIFICATION	67	
-	2	2	2168078-1	SCREW, DRIVE, RH, RoHS, 2 x .188	66	
-	2	2	2-18032-5	SCR, SET, FLT PNT, M5 X 20.0	61	
-	1	1	2168083-2	SCR, SKT HD CAP, RoHS, M4 X 8.0	60	
-	1	1	5-18022-5	SCR, HEX HD CAP, M4 X 6.0	59	
-	1	1	1-2168083-3	SCR, SKT HD CAP, RoHS, M3 X 16	57	
-	1	1	1338683-8	FEED PAWL	56	
-	4	4	2168083-3	SCR, SKT HD CAP, RoHS, M4 X 12.0	54	
-	2	2	1-2168083-0	SCR, SKT HD CAP, RoHS, M4 X 10	53	
-	2	2	5018030-1	NUT, HEX, REG, RoHS, M3	52	
-	1	1	811242-6	BUMPER, HOLD DOWN	51	
-	1	1	690753-2	SPACER, TONKER	50	
-	1	1	18023-9	SCR, SKT HD CAP M4 X 6.0	49	
-	1	1	1803583-3	APPLICATOR BASIC ASSEMBLY, SF	46	
-	1	1	1803515-1	RAM ASSEMBLY, SF ATLANTIC	44	
-	1	1	1803602-1	SCR, BHSC, RoHS (M8 X 25)	41	
-	1	1	1-1752356-2	SUPPORT, TERMINAL	34	
-	2	2	2079383-5	SCR, BHSC, RoHS (M4 X 20)	33	
-	2	2	3-2844962-3	SPACER, CYLINDRICAL, STRIP GUIDE	30	
-	1	1	2-2844938-3	PLATE, STRIP GUIDE	29	
-	1	1	455888-3	SPACER, CRIMPER	28	
-	2	2	22283-1	SPRING, COMPRESSION	27	
-	1	1	356835-1	LEVER, DRAG RELEASE	26	
-	1	1	240792-1	DRAG, TERMINAL	25	
-	1	1	1320928-2	STRIP GUIDE	24	
-	1	1	980371-4	SCR, SKT HD SHLDR 5.0 DIA X 6.0	23	
-	1	1	2168083-2	SCR, SKT HD CAP, RoHS, M4 X 8.0	21	
-	1	1	1-18028-2	WASHER, FLAT, REG M4	20	
-	1	1	2119533-2	STRIPPER, SIDE FEED	19	
-	1	1	2119806-1	INSERT, SHEAR	13	
-	1	1	4-22280-9	SPRING, COMPRESSION	12	
-	1	1	1-356885-0	STOP, SHEAR	11	
-	1	1	2119805-2	SHEAR HOLDER, FRONT	10	
-	1	1	318059-4	FLOATING SHEAR, FRONT	9	
-	1	2	1	1333229-1	ANVIL, COMBINATION	8
-	1	1	1803080-2	DEPRESSOR, SHEAR	5	
-	1	1	5-238011-5	BLOCK, CRIMPER SPACER	4	
-	1	2	1	2-2119784-8	CRIMPER, INSULATION O PREMIUM	3
-	1	1	1-455888-1	SPACER, CRIMPER	2	
-	1	2	1	456410-4	CRIMPER, WIRE PREMIUM	1

ATLANTIC VERSION
Shown on sheets 1 of 4 & 2 of 4
(Pacific version shown on sheets 3 of 4 & 4 of 4)

DIMENSIONS:		TOLERANCES UNLESS OTHERWISE SPECIFIED:		MATERIAL:		FINISH:	
mm	0 PLC ±	1 PLC ±	2 PLC ±	3 PLC ±	4 PLC ±	ANGLES ±	
Customer Accessible Production Drawing				SCALE	1:2	SHEET	1 of 4

REVISONS		DATE	OWN	APVD
LOC	DIST			
A	66			
P	LTN	DESCRIPTION		
		SEE SHEET 1		

FEED TYPE

PNEUMATIC

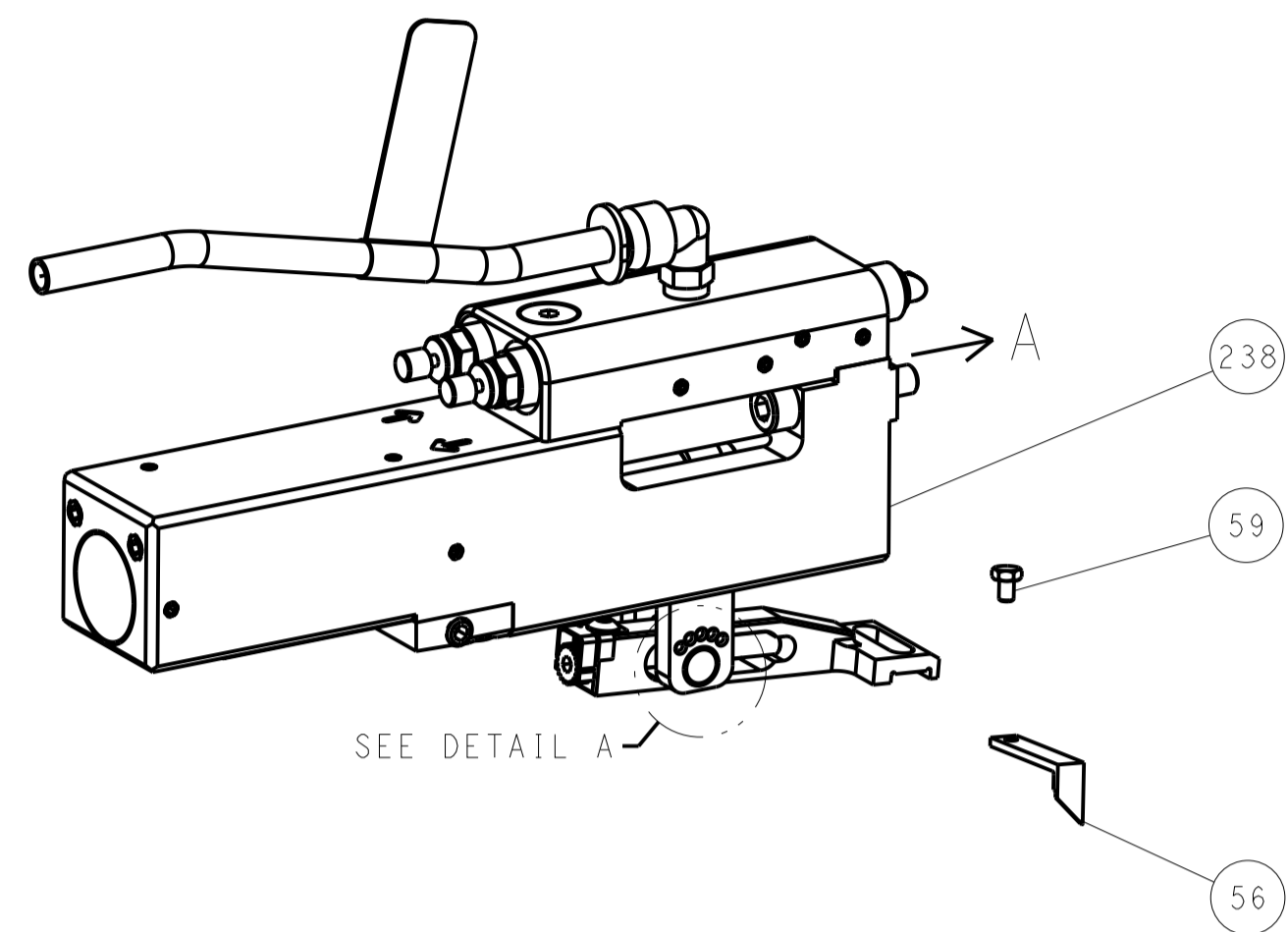

SEE DETAIL A

FEED SPRING SETTING POSITION
(SHOWN FROM REAR SIDE)

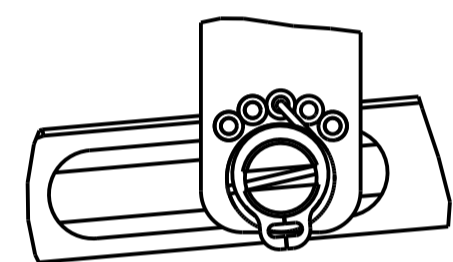

DETAIL A

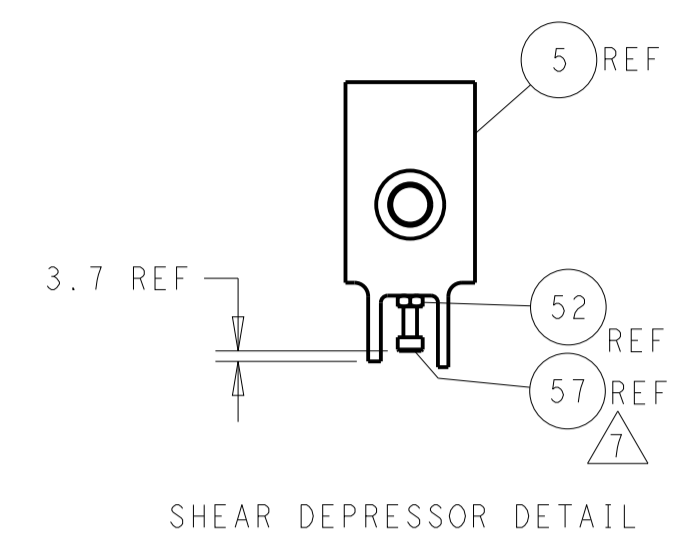

SHEAR DEPRESSOR DETAIL

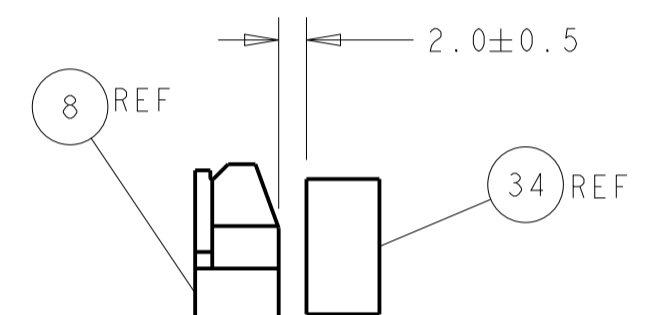
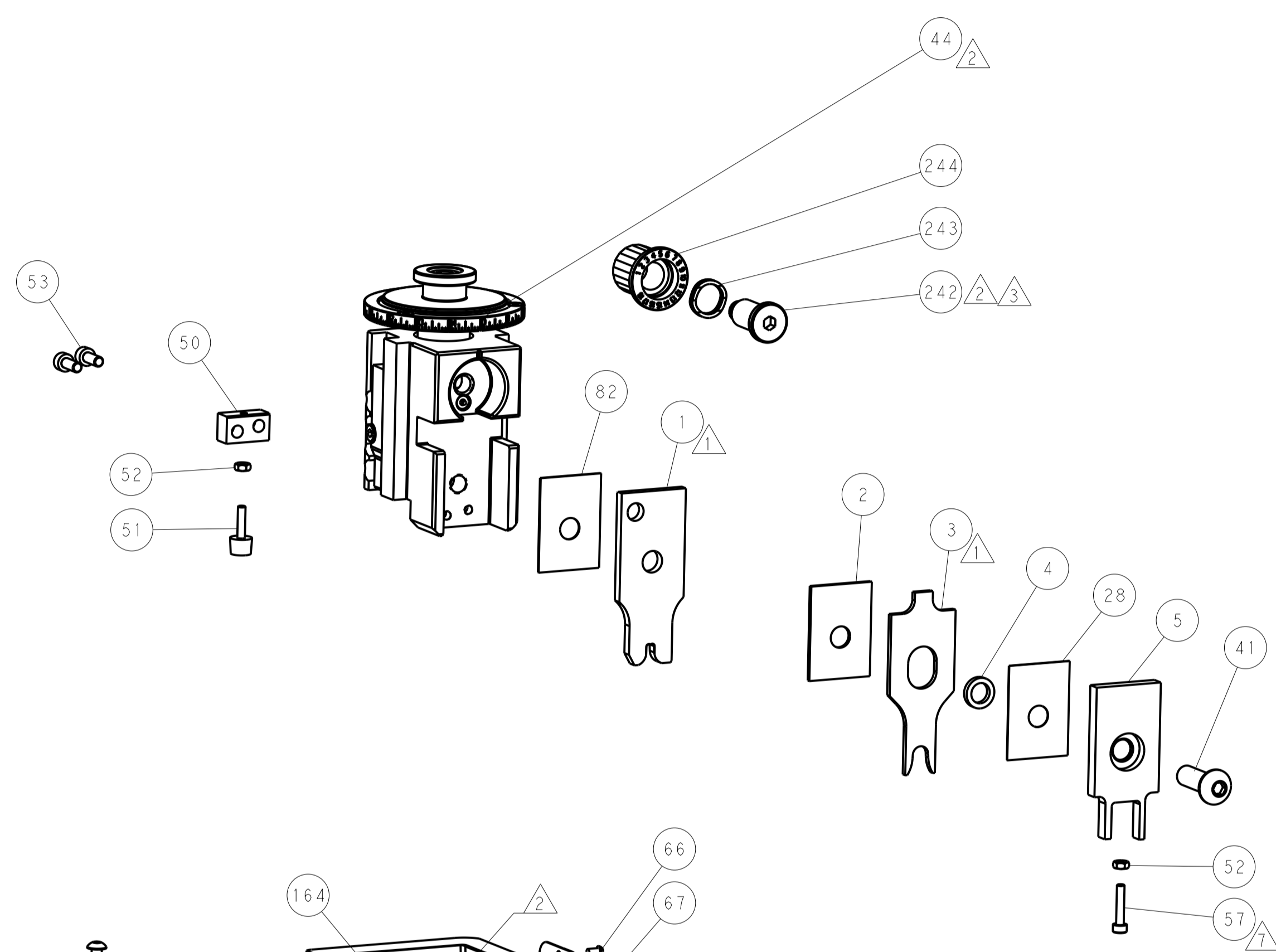

TERMINAL SUPPORT LOCATION

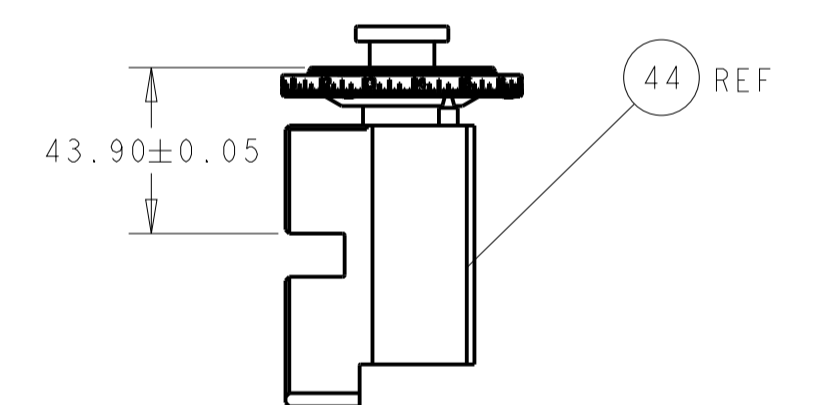

RAM SET-UP

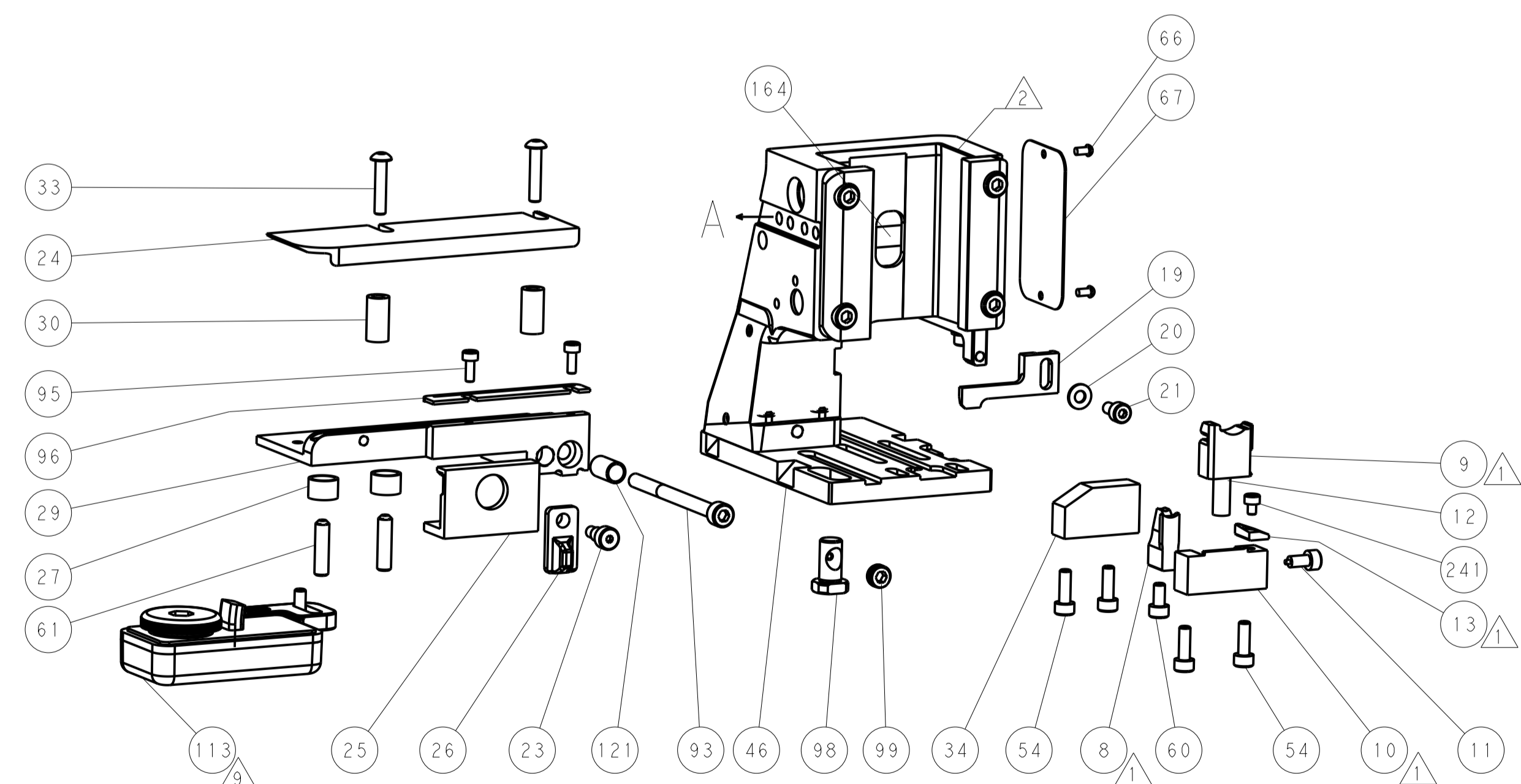

CAM POSITION

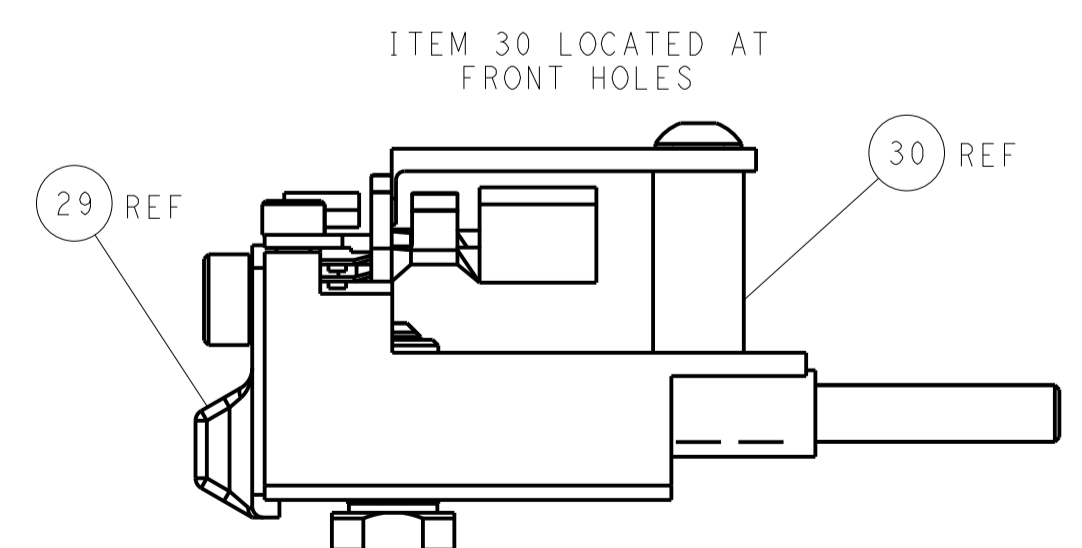
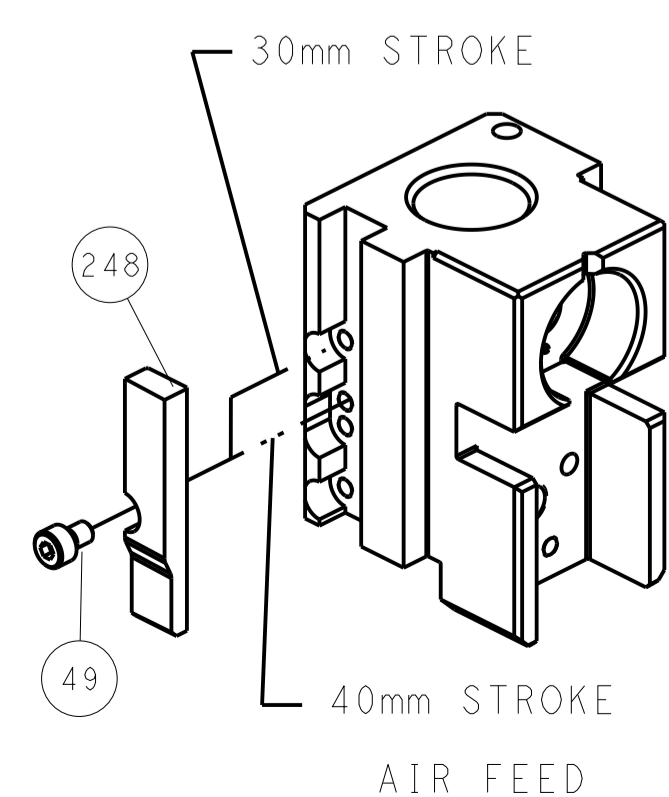

FEED TRACK POSITION
GUIDE BY INSULATION BARREL

ATLANTIC VERSION
 Shown on sheets 1 of 4 & 2 of 4
 (Pacific version shown on sheets 3 of 4 & 4 of 4)

DIMENSIONS:		TOLERANCES UNLESS OTHERWISE SPECIFIED:		DWN: HOFFNER 18AUG2011		TE Connectivity	
mm	0 PLC ±	1 PLC ±	2 PLC ±	3 PLC ±	4 PLC ±	Harrisburg, PA 17105-3608	
MATERIAL:		FINISH:		CHG: T. ELBIN 19AUG2011		NAME: Ocean Side Feed Applicator	
				APVD: T. ELBIN 19AUG2011		SIZE: CAGE CODE: DRAWING NO: A1 00779 ©=2151151	
				PRODUCT SPEC:		RESTRICTED TO:	
				APPLICATION SPEC:		Customer Accessible Production Drawing	
				WEIGHT:		SCALE: 1:2 SHEET 2 OF 4 REV: P1	
				ANGLES:		SHEETS 3 & 4 ARE NOT REQUIRED FOR ATLANTIC VERSION	

THIS DRAWING IS UNPUBLISHED.	RELEASED FOR PUBLICATION		
COPYRIGHT © BY TYCO ELECTRONICS CORPORATION. ALL RIGHTS RESERVED.			
PART NUMBER	REVISION	DESCRIPTION	FEED TYPE
2-2151151-2	P	FINE CRIMP HEIGHT ADJUST	PNEUMATIC
7-2151151-7	A	CRIMP TOOLING KIT	-

PACIFIC VERSION TERMINATOR
INTERFACE ADAPTER

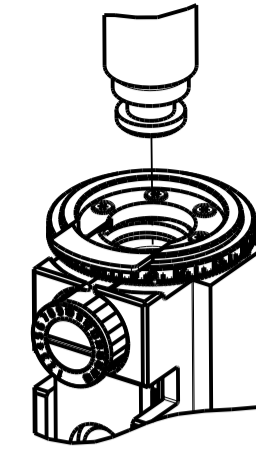

APPLICATOR DATA		
CRIMP	SIZE	TYPE
WIRE	3.30 mm [1.30]	F
INSUL	6.86 mm [2.70]	Q
APPLICATOR INSTRUCTIONS 408-35042		

TERMINAL DATA: TE TERMINAL		TE CRIMP SPECIFICATION	
TERMINAL NAME: AMP MCP4.8K FLATCONTACT			
WIRE STRIP LENGTH		INSULATION DIAMETER RANGE	
5.00-5.60 mm [1.97-.220 IN]		∅3.30-4.50mm [1.30-.177 IN]	
TERMINAL APPLICATION SPECIFICATION	114-18037		
TERMINALS APPLIED			
TE TERMINAL	TE TERMINAL	TE SEAL	TE SEAL
969044-1	969044-5		963245
1-969044-5			

TERMINAL DATA: TE TERMINAL		TE CRIMP SPECIFICATION	
TERMINAL NAME: AMP MCP4.8K FLATCONTACT			
WIRE STRIP LENGTH		INSULATION DIAMETER RANGE	
4.70-5.30 [1.85-.209 IN]		∅3.30-4.50mm [1.30-.177 IN]	
TERMINAL APPLICATION SPECIFICATION	114-18388		
TERMINALS APPLIED			
TE TERMINAL	TE TERMINAL	TE SEAL	TE SEAL
1241416-1	1241416-3		1394512
			1719043-1

WIRE SIZE	CRIMP HEIGHT mm [INCH]	CRIMP HEIGHT REFERENCE SETTING
4.00mm2	2.22+/-0.05 [1.087+/-0.02]	5.0

WIRE SIZE	CRIMP HEIGHT mm [INCH]	CRIMP HEIGHT REFERENCE SETTING
4.00mm2	2.22+/-0.05 [1.087+/-0.02]	5.0
3.00mm2	2.13+/-0.05 [1.084+/-0.02]	6.0

- RECOMMENDED SPARE PARTS
- REFER TO SUPPLIED INSTRUCTION SHEET FOR CLEANING, LUBRICATION AND STORAGE OF APPLICATOR.
- APPLY PART NUMBER 2-23419-6 LOCTITE TO THREADS OF ITEM 242.
- CRIMP HEIGHT REFERENCE SETTING WAS THE SETTING USED WHEN THE APPLICATOR WAS QUALIFIED AT THE FACTORY. ADJUSTMENT MAY BE NECESSARY WHEN RUNNING APPLICATOR IN THE FIELD.
- TERMINAL PITCH NOT COMPATIBLE WITH MECHANICAL FEED.
- 6. UNLESS SPECIFIED OTHERWISE TORQUE VALUES SHALL BE USED PER DOCUMENT, 101-35000.
- APPLY TORO-SEAL IN ALLEN SOCKET TO FILL HOLE AFTER ITEM #57 HAS BEEN ADJUSTED TO CORRECT HEIGHT AT QUALIFICATION.
- THIS CRIMP PARAMETER IS PROVIDED TO MEET A CUSTOM AND UNIQUE CUSTOMER REQUIREMENT. IT HAS BEEN EVALUATED AND IS CONDITIONALLY SPECIFIED BY TE CONNECTIVITY. THIS CUSTOMIZED CRIMP PARAMETER IS NOT LISTED AS AN APPROVED APPLICATION WITHIN A TE CONNECTIVITY APPLICATION SPECIFICATION. **TE CONNECTIVITY EXPRESSLY DISCLAIMS ANY AND ALL WARRANTIES THAT THE PRODUCT WILL PERFORM SIMILARLY TO VALIDATED AND APPROVED APPLICATIONS, AS STATED WITHIN TE CONNECTIVITY APPLICATION SPECIFICATIONS, INCLUDING BUT NOT LIMITED TO IMPLIED WARRANTIES OF MERCHANTABILITY OR FITNESS FOR PARTICULAR PURPOSE.** AS SUCH, IT IS HIGHLY RECOMMENDED THAT THE CUSTOMER PERFORM FURTHER DETAILED EVALUATION TO ASSESS PRODUCT PERFORMANCE IN THE SPECIFIC APPLICATION.
- TERMINAL LUBRICANT IS RECOMMENDED.

***WARNING**
ON INSTALLATION, SET WIRE DISC TO CRIMP HEIGHT REFERENCE SETTING FOR LARGEST WIRE SIZE. CRIMP HEIGHT REFERENCE SETTINGS GREATER THAN THE VALUE SHOWN MAY CAUSE DAMAGE TO THE CRIMP TOOLING. REFER TO THE INSTRUCTION SHEET FOR PROPER SETUP AND ADJUSTMENTS.

ENTRY LEVEL APPLICATOR		ITEM SUBSTITUTION LIST		
PART NUMBER	SAME AS	ITEM	ITEM DESCRIPTION	SUBSTITUTE PART NUMBER
8-2151151-1	2151151-1	1	WIRE CRIMPER	1803551-4
8-2151151-2	2151151-2	3	INSULATION CRIMPER	2-1803604-8
9-2151151-1	2-2151151-1	46	BASIC SUB -ASSEMBLY	1803940-9
9-2151151-2	2-2151151-2	141	BASIC SUB -ASSEMBLY	1-1803940-0
			LUBRICATOR	DELETE

PACIFIC VERSION
Shown on sheets 3 of 4 & 4 of 4
(Atlantic version shown on sheets 1 of 4 & 2 of 4)

LOC	DIST	REV	LTN	DESCRIPTION	DATE	OWN	APVD
A	66	-	-	SEE SHEET 1	-	-	-

-	1	2119082-2	CAM, SNAIL, INSULATION ADJUSTMENT	244	
-	1	2079764-1	WASHER, WAVE SPRING, CREST-TO-CREST	243	
	-	1	2119083-1	RETAINER, INSULATION DIAL	242
-	1	7-18023-7	SCR, SKT HD CAP M3 X 4.0	241	
-	1	2844940-1	AIR FEED MODULE	238	
-	REF	994970-2	COUNTER, MAGNETIC	164	
-	1	2119641-2	FEED CAM, AIR FEED	151	
-	1	2168083-8	SCR, SKT HD CAP, RoHS, M4 X 16	144	
-	4	2168083-9	SCR, SKT HD CAP, RoHS, M4 X 20	143	
-	1	1803583-4	APPLICATOR BASIC ASSEMBLY, SF	141	
-	1	1803516-1	RAM ASSEMBLY, SF PACIFIC	140	
-	1	1-22281-8	SPRING, COMPRESSION	121	
	-	1	2119955-1	ASSY, LUBRICATOR, SIDE FEED	113
-	1	2844908-1	SCREW, LOCKING	99	
-	1	2844907-1	POST, LOCKING	98	
-	1	2-690438-8	FRONT STRIP GUIDE	96	
-	2	2168083-1	SCR, SKT HD CAP, RoHS, M3 X 8.0	95	
-	1	2168083-6	SCR, SKT HD CAP, RoHS, M5 X 65	93	
-	1	455888-5	SPACER, CRIMPER	82	
-	1	1803607-3	DOCUMENTATION PACKAGE	71	
-	1	2119740-1	TAG, IDENTIFICATION	67	
-	2	2168078-1	SCREW, DRIVE, RH, RoHS, 2 x .188	66	
-	2	2-18032-5	SCR, SET, FLT PNT, M5 X 20.0	61	
-	1	5-18022-5	SCR, HEX HD CAP, M4 X 6.0	59	
	-	1	1-2168083-3	SCR, SKT HD CAP, RoHS, M3 X 16	57
-	1	1338683-8	FEED PAWL	56	
-	2	1-2168083-0	SCR, SKT HD CAP, RoHS, M4 X 10	53	
-	2	5018030-1	NUT, HEX, REG, RoHS, M3	52	
-	1	811242-6	BUMPER, HOLD DOWN	51	
-	1	690753-2	SPACER, TONKER	50	
-	1	18023-9	SCR, SKT HD CAP M4 X 6.0	49	
-	1	1803602-1	SCR, BHSC, RoHS (M8 X 25)	41	
-	1	1-1752356-2	SUPPORT, TERMINAL	34	
-	2	2079383-5	SCR, BHSC, RoHS (M4 X 20)	33	
-	2	3-2844962-3	SPACER, CYLINDRICAL, STRIP GUIDE	30	
-	1	2-2844938-3	PLATE, STRIP GUIDE	29	
-	1	455888-3	SPACER, CRIMPER	28	
-	2	22283-1	SPRING, COMPRESSION	27	
-	1	356835-1	LEVER, DRAG RELEASE	26	
-	1	240792-1	DRAG, TERMINAL	25	
-	1	1320928-2	STRIP GUIDE	24	
-	1	980371-4	SCR, SKT HD SHLDR 5.0 DIA X 6.0	23	
-	1	2168083-2	SCR, SKT HD CAP, RoHS, M4 X 8.0	21	
-	1	1-18028-2	WASHER, FLAT, REG M4	20	
-	1	2119533-2	STRIPPER, SIDE FEED	19	
	-	1	2119806-1	INSERT, SHEAR	13
-	1	4-22280-9	SPRING, COMPRESSION	12	
-	1	1-356885-0	STOP, SHEAR	11	
	-	1	2119805-2	SHEAR HOLDER, FRONT	10
	-	1	318059-4	FLOATING SHEAR, FRONT	9
	1	1	1333229-1	ANVIL, COMBINATION	8
-	1	1803080-2	DEPRESSOR, SHEAR	5	
-	1	5-238011-5	BLOCK, CRIMPER SPACER	4	
	1	1	2-2119784-8	CRIMPER, INSULATION O PREMIUM	3
-	1	1	1-455888-1	SPACER, CRIMPER	2
	1	1	456410-4	CRIMPER, WIRE PREMIUM	1

DIMENSIONS:		TOLERANCES UNLESS OTHERWISE SPECIFIED:		OWN	18AUG2011	TE Connectivity Harrisburg, PA 17105-3608
mm	0 PLC ± 2 PLC ± 3 PLC ± 4 PLC ± ANGLES	±	±	CHK	19AUG2011	
MATERIAL:		FINISH:		APVD	19AUG2011	NAME
				PRODUCT SPEC		Ocean Side Feed
				APPLICATION SPEC		Applicator
				SIZE	CAGE CODE	DRAWING NO
				WT	00779	2151151
				Customer Accessible Production Drawing		SCALE 1:2 SHEET 3 OF 4 REV P1

LOC	DIST	REVISIONS			
A	66	REV	DATE	BY	APPV
		1	SEE SHEET 1		

FEED TYPE

PNEUMATIC

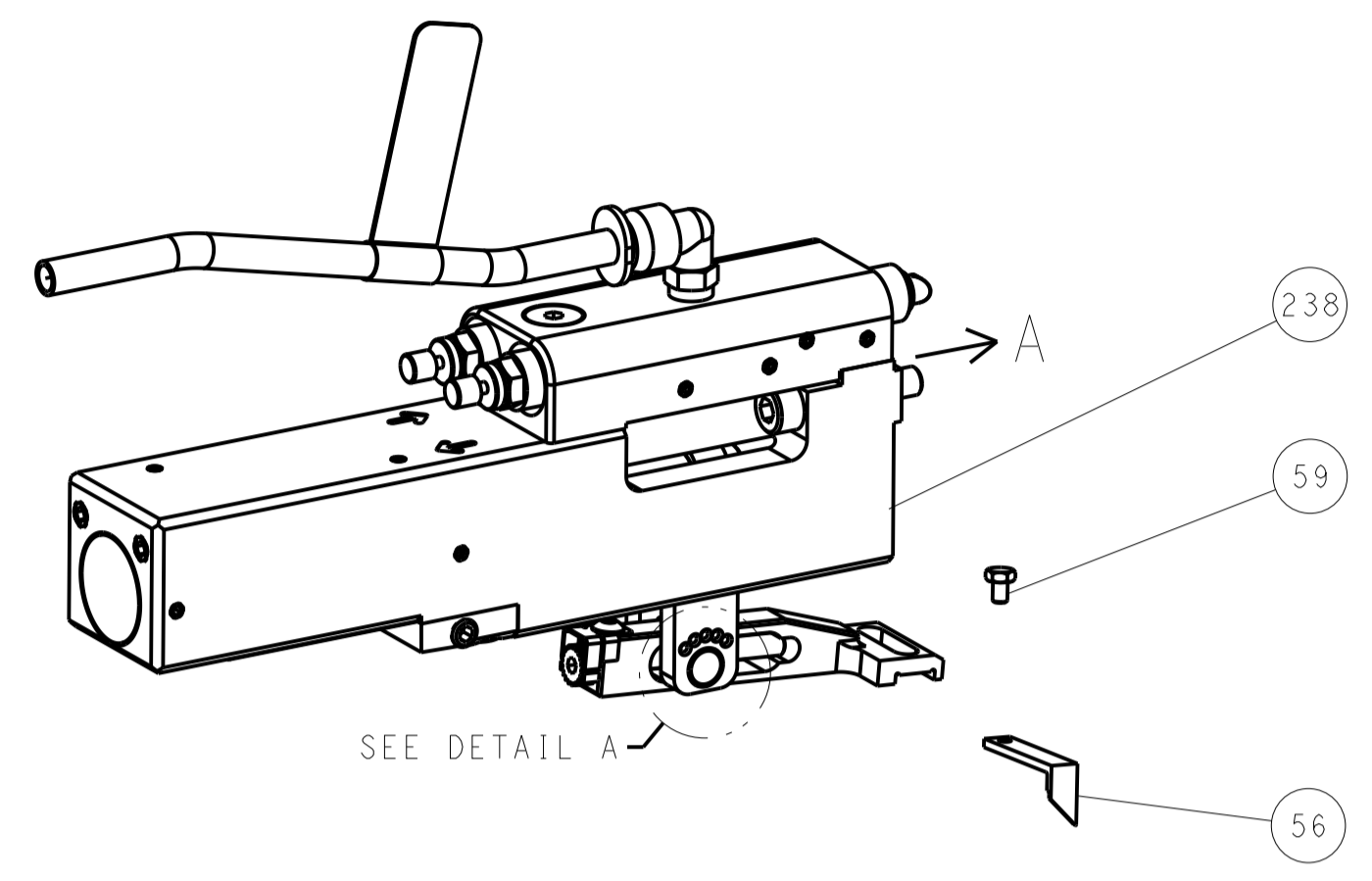

SEE DETAIL A

FEED SPRING SETTING POSITION (SHOWN FROM REAR SIDE)

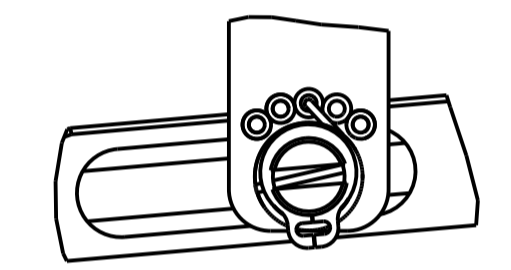

DETAIL A

CAM POSITION

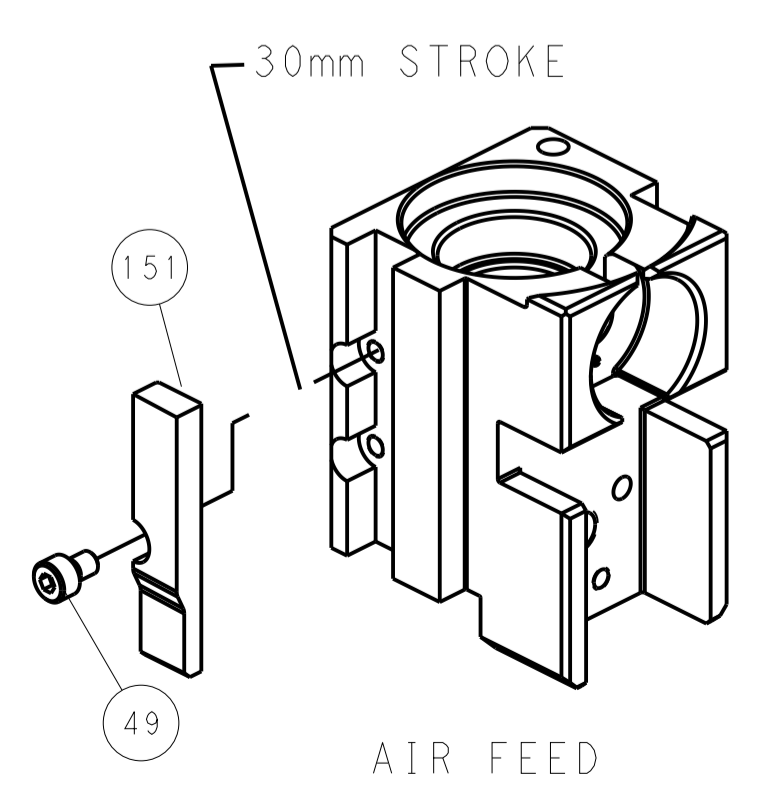

AIR FEED

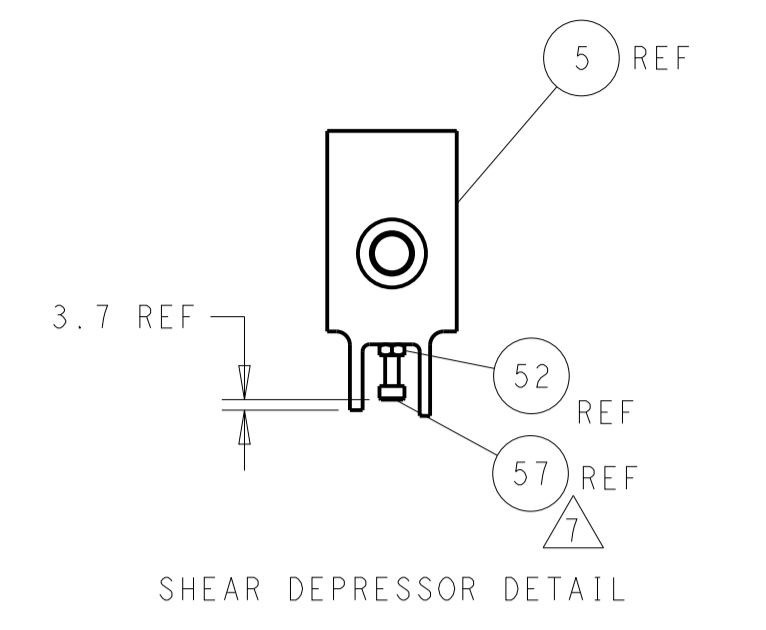
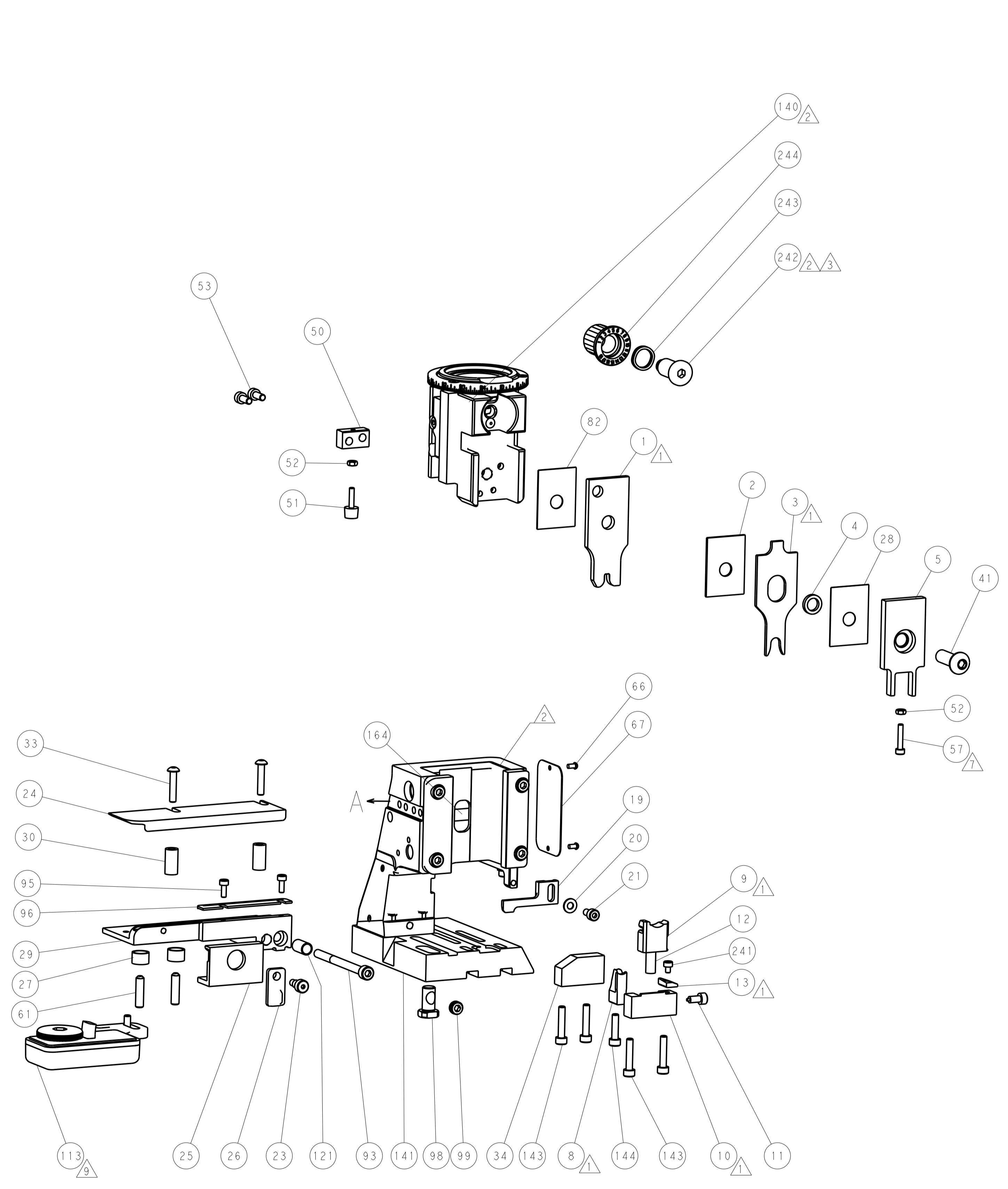

SHEAR DEPRESSOR DETAIL

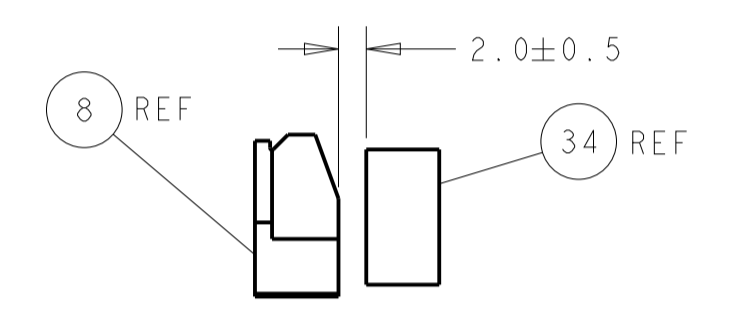

TERMINAL SUPPORT LOCATION

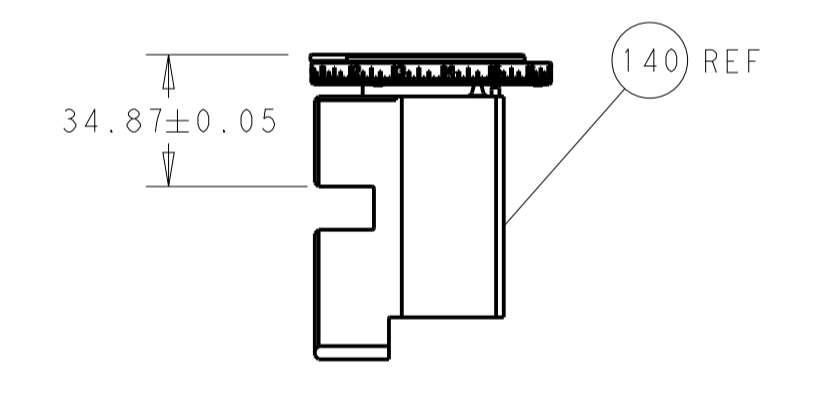

RAM SET-UP

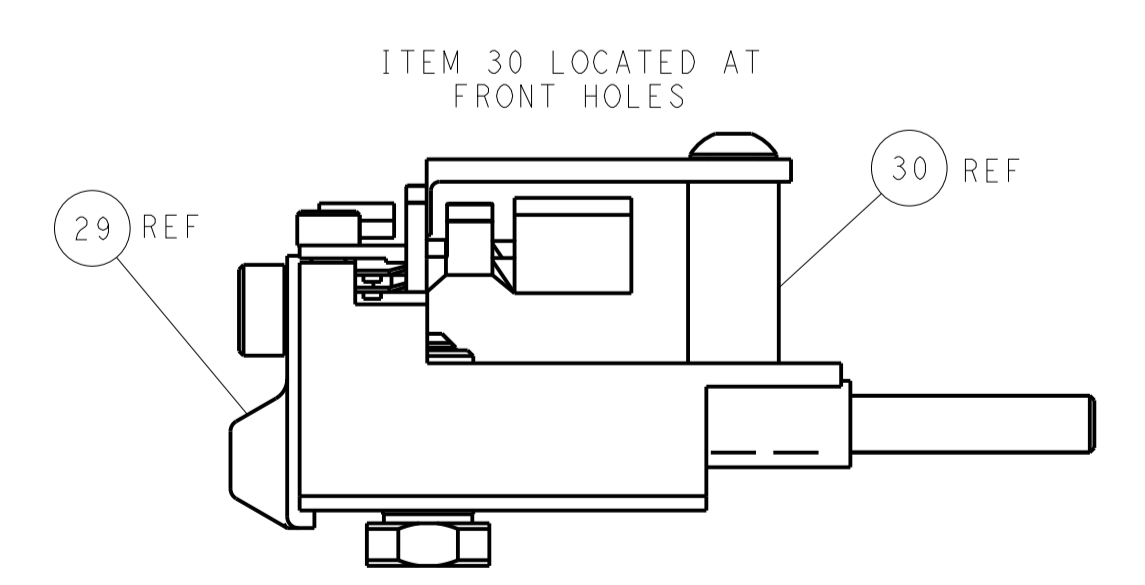

FEED TRACK POSITION
GUIDE BY INSULATION BARREL

PACIFIC VERSION
 Shown on sheets 3 of 4 & 4 of 4
 (Atlantic version shown on sheets 1 of 4 & 2 of 4)

DIMENSIONS:		TOLERANCES UNLESS OTHERWISE SPECIFIED:		DWG: HOFFNER 18AUG2011		TE Connectivity	
mm	0 PLC ±	1 PLC ±	2 PLC ±	3 PLC ±	4 PLC ±	Harrisburg, PA 17105-3608	
MATERIAL:		FINISH:		REV: T. ELBIN 19AUG2011		NAME: Ocean Side Feed Applicator	
				PRODUCT SPEC:		SIZE: CAGE CODE: DRAWING NO:	
				APPLICATION SPEC:		RESTRICTED TO:	
				WEIGHT:		SCALE: 1:2 SHEET 4 OF 4 REV: P1	
				CUSTOMER ACCESSIBLE PRODUCTION DRAWING		A1 00779 ©=2151151	

Mouser Electronics

Authorized Distributor

Click to View Pricing, Inventory, Delivery & Lifecycle Information:

[TE Connectivity:](#)

[2-2151151-2](#)