

PART NUMBER	REVISION	DESCRIPTION	FEED TYPE
2150312-1	C	FINE CRIMP HEIGHT ADJUST	MECHANICAL
2150312-2	D	FINE CRIMP HEIGHT ADJUST	PNEUMATIC
7-2150312-1	C	MECHANICAL AND CRIMP TOOLING KIT	MECHANICAL
7-2150312-2	D	PNEUMATIC AND CRIMP TOOLING KIT	PNEUMATIC
7-2150312-7	A	CRIMP TOOLING KIT	-

ATLANTIC VERSION TERMINATOR INTERFACE ADAPTER

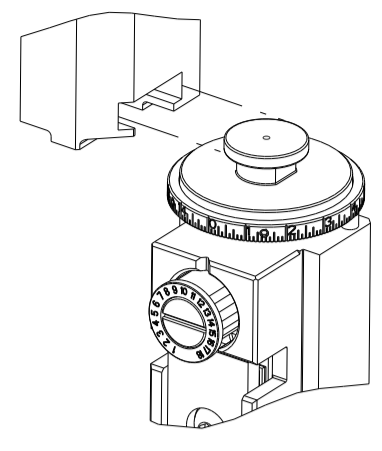

APPLICATOR DATA		
CRIMP	SIZE	TYPE
WIRE	2.79 mm [.110]	F
INSUL	6.35 mm [.250]	F

APPLICATOR INSTRUCTIONS 408-35043

TERMINAL DATA: TE TERMINAL		TE CRIMP SPECIFICATION	
TERMINAL NAME: RECEPTACLE, FASTON, .187 SERIES			
WIRE STRIP LENGTH		INSULATION DIAMETER RANGE	
5.21-5.97 mm [.205-.235 IN]		∅4.57-5.84 mm [.180-.230 IN]	
TERMINAL APPLICATION SPECIFICATION	114-2036		
TERMINALS APPLIED			
TE TERMINAL	TE TERMINAL	TE TERMINAL	TE TERMINAL
63596-1	63596-2	60742-1	60742-2
63832-2			

WIRE SIZE	CRIMP HEIGHT mm [INCH]	CRIMP HEIGHT REFERENCE SETTING
2x AWG 16	1.96+/-0.05 [.077+/-0.002]	3.4
14 AWG	1.80+/-0.05 [.071+/-0.002]	5.3
16 AWG	1.58+/-0.05 [.062+/-0.002]	7.6
18 AWG	1.42+/-0.05 [.056+/-0.002]	9.2

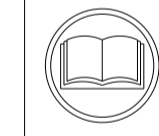

- 1 RECOMMENDED SPARE PARTS
- 2 REFER TO SUPPLIED INSTRUCTION SHEET FOR CLEANING, LUBRICATION AND STORAGE OF APPLICATOR.
- 3 APPLY PART NUMBER 2-23419-6 LOCTITE TO THREADS OF ITEM 242.
- 4 CRIMP HEIGHT REFERENCE SETTING WAS THE SETTING USED WHEN THE APPLICATOR WAS QUALIFIED AT THE FACTORY. ADJUSTMENT MAY BE NECESSARY WHEN RUNNING APPLICATOR IN THE FIELD.
- 5. UNLESS SPECIFIED OTHERWISE TORQUE VALUES SHALL BE USED PER DOCUMENT, 101-35000.

**\*WARNING**  
 ON INSTALLATION, SET WIRE DISC TO CRIMP HEIGHT REFERENCE SETTING FOR LARGEST WIRE SIZE. CRIMP HEIGHT REFERENCE SETTINGS GREATER THAN THE VALUE SHOWN MAY CAUSE DAMAGE TO THE CRIMP TOOLING. REFER TO THE INSTRUCTION SHEET FOR PROPER SETUP AND ADJUSTMENTS.

ATLANTIC VERSION  
 Shown on sheets 1 of 4 & 2 of 4  
 (Pacific version shown on sheets 3 of 4 & 4 of 4)

LOC	DIST	REVISIONS					
A	66	P	LTN	DESCRIPTION	DATE	OWN	APVD
		A		RELEASED	08MAR2013	LG	GB
		B		ECR-13-009443	09JUN2013	KH	GB
		C		ECR-18-015901	08OCT2018	TB	TE
		D		ECR-21-005972	02JUN2021	FZ	TE

-	1	-	1	-	2119641-1	FEED CAM, AIR FEED	248	
-	1	1	1	1	2119082-9	CAM, SNAIL, INSULATION ADJUSTMENT	244	
-	1	1	1	1	2079764-1	WASHER, WAVE SPRING, CREST-TO-CREST	243	
3	-	1	1	1	2119083-1	RETAINER, INSULATION DIAL	242	
-	-	1	-	1	2119580-1	MECHANICAL FEED ASSEMBLY	239	
-	1	-	1	-	2844940-3	AIR FEED MODULE	238	
-	1	1	1	1	1-18028-0	WASHER, FLAT, REG M8	192	
-	REF	REF	REF	REF	994970-2	COUNTER, MAGNETIC	164	
-	1	1	1	1	455888-4	SPACER, CRIMPER	82	
-	1	1	1	1	2119791-9	DEPRESSOR, WIRE	73	
-	1	1	1	1	1803607-4	DOCUMENTATION PACKAGE	71	
-	2	2	2	2	2-18032-2	SCR, SET, FLT PNT, M3 X 10.0	70	
-	1	1	1	1	2119740-1	TAG, IDENTIFICATION	67	
-	2	2	2	2	2168078-1	SCREW, DRIVE, RH, RoHS, 2 x .188	66	
-	2	2	2	2	2168400-8	SHCS, LOW HEAD, RoHS, M4 X 16	64	
-	1	1	1	1	2168083-2	SCR, SKT HD CAP, RoHS, M4 X 8.0	60	
-	1	1	1	1	5-18022-5	SCR, HEX HD CAP, M4 X 6.0	59	
-	-	1	-	1	2063961-1	FEED FINGER	58	
-	3	3	3	3	2168400-4	SHCS, LOW HEAD, RoHS, M4 X 8	57	
-	2	2	2	2	2168083-2	SCR, SKT HD CAP, RoHS, M4 X 8.0	56	
-	2	2	2	2	5018030-1	NUT, HEX, REG, RoHS, M3	54	
-	2	2	2	2	986965-8	NUT, LOCK, HEX, TORQUE (M4)	53	
-	1	-	1	-	2063961-1	FEED FINGER	51	
-	1	2	1	2	18023-9	SCR, SKT HD CAP M4 X 6.0	49	
-	-	1	-	1	2119652-1	FEED CAM, PRE FEED	48	
-	-	1	-	1	2119653-1	FEED CAM, POST FEED	47	
-	1	1	1	1	2119655-5	APPLICATOR BASIC ASSEMBLY, EF	46	
-	1	1	1	1	1803517-1	RAM ASSEMBLY, EF ATLANTIC	44	
-	1	1	1	1	1803602-1	SCR, BHSC, RoHS (M8 X 25)	41	
-	7	7	7	7	1-18028-2	WASHER, FLAT, REG M4	33	
-	2	2	2	2	2168083-9	SCR, SKT HD CAP, RoHS, M4 X 20	31	
-	2	2	2	2	2168083-2	SCR, SKT HD CAP, RoHS, M4 X 8.0	29	
-	1	1	1	1	240639-1	STRIPPER (MACHINING)	27	
-	2	2	2	2	1-2168083-5	SCR, SKT HD CAP, RoHS, M4 X 30	25	
-	1	1	1	1	1752371-5	PLATE, STRIP GUIDE	24	
-	1	1	1	1	240825-3	PLATE, STRIP HOLD DOWN	23	
-	2	2	2	2	2-22281-3	SPRING, COMPRESSION	22	
-	1	1	1	1	1803292-4	DRAG	20	
-	2	2	2	2	1901259-5	GUIDE, LOWER STRIP	18	
-	4	4	4	4	1-2079383-1	SCR, BHSC, RoHS (M6 X 12)	17	
-	1	1	1	1	240644-9	PLATE, REAR SHEAR	11	
-	-	-	-	-	-	-	10	
-	1	1	1	1	5-690482-7	PLATE, FRONT SHEAR	9	
1	2	2	1	1	1803074-2	ANVIL, COMBINATION, END FEED	8	
1	1	1	1	1	2217206-5	BLADE, SLUG	7	
-	-	-	-	-	-	-	6	
-	1	1	1	1	5-240641-2	SPACER	5	
-	1	1	1	1	238011-1	BLOCK, CRIMPER SPACER	4	
1	2	2	1	1	2-1803019-2	CRIMPER, INSULATION O	3	
-	-	-	-	-	-	-	2	
1	2	2	1	1	456408-3	CRIMPER, WIRE PREMIUM	1	
-	77	72	71	2	-1	PART NO	DESCRIPTION	ITEM NO

DIMENSIONS:		TOLERANCES UNLESS OTHERWISE SPECIFIED:		MATERIAL:		FINISH:	
mm	0 PLC ±	1 PLC ±	2 PLC ±	3 PLC ±	4 PLC ±	ANGLES ±	FINISH ±

OWN	H. HUANG	22JAN2013	CHK	S. XI	22JAN2013	APVD	S. XI	22JAN2013	NAME	TE Connectivity	Harrisburg, PA 17105-3608
Ocean End Feed Applicator											
SIZE	CAGE CODE	DRAWING NO	RESTRICTED TO								
A1	00779	2150312	-								
Customer Accessible Production Drawing											
										SCALE	1:1
										SHEET	1 of 4
										REV	D

LOC	DIST	REVISIONS					
A	66	P	LTM	DESCRIPTION	DATE	OWN	APVD
		-		SEE SHEET 1			

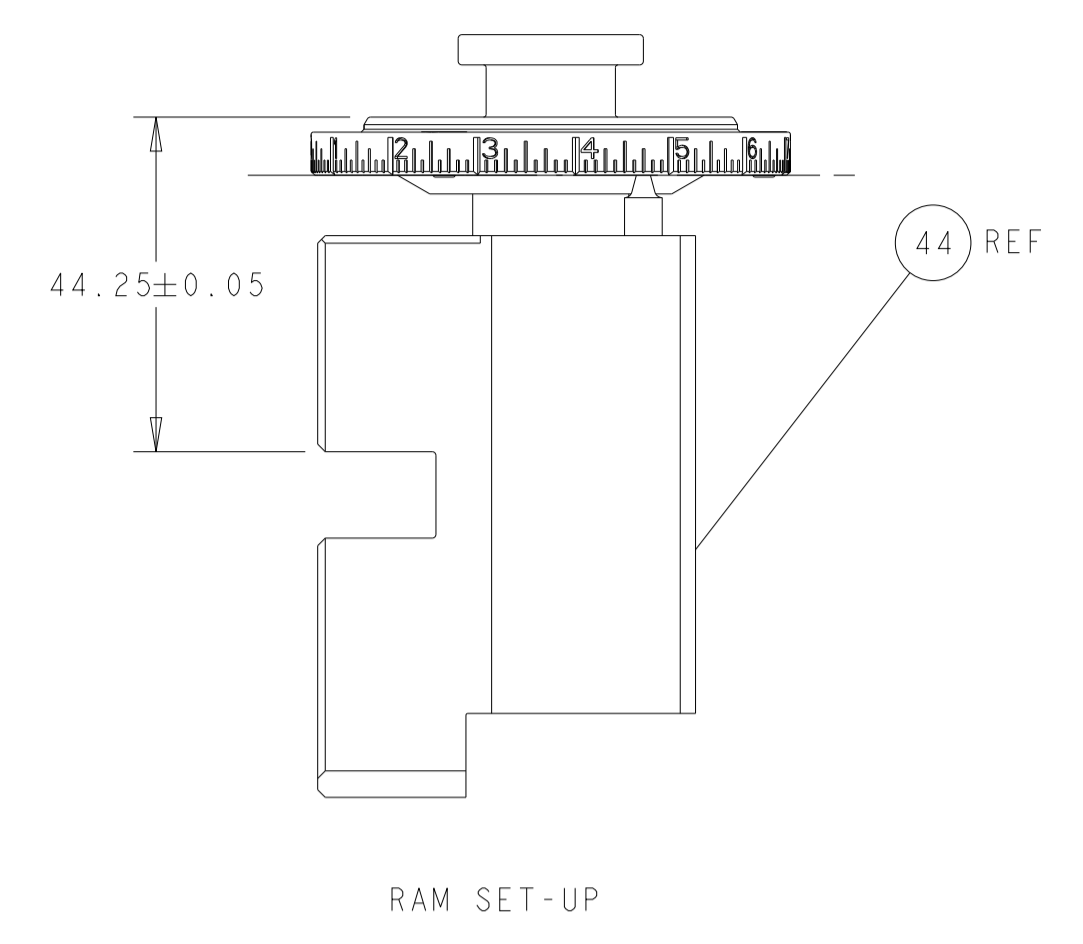

# FEED TYPE MECHANICAL

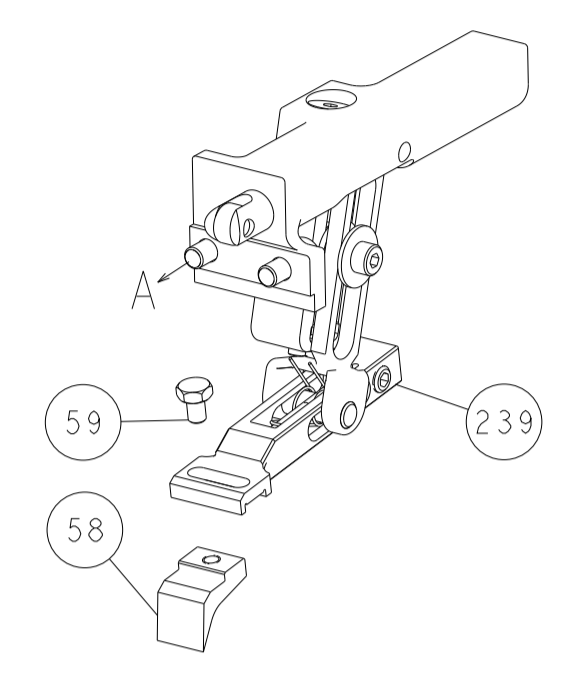

# PNEUMATIC

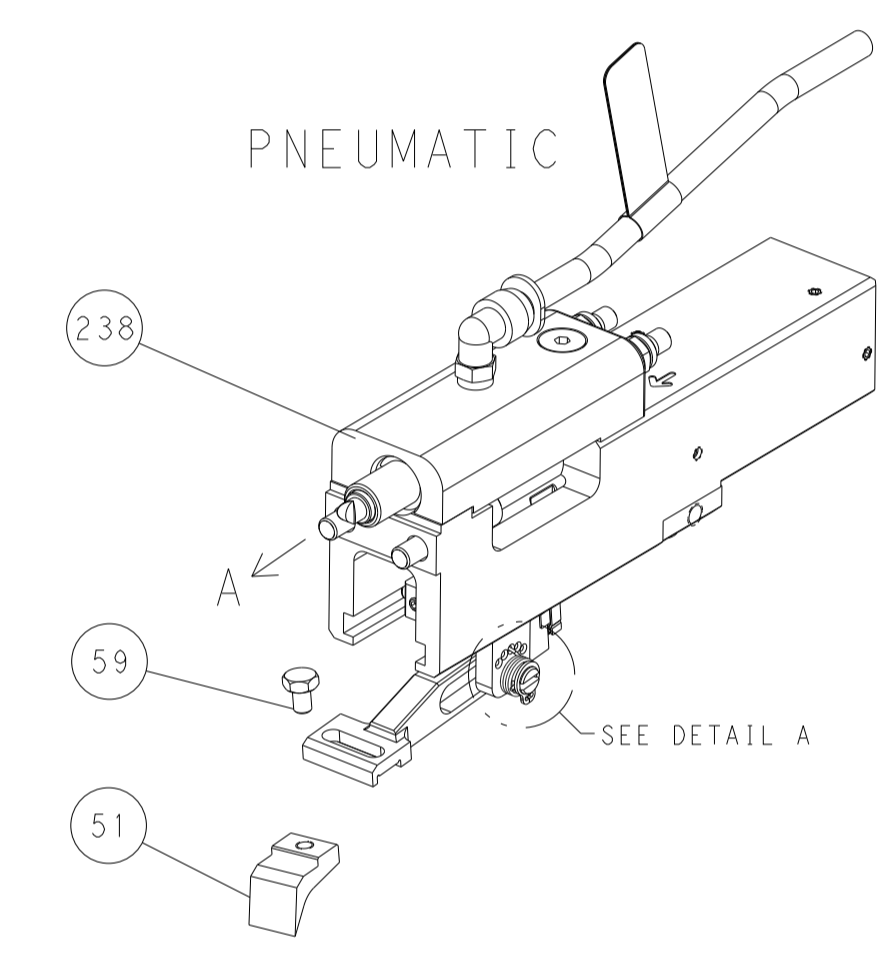

# FEED SPRING SETTING POSITION

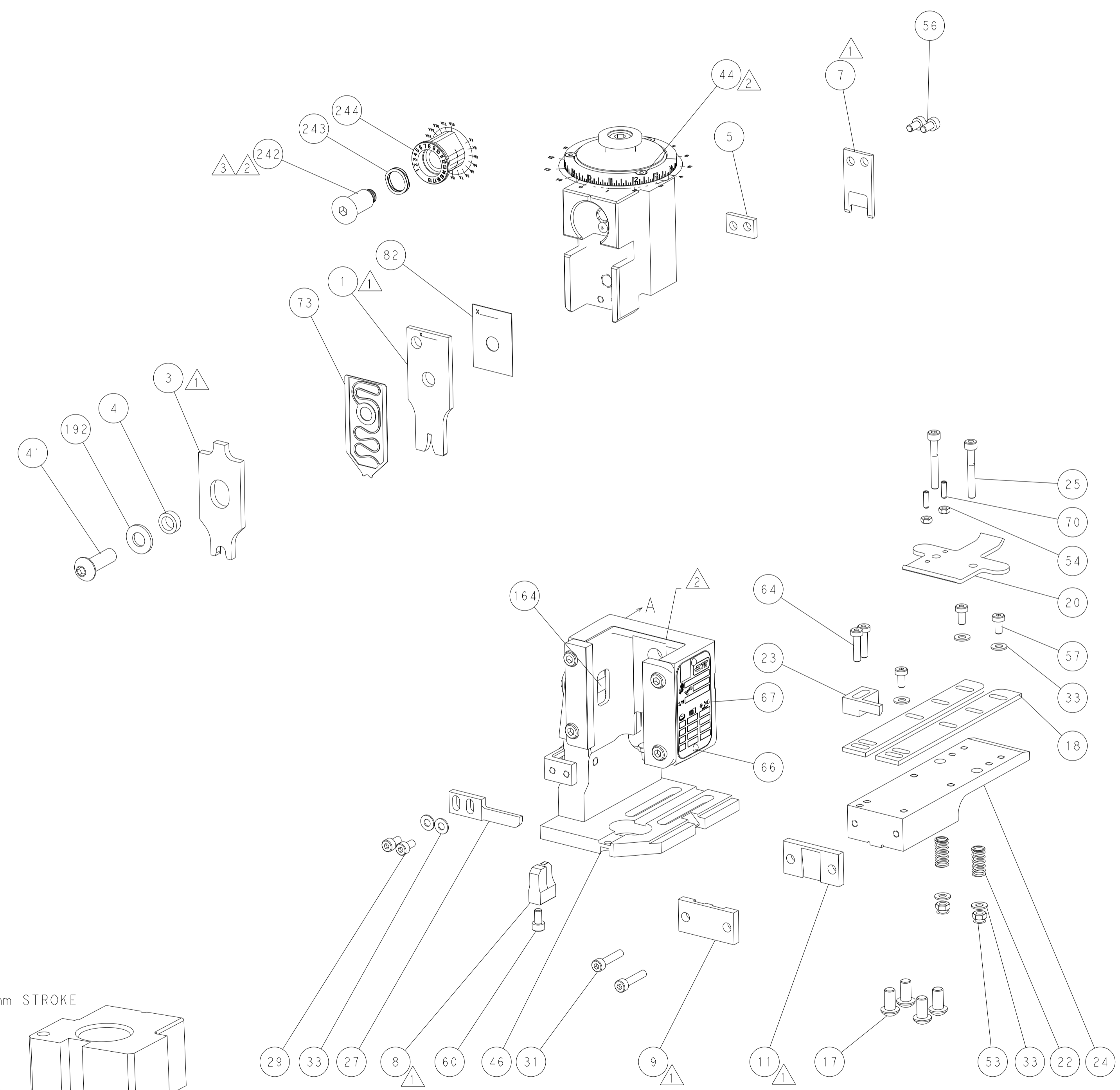
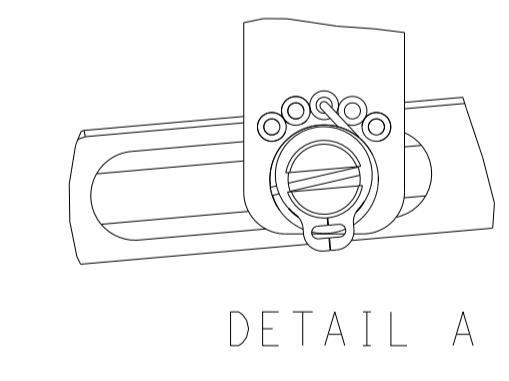

# CAM POSITIONS

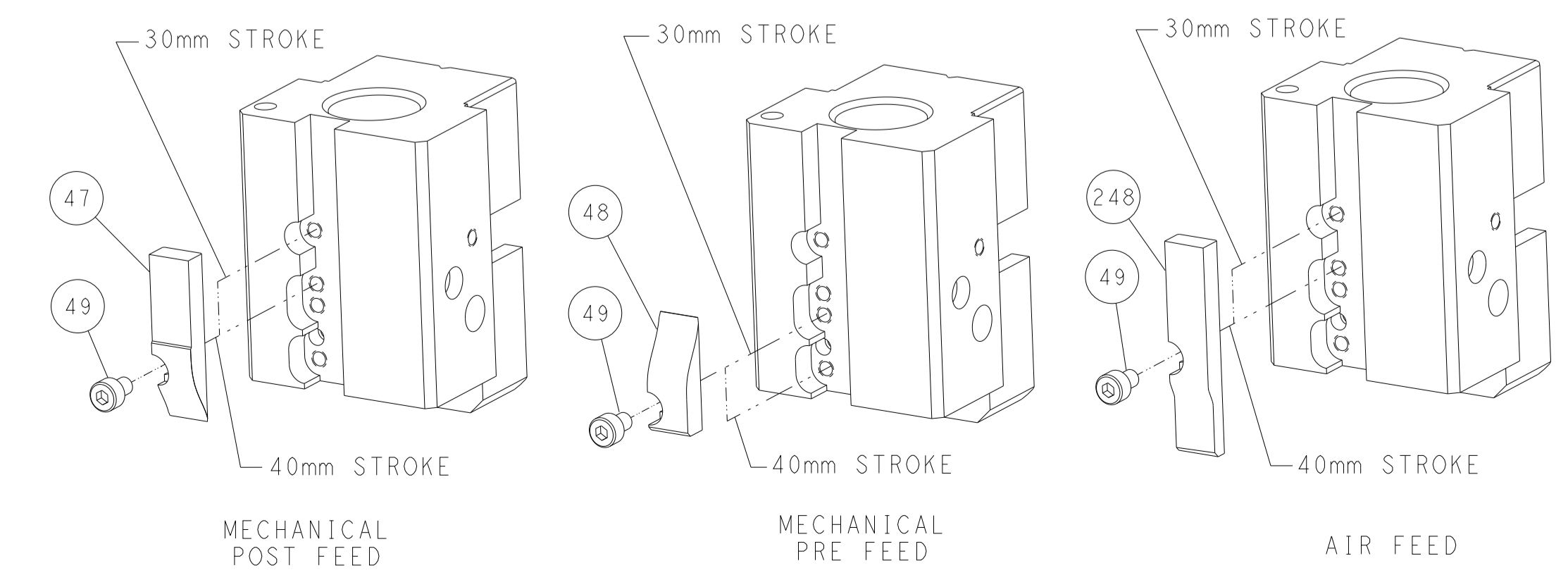

**ATLANTIC VERSION**  
 Shown on sheets 1 of 4 & 2 of 4  
 (Pacific version shown on sheets 3 of 4 & 4 of 4)

<small>THIS DRAWING IS UNPUBLISHED. RELEASED FOR PUBLICATION BY TYCO ELECTRONICS CORPORATION. ALL RIGHTS RESERVED.</small>		DWN: K. HUANG CHK: S. XI APVD: S. XI DATE: 22JAN2013	NAME: Ocean End Feed Applicator SIZE: A1 CAGE CODE: 00779 DRAWING NO: 2150312 SCALE: 1:1	TE Connectivity Harrisburg, PA 17105-3608
DIMENSIONS: mm TOLERANCES UNLESS OTHERWISE SPECIFIED: 0 PLC ±. 1 PLC ±. 2 PLC ±. 3 PLC ±. 4 PLC ±. ANGLES ±. FINISH	WEIGHT: - RESTRICTED TO: -	SHEET 2 OF 4 REV D	Customer Accessible Production Drawing	

PART NUMBER	REVISION	DESCRIPTION	FEED TYPE
2-2150312-1	C	FINE CRIMP HEIGHT ADJUST	MECHANICAL
2-2150312-2	D	FINE CRIMP HEIGHT ADJUST	PNEUMATIC
7-2150312-7	A	CRIMP TOOLING KIT	-

PACIFIC VERSION TERMINATOR  
 INTERFACE ADAPTER

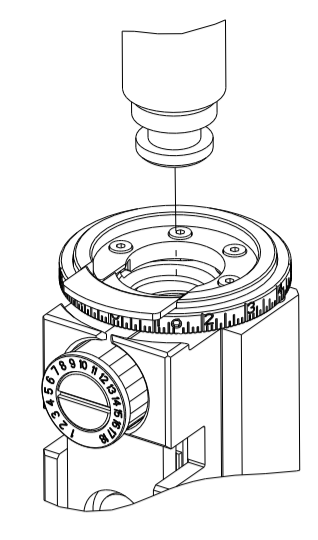

APPLICATOR DATA		
CRIMP	SIZE	TYPE
WIRE	2.79 mm (.110)	F
INSUL	6.35 mm (.250)	F
APPLICATOR INSTRUCTIONS 408-35043		

TERMINAL DATA: TE TERMINAL TE CRIMP SPECIFICATION			
TERMINAL NAME: RECEPTACLE, FASTON, .187 SERIES			
WIRE STRIP LENGTH		INSULATION DIAMETER RANGE	
5.21-5.97 mm (.205-.235 IN)		4.57-5.84 mm (.180-.230 IN)	
TERMINAL APPLICATION SPECIFICATION	114-2036	-	-
TERMINALS APPLIED			
TE TERMINAL	TE TERMINAL	TE TERMINAL	TE TERMINAL
63596-1	63596-2	60742-1	60742-2
63832-2			

WIRE SIZE	CRIMP HEIGHT mm [INCH]	CRIMP HEIGHT REFERENCE SETTING
2x AWG 16	1.96+/-0.05 [.077+/-0.002]	3.4
14 AWG	1.80+/-0.05 [.071+/-0.002]	5.3
16 AWG	1.58+/-0.05 [.062+/-0.002]	7.6
18 AWG	1.42+/-0.05 [.056+/-0.002]	9.2



- RECOMMENDED SPARE PARTS
- REFER TO SUPPLIED INSTRUCTION SHEET FOR CLEANING, LUBRICATION AND STORAGE OF APPLICATOR.
- APPLY PART NUMBER 2-23419-6 LOCTITE TO THREADS OF ITEM 242.
- CRIMP HEIGHT REFERENCE SETTING WAS THE SETTING USED WHEN THE APPLICATOR WAS QUALIFIED AT THE FACTORY. ADJUSTMENT MAY BE NECESSARY WHEN RUNNING APPLICATOR IN THE FIELD.
- UNLESS SPECIFIED OTHERWISE TORQUE VALUES SHALL BE USED PER DOCUMENT, 101-35000.

**\*WARNING**  
 ON INSTALLATION, SET WIRE DISC TO CRIMP HEIGHT REFERENCE SETTING FOR LARGEST WIRE SIZE. CRIMP HEIGHT REFERENCE SETTINGS GREATER THAN THE VALUE SHOWN MAY CAUSE DAMAGE TO THE CRIMP TOOLING. REFER TO THE INSTRUCTION SHEET FOR PROPER SETUP AND ADJUSTMENTS.

**PACIFIC VERSION**  
 Shown on sheets 3 of 4 & 4 of 4  
 (Atlantic version shown on sheets 1 of 4 & 2 of 4)

LOC	DIST	REVISIONS					
A	66	P	LTN	DESCRIPTION	DATE	OWN	APVD
-	-	-	-	SEE SHEET 1	-	-	-

-	1	1	2119082-9	CAM, SNAIL, INSULATION ADJUSTMENT	244	
-	1	1	2079764-1	WASHER, WAVE SPRING, CREST-TO-CREST	243	
-	1	1	2119083-1	RETAINER, INSULATION DIAL	242	
-	-	1	2119580-1	MECHANICAL FEED ASSEMBLY	239	
-	1	-	2844940-3	AIR FEED MODULE	238	
-	1	1	1-18028-0	WASHER, FLAT, REG M8	192	
-	4	4	2079383-9	SCR, BHSC, RoHS (M6 X 20)	186	
-	REF	REF	994970-2	COUNTER, MAGNETIC	164	
-	1	-	2119641-2	FEED CAM, AIR FEED	152	
-	1	1	2168083-8	SCR, SKT HD CAP, RoHS, M4 X 16	144	
-	-	1	2119653-2	FEED CAM, POST FEED	142	
-	1	1	2119655-6	APPLICATOR BASIC ASSEMBLY, EF	141	
-	1	1	1803518-1	RAM ASSEMBLY, EF PACIFIC	140	
-	1	1	455888-4	SPACER, CRIMPER	82	
-	1	1	2119791-9	DEPRESSOR, WIRE	73	
-	1	1	1803607-4	DOCUMENTATION PACKAGE	71	
-	2	2	2-18032-2	SCR, SET, FLT PNT, M3 X 10.0	70	
-	1	1	2119740-1	TAG, IDENTIFICATION	67	
-	2	2	2168078-1	SCREW, DRIVE, RH, RoHS, 2 x .188	66	
-	2	2	2168400-8	SHCS, LOW HEAD, RoHS, M4 X 16	64	
-	1	1	5-18022-5	SCR, HEX HD CAP, M4 X 6.0	59	
-	-	1	2063961-1	FEED FINGER	58	
-	3	3	2168400-4	SHCS, LOW HEAD, RoHS, M4 X 8	57	
-	2	2	2168083-2	SCR, SKT HD CAP, RoHS, M4 X 8.0	56	
-	2	2	5018030-1	NUT, HEX, REG, RoHS, M3	54	
-	2	2	986965-8	NUT, LOCK, HEX, TORQUE (M4)	53	
-	1	-	2063961-1	FEED FINGER	51	
-	1	2	18023-9	SCR, SKT HD CAP M4 X 6.0	49	
-	-	1	2119652-1	FEED CAM, PRE FEED	48	
-	1	1	1803602-1	SCR, BHSC, RoHS (M8 X 25)	41	
-	7	7	1-18028-2	WASHER, FLAT, REG M4	33	
-	2	2	2168083-9	SCR, SKT HD CAP, RoHS, M4 X 20	31	
-	2	2	2168083-2	SCR, SKT HD CAP, RoHS, M4 X 8.0	29	
-	1	1	240639-1	STRIPPER (MACHINING)	27	
-	2	2	1-2168083-5	SCR, SKT HD CAP, RoHS, M4 X 30	25	
-	1	1	1752371-5	PLATE, STRIP GUIDE	24	
-	1	1	240825-3	PLATE, STRIP HOLD DOWN	23	
-	2	2	2-22281-3	SPRING, COMPRESSION	22	
-	1	1	1803292-4	DRAG	20	
-	2	2	1901259-5	GUIDE, LOWER STRIP	18	
-	1	1	240644-9	PLATE, REAR SHEAR	11	
-	-	-	-	-	10	
-	1	1	5-690482-7	PLATE, FRONT SHEAR	9	
-	1	1	1803074-2	ANVIL, COMBINATION, END FEED	8	
-	1	1	2217206-5	BLADE, SLUG	7	
-	-	-	-	-	6	
-	1	1	5-240641-2	SPACER	5	
-	1	1	238011-1	BLOCK, CRIMPER SPACER	4	
-	1	1	2-1803019-2	CRIMPER, INSULATION O	3	
-	-	-	-	-	2	
-	1	1	456408-3	CRIMPER, WIRE PREMIUM	1	
-	77	22	21	PART NO	DESCRIPTION	ITEM NO

DIMENSIONS:		TOLERANCES UNLESS OTHERWISE SPECIFIED:		DRAWING NO	
mm	0 PLC ±	1 PLC ±	2 PLC ±	3 PLC ±	4 PLC ±
	ANGLES	FINISH			
MATERIAL					
Customer Accessible Production Drawing				SCALE	1:1
SHEET				3	OF 4
REV				D	

LOC		DIST		REVISIONS			
A	66	P	LTM	DESCRIPTION	DATE	DWN	APVD
		-		SEE SHEET 1			

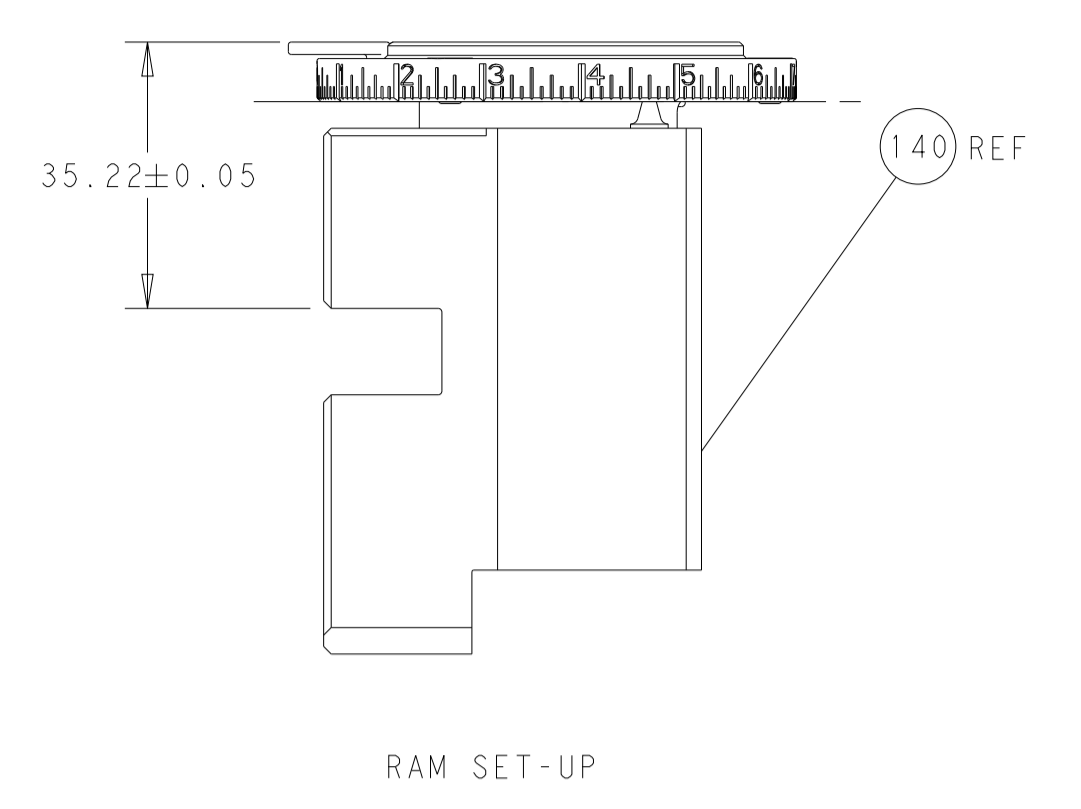

# FEED TYPE MECHANICAL

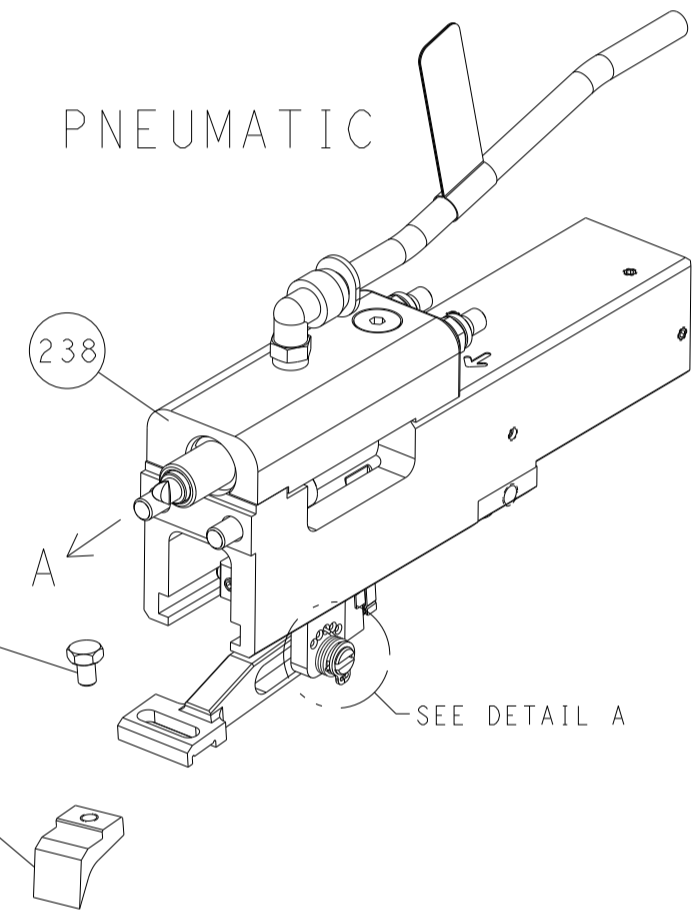
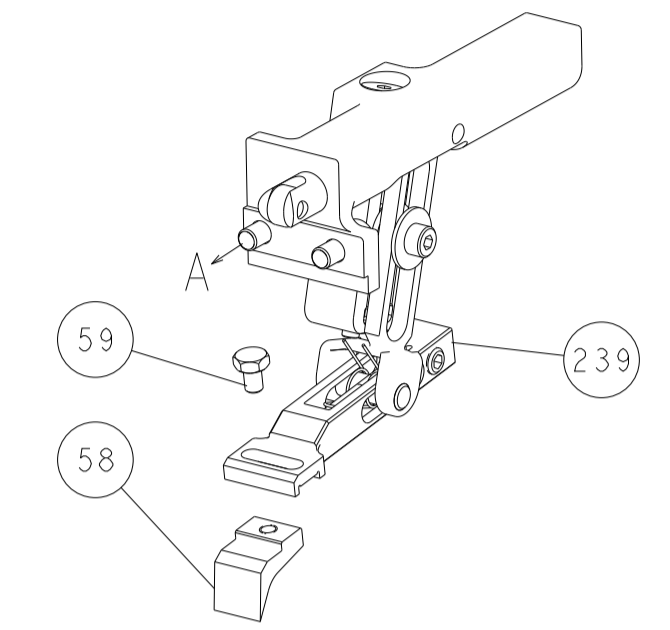

# FEED SPRING SETTING POSITION

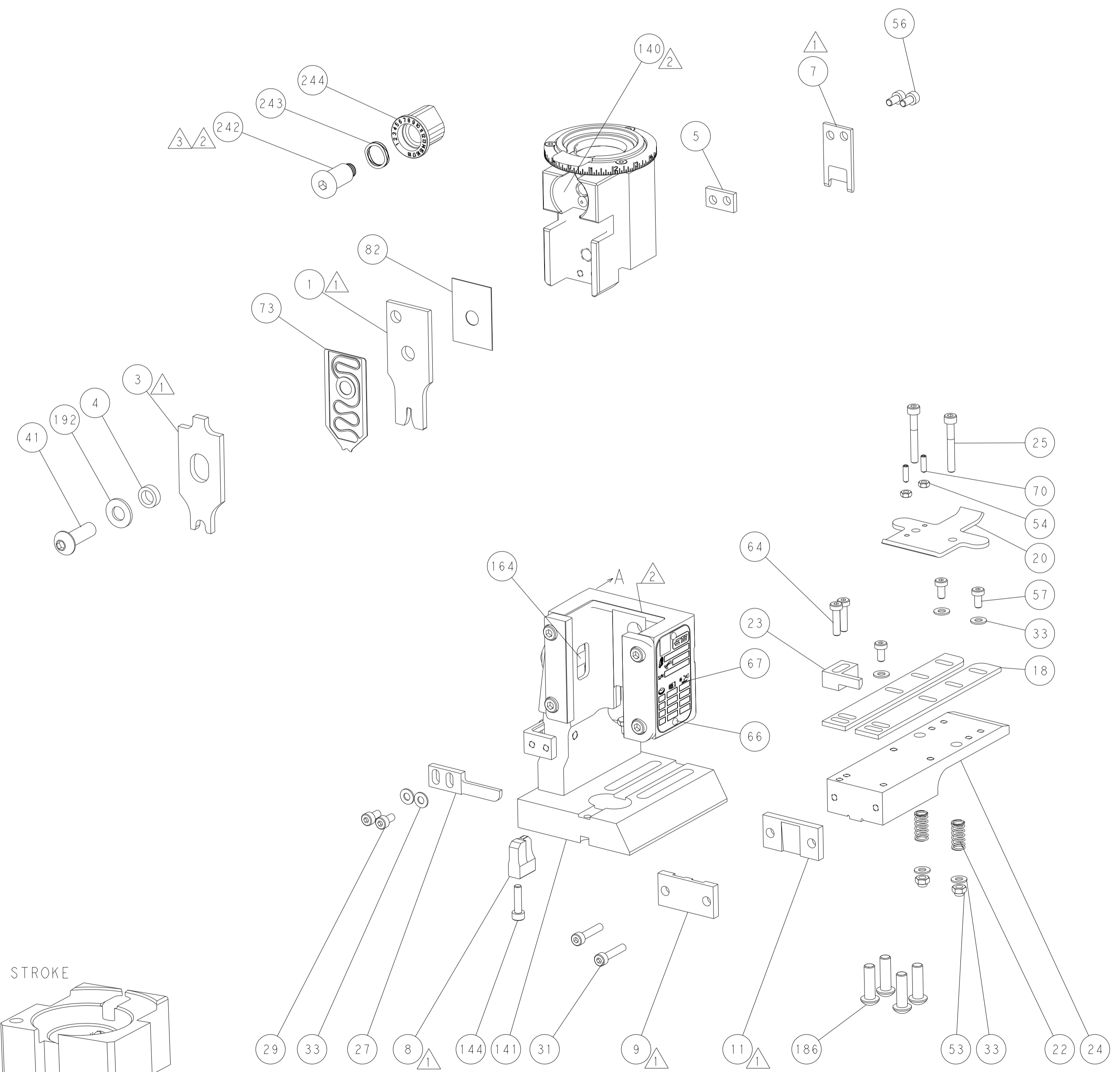
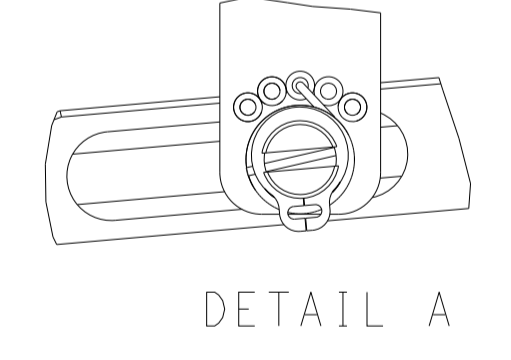

# CAM POSITIONS

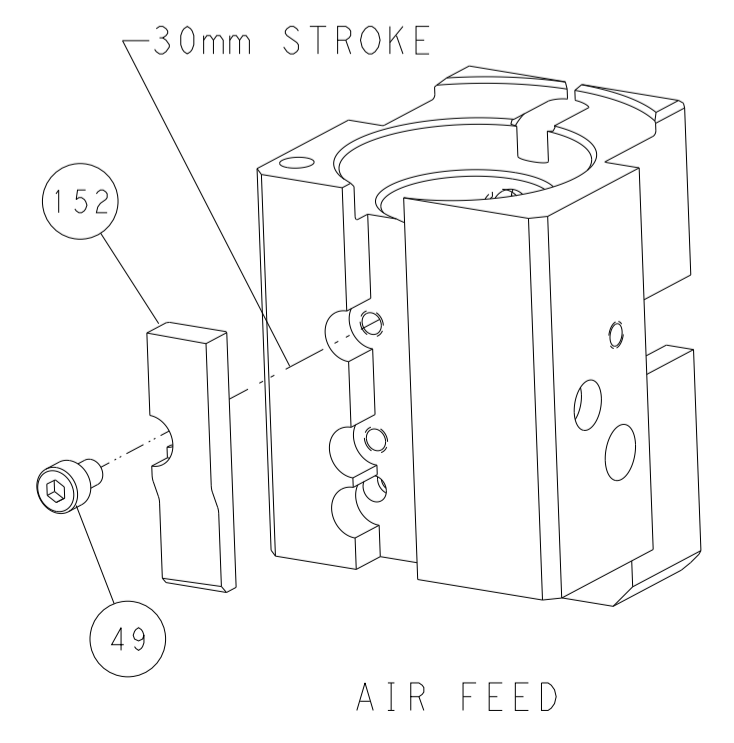
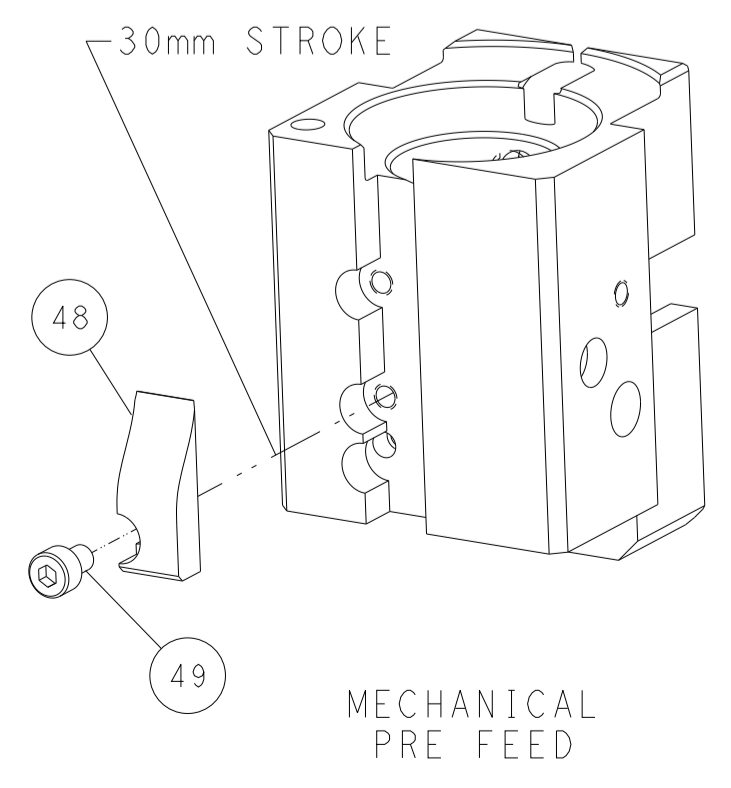
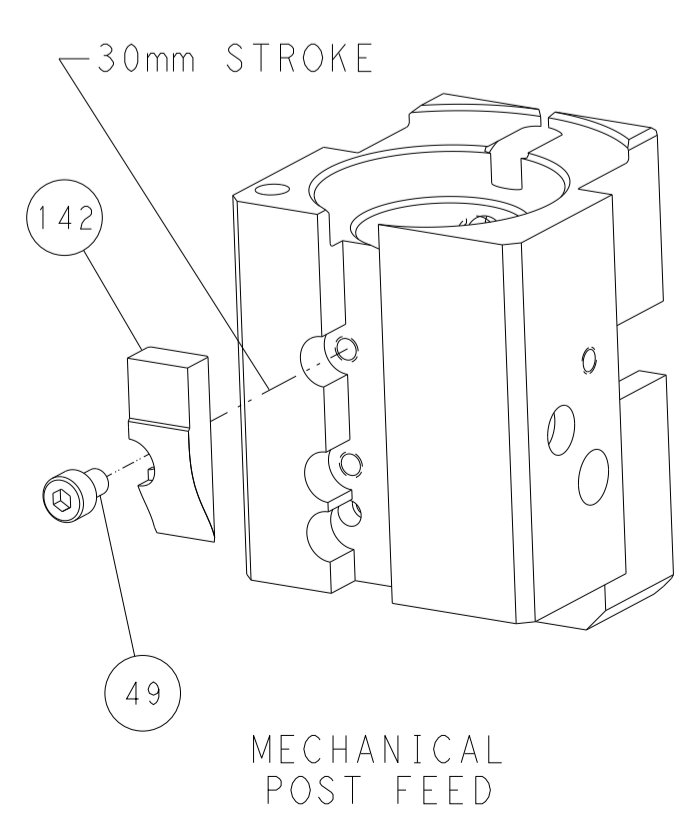

**PACIFIC VERSION**  
 Shown on sheets 3 of 4 & 4 of 4  
 (Atlantic version shown on sheets 1 of 4 & 2 of 4)

<small>THIS DRAWING IS UNPUBLISHED. RELEASED FOR PUBLICATION BY TYCO ELECTRONICS CORPORATION. ALL RIGHTS RESERVED.</small>		DWN: K. HUANG CHK: S. XI APVD: S. XI DATE: 22JAN2013	NAME: Ocean End Feed Applicator SIZE: A1 CAGE CODE: 00779 DRAWING NO: C=2150312 SCALE: 1:1 SHEET: 4 of 4 REV: D
DIMENSIONS: mm TOLERANCES UNLESS OTHERWISE SPECIFIED: 0 PLC ± 1 PLC ± 2 PLC ± 3 PLC ± 4 PLC ± ANGLES FINISH	TOLERANCES UNLESS OTHERWISE SPECIFIED: 0 PLC ± 1 PLC ± 2 PLC ± 3 PLC ± 4 PLC ± ANGLES FINISH	DATE: 22JAN2013 DATE: 22JAN2013 DATE: 22JAN2013 DATE: 22JAN2013 DATE: 22JAN2013 DATE: 22JAN2013	RESTRICTED TO:

# Mouser Electronics

Authorized Distributor

Click to View Pricing, Inventory, Delivery & Lifecycle Information:

[TE Connectivity:](#)

[2150312-2](#)