

THIS DRAWING IS UNPUBLISHED. RELEASED FOR PUBLICATION 20  
 © COPYRIGHT 20 BY - ALL RIGHTS RESERVED.

REVISIONS				
P	LTR	DESCRIPTION	DATE	APVD
A		INITIAL RELEASE	02JUN2015	DL CW
AI		ECR-18-004153	08AUG2018	GY CW
B		ECR-21-109004	13AUG2021	WQR CW

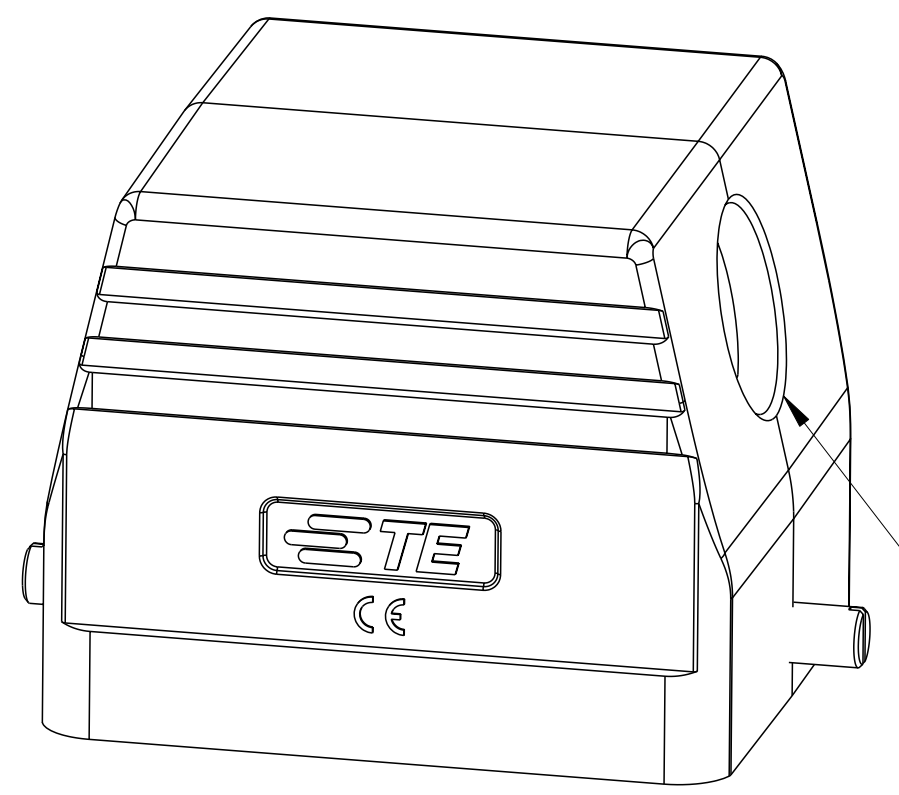

TYPE 1: SIDE ENTRY  
 类型1: 侧出

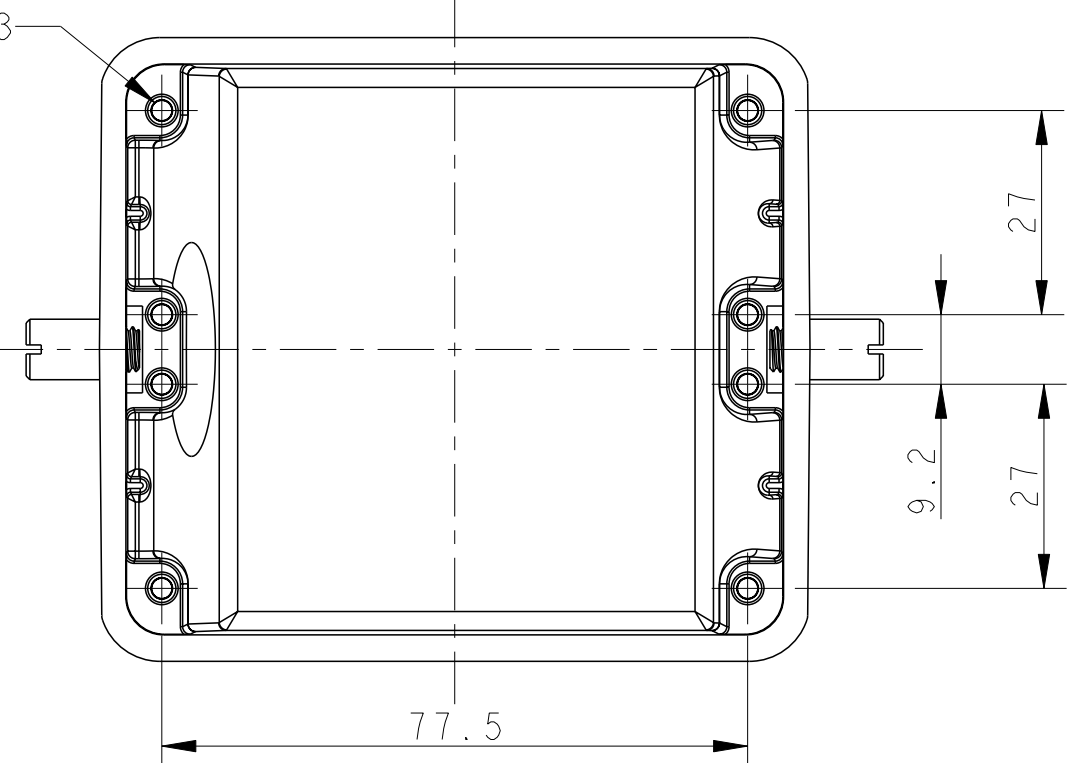
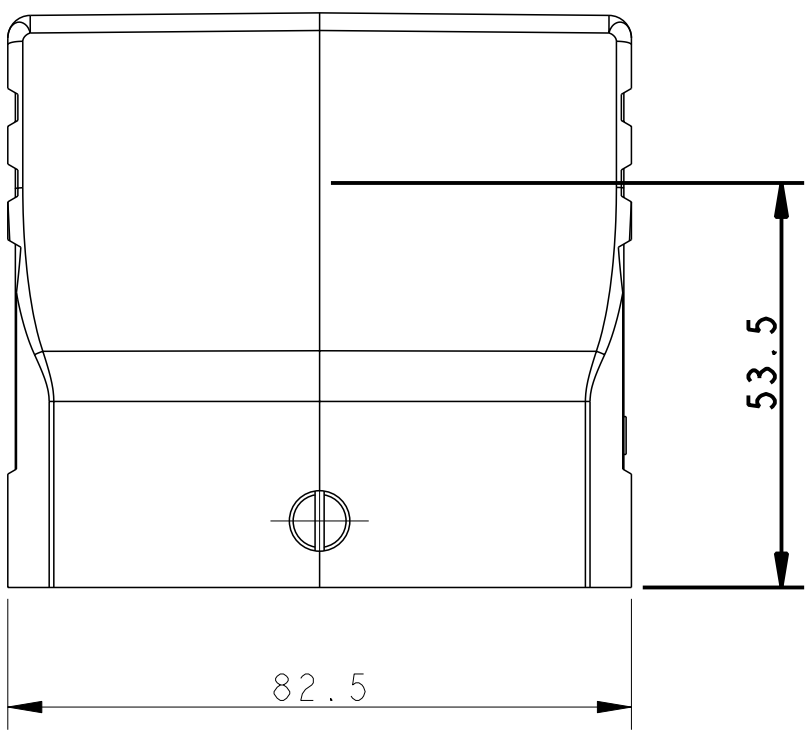
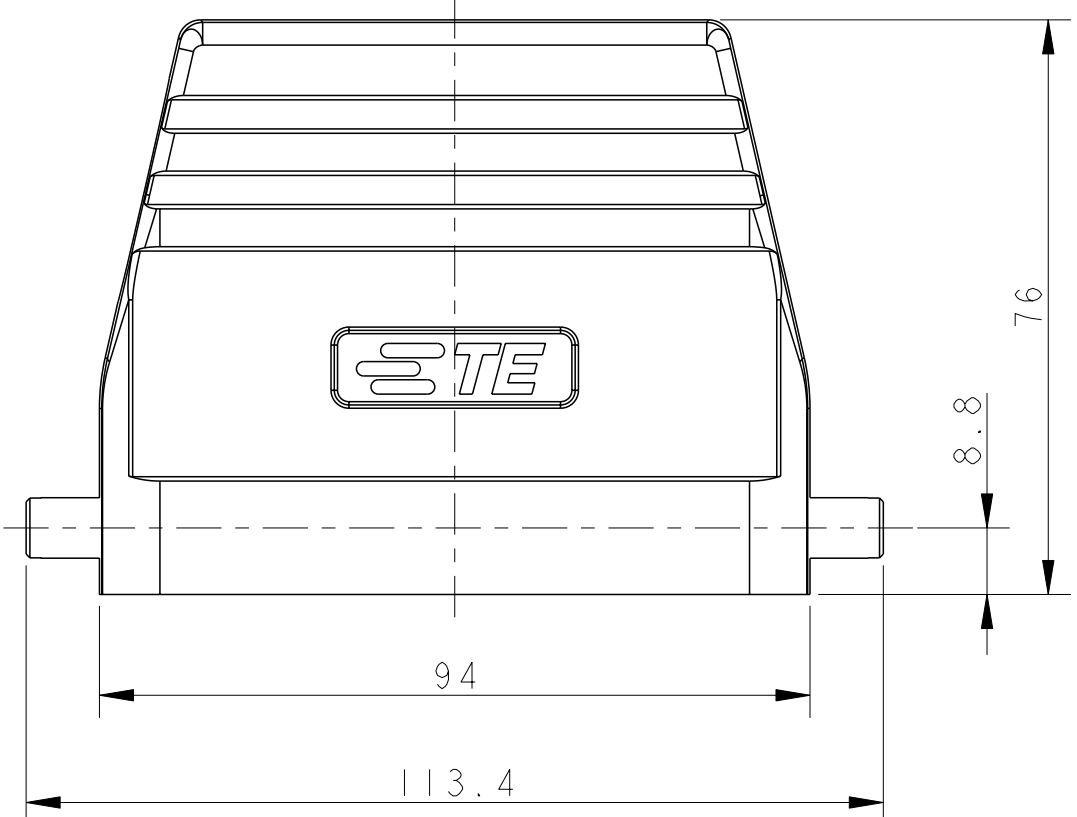
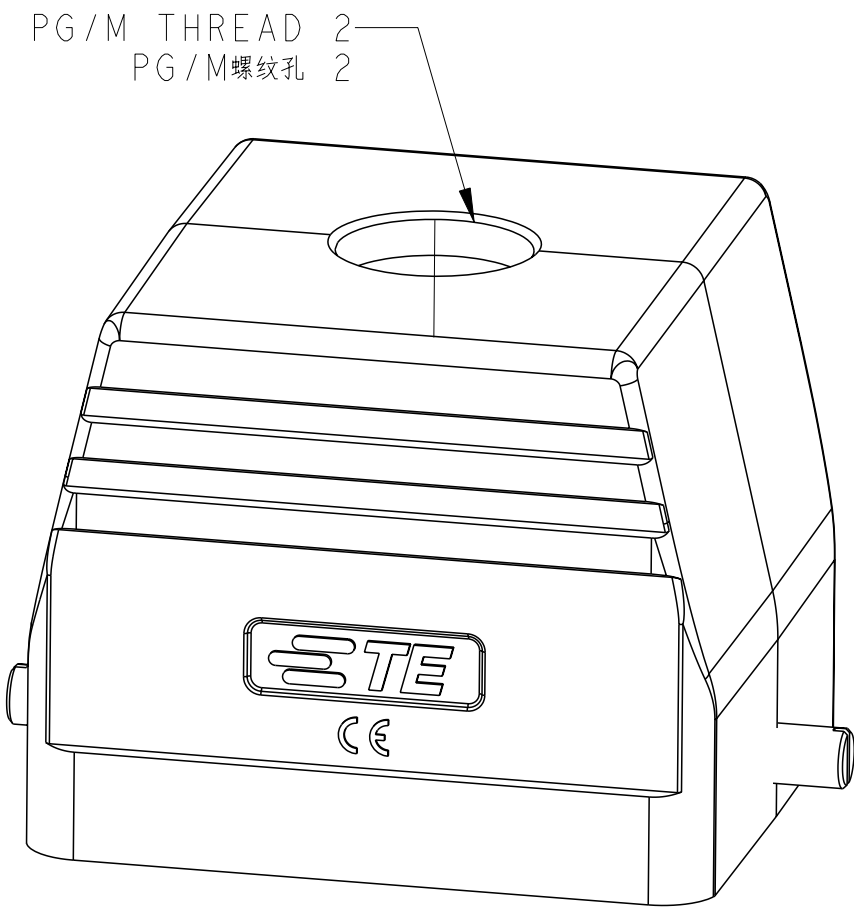

TYPE 2: TOP ENTRY, UNDEFINED DIMENSIONS REFER TO TYPE 1.  
 类型2: 顶出, 未定义尺寸及规格参照类型1。

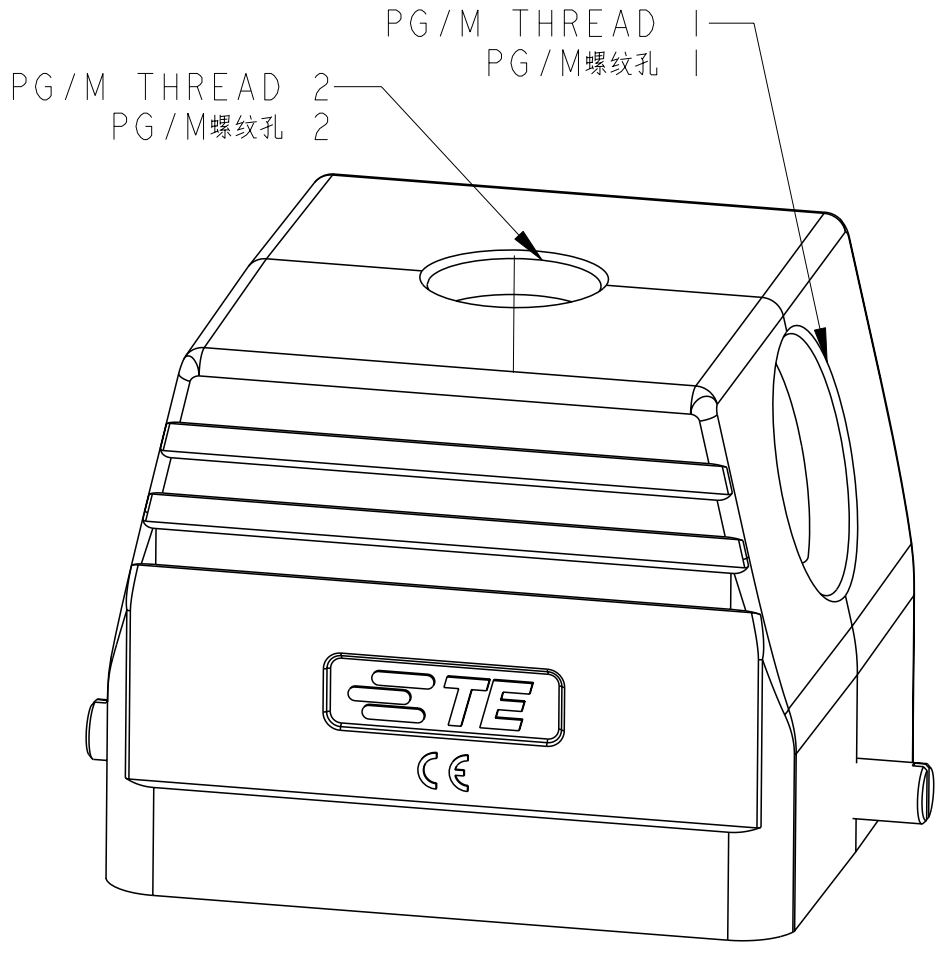

TYPE 3: SIDE/TOP ENTRY, UNDEFINED DIMENSIONS REFER TO TYPE 1.  
 类型3: 侧/顶出, 未定义尺寸及规格参照类型1。

PG/M THREAD 1  
 PG/M螺纹孔 1

NOTES:  
 1. TECHNICAL CHARACTERISTICS:  
 BODY MATERIAL: DIE CAST ALUMINIUM ALLOY  
 SURFACE TREATMENT: POWDER-COATED, GRAY  
 DEGREE OF PROTECTION: IP65 (MATED)

注释:  
 1. 技术参数:  
 主体材料: 铝合金  
 表面处理: 粉末喷涂, 灰色  
 防护等级: IP65(配合)

Printed on 20 Aug 2021 14:44 (China Standard Time) from IE343646

PART NUMBER 料号	PART DESCRIPTION 描述	PG/M THREAD 1 PG/M螺纹孔1	PG/M THREAD 2 PG/M螺纹孔2	TYPE 类型
T1310320121-000	H32B HOOD, SIDE ENTRY PG21, 2 EAR, POWDER COATED, GREY H32B上壳, 侧出PG21, 2耳, 灰色粉末喷涂	PG21	-	TYPE 1 类型1
T1310320129-000	H32B HOOD, SIDE ENTRY PG29, 2 EAR, POWDER COATED, GREY H32B上壳, 侧出PG29, 2耳, 灰色粉末喷涂	PG29	-	
T1310320132-000	H32B HOOD, SIDE ENTRY M32, 2 EAR, POWDER COATED, GREY H32B上壳, 侧出M32, 2耳, 灰色粉末喷涂	M32	-	
T1310320136-000	H32B HOOD, SIDE ENTRY PG36, 2 EAR, POWDER COATED, GREY H32B上壳, 侧出PG36, 2耳, 灰色粉末喷涂	PG36	-	
T1310320140-000	H32B HOOD, SIDE ENTRY M40, 2 EAR, POWDER COATED, GREY H32B上壳, 侧出M40, 2耳, 灰色粉末喷涂	M40	-	
T1320320121-000	H32B HOOD, TOP ENTRY PG21, 2 EAR, POWDER COATED, GREY H32B上壳, 顶出PG21, 2耳, 灰色粉末喷涂	-	PG21	TYPE 2 类型2
T1320320125-000	H32B HOOD, TOP ENTRY M25, 2 EAR, POWDER COATED, GREY H32B上壳, 顶出M25, 2耳, 灰色粉末喷涂	-	M25	
T1320320129-000	H32B HOOD, TOP ENTRY PG29, 2 EAR, POWDER COATED, GREY H32B上壳, 顶出PG29, 2耳, 灰色粉末喷涂	-	PG29	
T1320320132-000	H32B HOOD, TOP ENTRY M32, 2 EAR, POWDER COATED, GREY H32B上壳, 顶出M32, 2耳, 灰色粉末喷涂	-	M32	
T1320320136-000	H32B HOOD, TOP ENTRY PG36, 2 EAR, POWDER COATED, GREY H32B上壳, 顶出PG36, 2耳, 灰色粉末喷涂	-	PG36	
T1320320140-000	H32B HOOD, TOP ENTRY M40, 2 EAR, POWDER COATED, GREY H32B上壳, 顶出M40, 2耳, 灰色粉末喷涂	-	M40	
T1320320142-000	H32B HOOD, TOP ENTRY PG42, 2 EAR, POWDER COATED, GREY H32B上壳, 顶出PG42, 2耳, 灰色粉末喷涂	-	PG42	
T1320320150-000	H32B HOOD, TOP ENTRY M50, 2 EAR, POWDER COATED, GREY H32B上壳, 顶出M50, 2耳, 灰色粉末喷涂	-	M50	TYPE 3 类型3
T1320320163-000	H32B HOOD, TOP ENTRY M63, 2 EAR, POWDER COATED, GREY H32B上壳, 顶出M63, 2耳, 灰色粉末喷涂	-	M63	
T1320320225-000	H32B HOOD, SIDE/TOP ENTRY M25, 2 EAR, POWDER COATED, GREY H32B上壳, 侧顶出M25, 2耳, 灰色粉末喷涂	M25	M25	

THIS DRAWING IS A CONTROLLED DOCUMENT.		DWN DAVID LI 02JUN2015	TE Connectivity	
DIMENSIONS: mm		CHK CHRIS WANG 02JUN2015		
TOLERANCES UNLESS OTHERWISE SPECIFIED:		APVD XU XIANG 02JUN2015	NAME H32B-TS/TG/TSH/TGH-RO-M/PG	
		PRODUCT SPEC 108-137013	RESTRICTED TO	
MATERIAL -		APPLICATION SPEC 114-137013	SIZE A200779	CAGE CODE C-T13X0320XXX000
FINISH -		WEIGHT -	DRAWING NO	SHEET 1 OF 2
		CUSTOMER DRAWING	SCALE 1:1	REV B

THIS DRAWING IS UNPUBLISHED. RELEASED FOR PUBLICATION 20  
 © COPYRIGHT 20 BY - ALL RIGHTS RESERVED.

REVISIONS				
P	LTR	DESCRIPTION	DATE	APVD
		SEE SHEET 1		

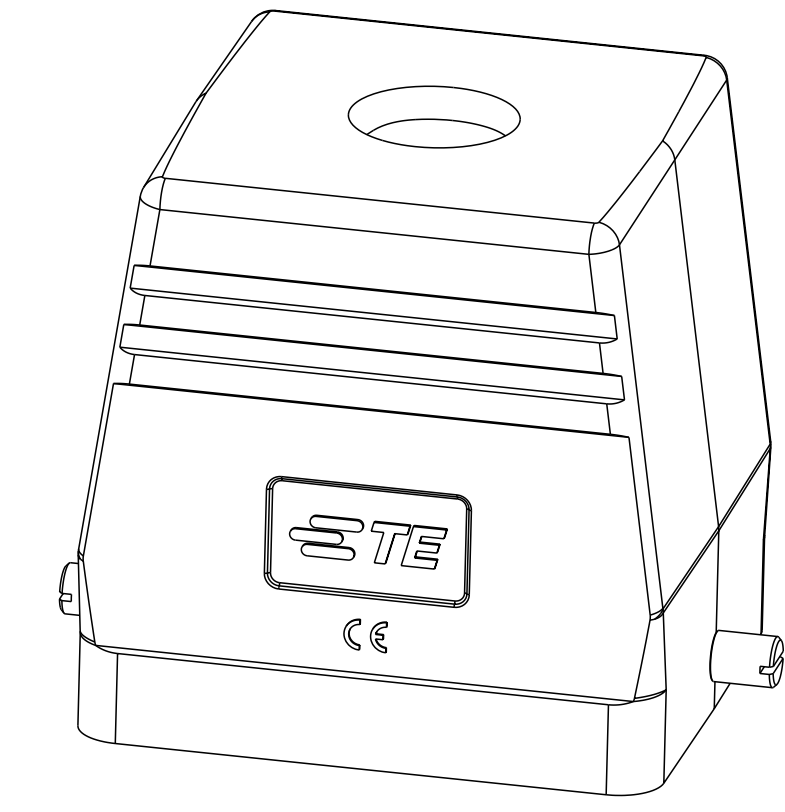
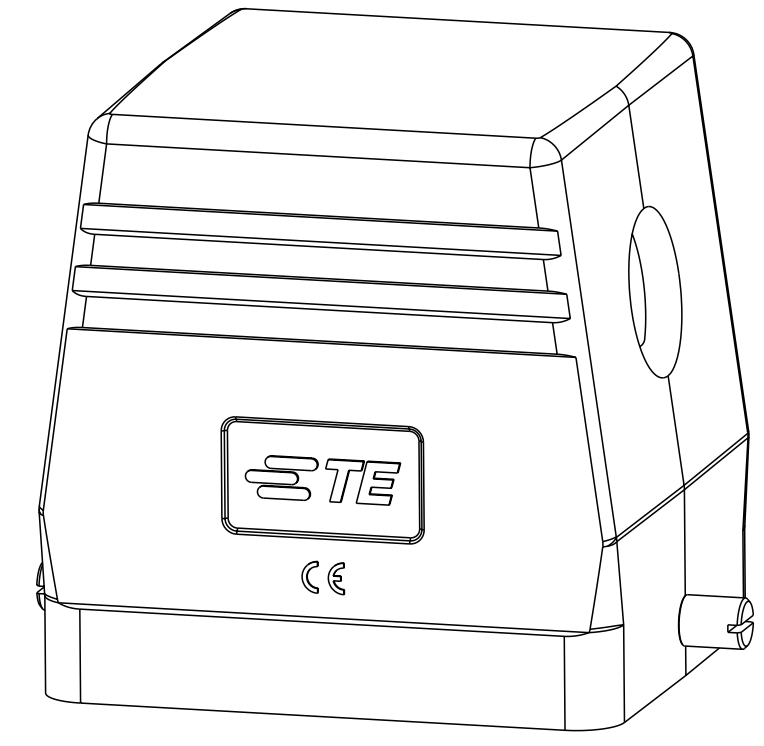
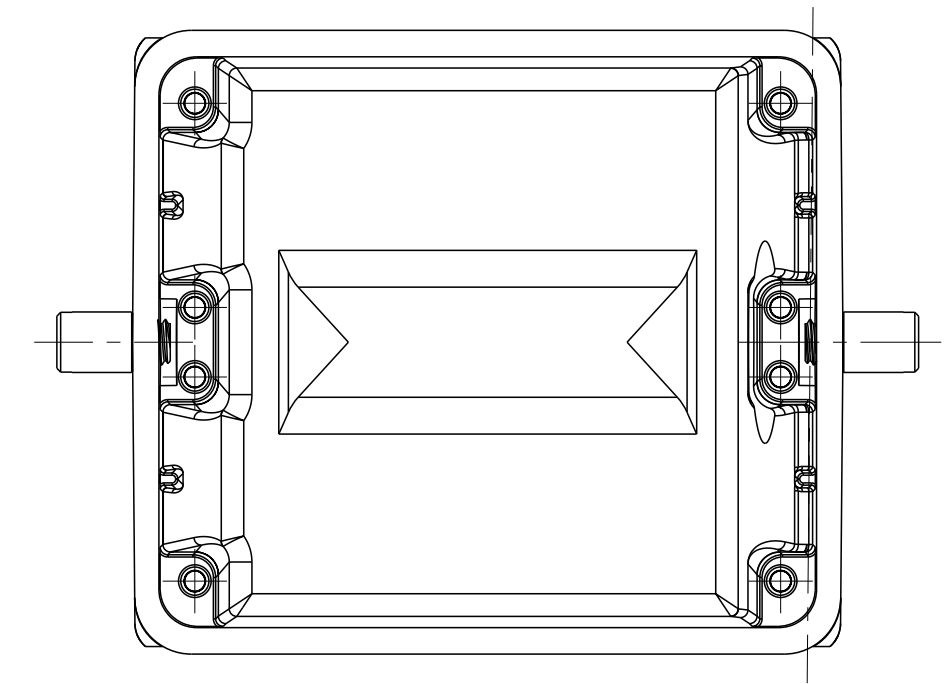
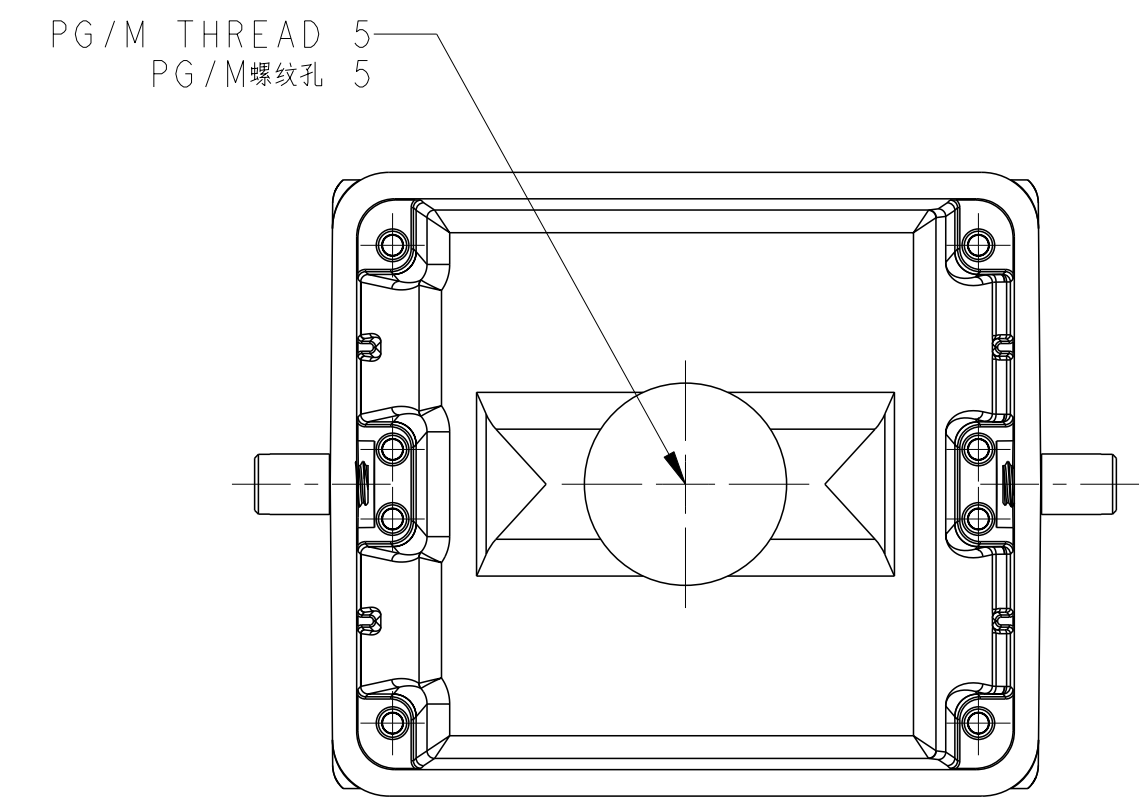
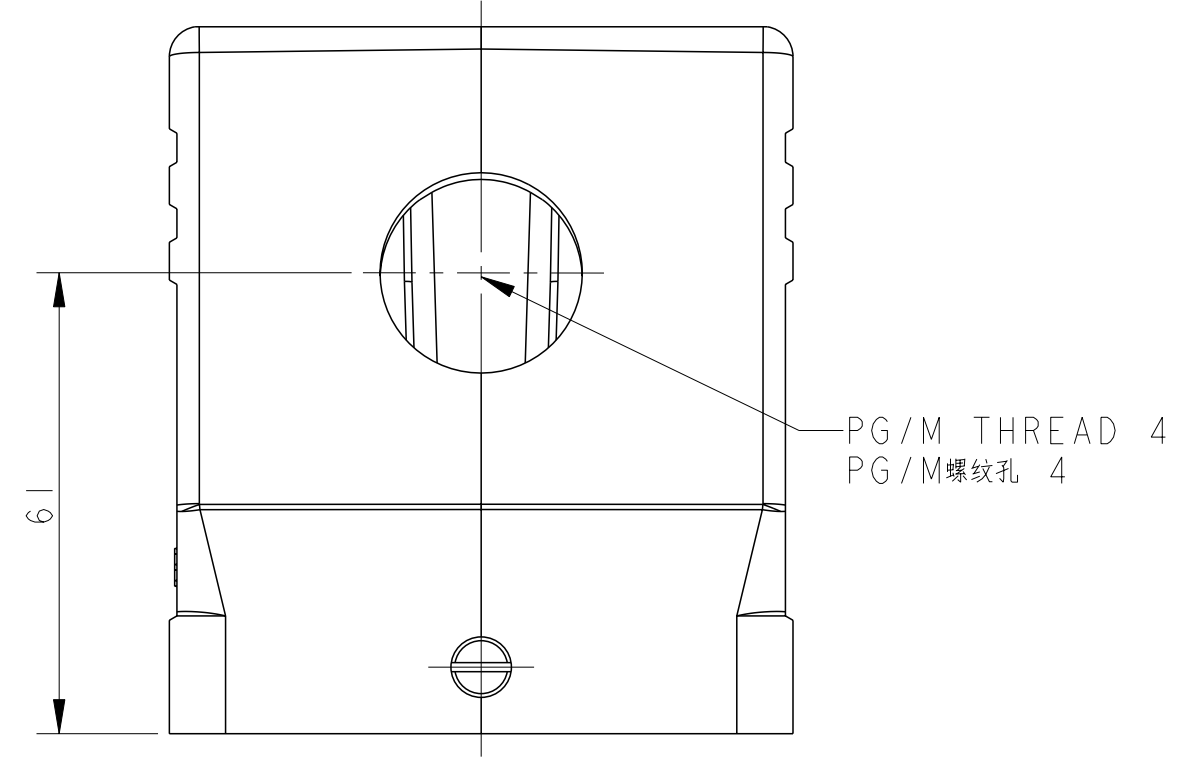
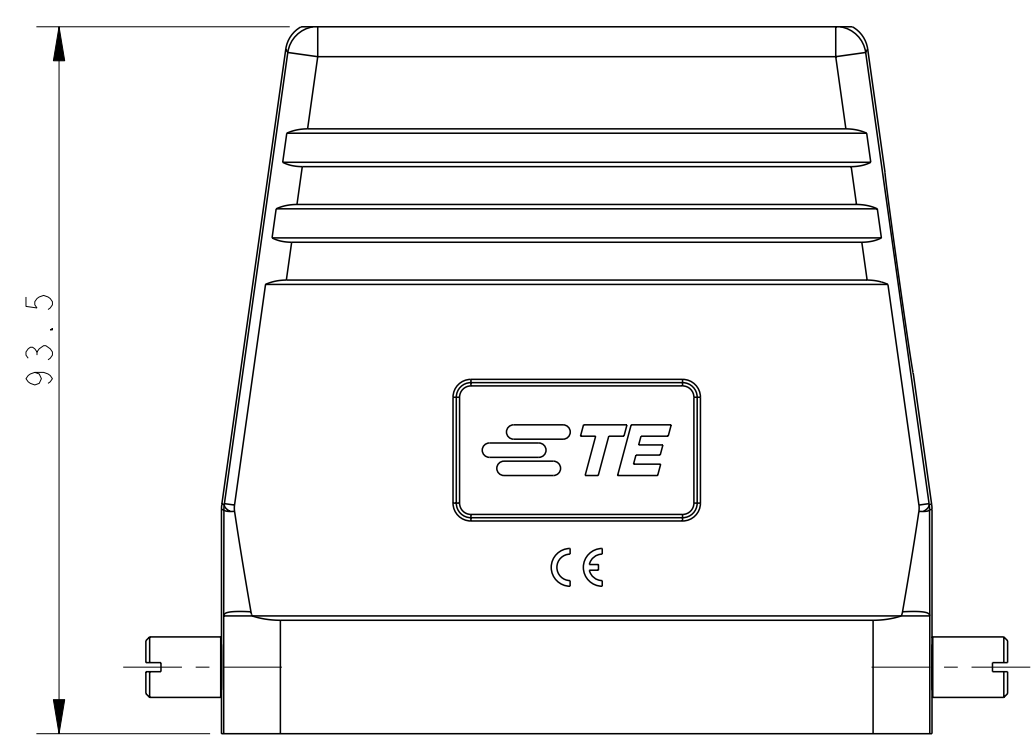

TYPE 4: HIGH CONSTRUCTION, SIDE ENTRY, UNDEFINED DIMENSIONS REFER TO TYPE 1.  
 类型4: 高结构, 侧出, 未定义尺寸 & 规格参照类型1.

TYPE 5: HIGH CONSTRUCTION, TOP ENTRY, UNDEFINED DIMENSIONS REFER TO TYPE 4.  
 类型5: 高结构, 顶出, 未定义尺寸 & 规格参照类型4.

Printed on 20 Aug 2021 14:44 (China Standard Time) from IE343646

PART NUMBER 料号	PART DESCRIPTION 描述	PG/M THREAD 4 PG/M螺纹孔4	PG/M THREAD 5 PG/M螺纹孔5	TYPE 类型
T1330320121-000	H32B-TSH-RO-PG21 H32B上壳, 侧出PG21, 2耳, 高结构, 灰色粉末喷涂	PG21	-	TYPE 4 类型4
T1330320129-000	H32B-TSH-RO-PG29 H32B上壳, 侧出PG29, 2耳, 高结构, 灰色粉末喷涂	PG29	-	
T1330320132-000	H32B-TSH-RO-M32 H32B上壳, 侧出M32, 2耳, 高结构, 灰色粉末喷涂	M32	-	
T1330320136-000	H32B-TSH-RO-PG36 H32B上壳, 侧出PG36, 2耳, 高结构, 灰色粉末喷涂	PG36	-	
T1330320140-000	H32B-TSH-RO-M40 H32B上壳, 侧出M40, 2耳, 高结构, 灰色粉末喷涂	M40	-	TYPE 5 类型5
T1340320121-000	H32B-TGH-RO-PG21 H32B上壳, 顶出PG21, 2耳, 高结构, 灰色粉末喷涂	-	PG21	
T1340320125-000	H32B-TGH-RO-M25 H32B上壳, 顶出M25, 2耳, 高结构, 灰色粉末喷涂	-	M25	
T1340320129-000	H32B-TGH-RO-PG29 H32B上壳, 顶出PG29, 2耳, 高结构, 灰色粉末喷涂	-	PG29	
T1340320132-000	H32B-TGH-RO-M32 H32B上壳, 顶出M32, 2耳, 高结构, 灰色粉末喷涂	-	M32	
T1340320136-000	H32B-TGH-RO-PG36 H32B上壳, 顶出PG36, 2耳, 高结构, 灰色粉末喷涂	-	PG36	
T1340320140-000	H32B-TGH-RO-M40 H32B上壳, 顶出M40, 2耳, 高结构, 灰色粉末喷涂	-	M40	
T1340320142-000	H32B-TGH-RO-PG42 H32B上壳, 顶出PG42, 2耳, 高结构, 灰色粉末喷涂	-	PG42	
T1340320150-000	H32B-TGH-RO-M50 H32B上壳, 顶出M50, 2耳, 高结构, 灰色粉末喷涂	-	M50	
T1340320163-000	H32B-TGH-RO-M63 H32B上壳, 顶出M63, 2耳, 高结构, 灰色粉末喷涂	-	M63	

THIS DRAWING IS A CONTROLLED DOCUMENT.		DWN DAVID LI 02JUN2015	TE Connectivity	
DIMENSIONS: mm		CHK CHRIS WANG 02JUN2015		
TOLERANCES UNLESS OTHERWISE SPECIFIED:		APVD XU XIANG 02JUN2015	NAME H32B-TS/TG/TSH/TGH-RO-M/PG	
0 PLC ± 1 PLC ± 2 PLC ± 3 PLC ± 4 PLC ± ANGLES ± FINISH		PRODUCT SPEC 108-137013	RESTRICTED TO	
MATERIAL -		APPLICATION SPEC 114-137013	SIZE A200779	CAGE CODE C-T13X0320XXX000
		WEIGHT -	DRAWING NO. 114-137013	
		CUSTOMER DRAWING	SCALE 1:1	SHEET 2 OF 2

# Mouser Electronics

Authorized Distributor

Click to View Pricing, Inventory, Delivery & Lifecycle Information:

[TE Connectivity:](#)

[T1310320132-000](#)