

PROPERTY OF DEUTSCH D.A.O.
 THIS DRAWING CONTAINS PROPRIETARY INFORMATION THAT SHALL NOT BE DISCLOSED, DUPLICATED,
 NOR USED IN WHOLE OR IN PART FOR ANY PURPOSE OTHER THAN TO EVALUATE THIS DRAWING.

N/C DTS23***-****

REVISIONS			
REV	DESCRIPTIONS	DATE	APPROVED
N/C	NEW RELEASE PER E.O.H4638	101025	MA

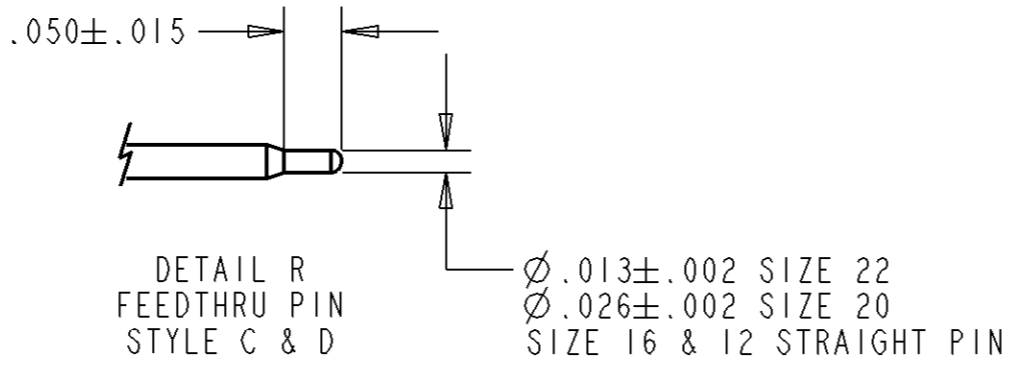
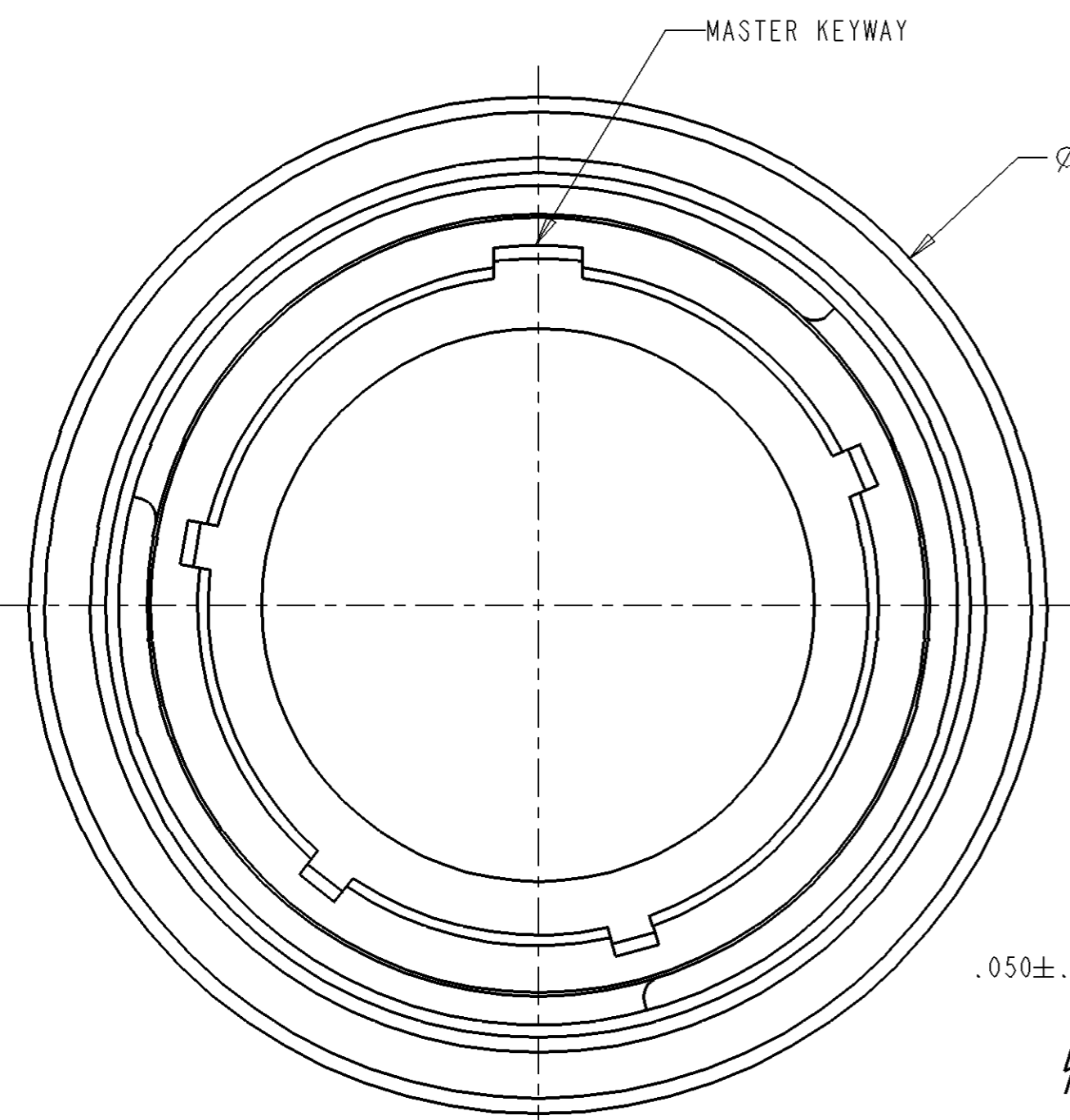

STUB 60° MOD
 TRIPLE START THREAD
 "D"-.1P-.3L CLASS 2A
 (SEE COLUMN "D THREAD")

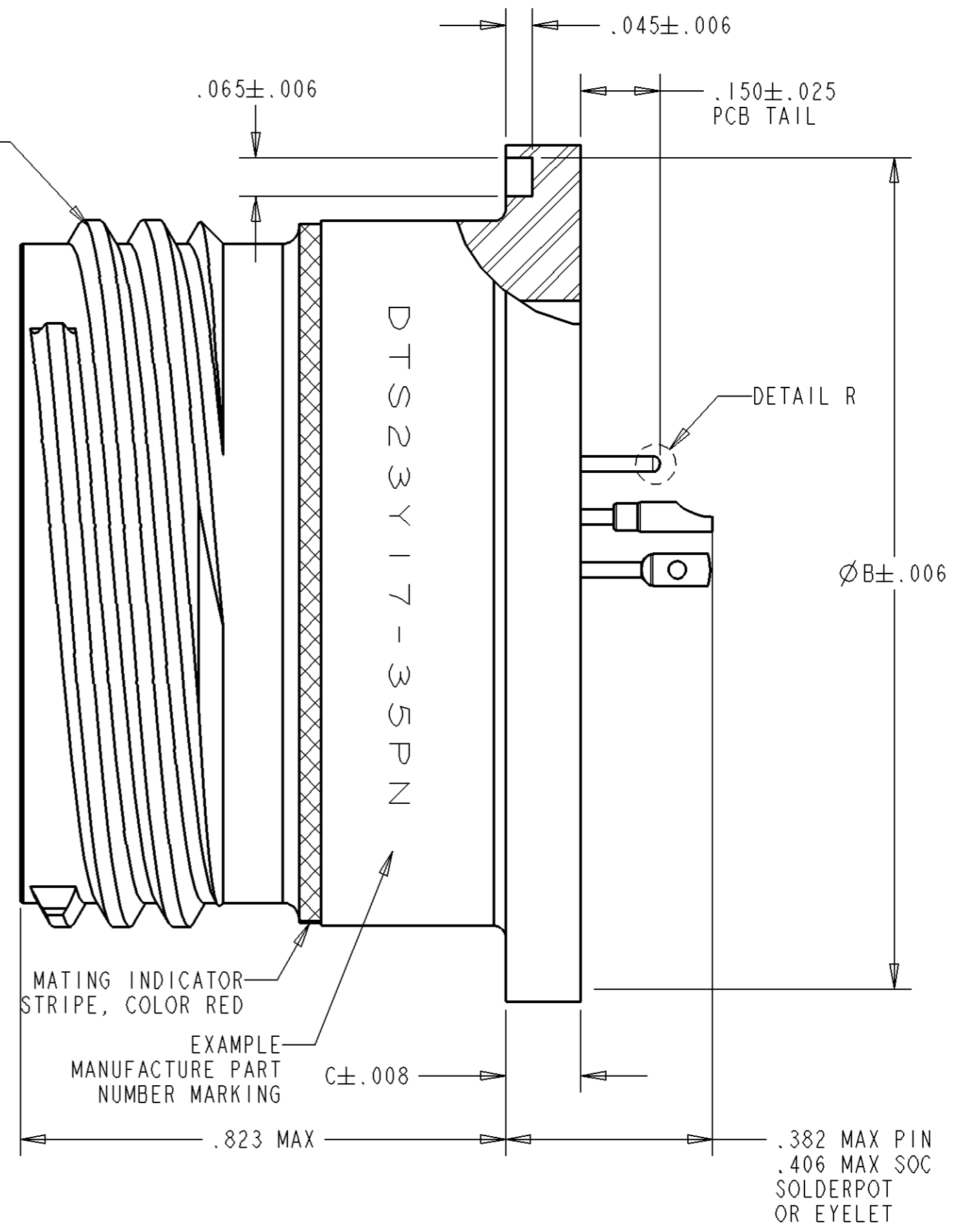

9. PART NUMBER BREAKDOWN: DTS 23 Y 17-35 P N

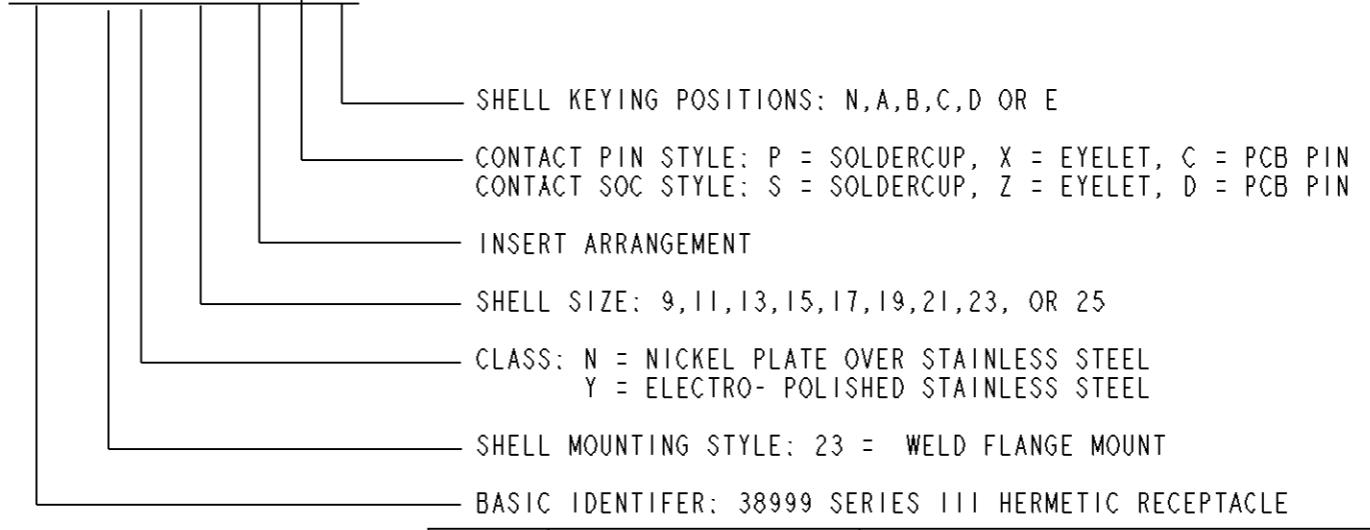

SECTION A-A

SHELL SIZE	A	B	C	D THREAD
9	.978	.935	.126	.6250
11	1.100	1.057	.126	.7500
13	1.226	1.183	.126	.8750
15	1.352	1.309	.126	1.0000
17	1.439	1.396	.126	1.1875
19	1.585	1.541	.126	1.2500
21	1.726	1.683	.126	1.3750
23	1.892	1.848	.157	1.5000
25	1.978	1.935	.157	1.6250

- DIMENSIONS ARE IN INCHES UNLESS OTHERWISE NOTED.
- INSERT ARRANGEMENT CONFORMS TO MIL-STD-1560.
- LEAK RATE: $< 1E-8$ cc/sec He @ 1 atm.
- FINISH: SHELL - ELECTRO-POLISH
 PIN CONTACTS - GOLD OVER NICKEL
- MATERIAL: SHELL - STAINLESS STEEL
 PIN CONTACTS - HIGH NICKEL IRON ALLOY OR EQUIVALENT
 GLASS - COMPRESSION GLASS
 INTERNAL SEAL - FLUOROSILICONE ELASTOMER
- MATES WITH DTS26 PLUG CONNECTOR.
- CONNECTOR MEETS REQUIREMENTS OF MIL-DTL-38999 SERIES III.
- CONSULT SALE STAFF FOR ARRANGEMENT AVAILABILITY.

NOTE(S):

	SIGNATURE & DATE
DR	S.LUI 10/21/96
CHK	L.STOLLE 10/22/96
PE	
APPD	J.AGUILERA 10/22/96
SCALE:	NONE

CONNECTOR, RECEPTACLE

HERMETIC
 WELD FLANGE MOUNT
 THREAD COUPLING
 MIL-DTL-38999/27

ENVELOPE

CP	MATL CODE 72
DEUTSCH ENGINEERED INTERCONNECT SOLUTIONS 250 Eddie Jones Way Oceanside, CA 92058	
C	DTS23***-****
DWG SIZE	CAGE CODE 11139 SHEET 1 OF 1

FILE:DTS23XXX-XXXX-ENV

Mouser Electronics

Authorized Distributor

Click to View Pricing, Inventory, Delivery & Lifecycle Information:

[TE Connectivity:](#)

[YDTS23Y11-35PNV001](#)