

NOTES:
 1. MARKED WITH TE PART NUMBER, TE (HASTINGS) CAGE CODE, DATE CODE AND REAR CONTACT LOCATION MARKING WHERE SHOWN. SEE SHEET 2 FOR TEXT AND POSITIONS.

PART NUMBER EXAMPLE: **D369 - MP 3 3 - N P 1**

BASIC PART No. _____
 SHELL STYLE (MP = METALLIZED PLUG) _____
 SHELL SIZE _____
 CONTACT QTY _____
 (3 = 3 x #22's)

CONTACT CONFIGURATION 4. _____
 CONTACT TYPE (P = PIN, S = SKT) _____
 SHELL KEYING _____

2. PERFORMANCE:
 TEMPERATURE RANGE : -55°C TO +175°C. INSULATION RESISTANCE : ≥5000 MΩ.
 DIELECTRIC WITHSTAND: 1500VRMS, <2mA. SEALING: 18KM(60000FT) ALTITUDE / IP67
 DURABILITY : 500 MATING CYCLES MIN. FLUID RESISTANCE: I.A.W. EN2591-315.
 FLAMMABILITY, SMOKE AND TOXICITY: I.A.W. FAR 25.853 APPENDIX F.

3. INSERTION/EXTRACTION TOOL (M81969/14-01 OR EQUIVALENT) SUPPLIED SEPARATELY.

Contact Configuration	Contact Description	Contact P/N (OR EQUIVALENT)		Crimp Positioner		Crimp Tool	Wire Accommodation	Current Rating
		Pin	Socket	Pin	Socket			
0		NO CONTACTS SUPPLIED						
1	CRIMP, COPPER WIRE	38941-22L	38946-22L	M22520/2-09	M22520/2-06	M22520/2-01	22-26 AWG	5A (22 AWG)
2	CRIMP, ALUMINIUM WIRE	200-1042-22	200-1142-22	KAL2		ALNP 22-A	22 AWG	5A
3	CRIMP, COPPER WIRE (ENLARGED WIRE)	182-0860-22	182-0862-22	M22520/2-09	M22520/2-06	M22520/2-01	20-24 AWG	7.5A (20 AWG)**

** UPPER TEMPERATURE LIMIT DE-RATED TO +133°C AT 7.5A (20 AWG)

5. MATERIALS & FINISHES:

COMPONENT	MATERIAL	FINISH
SEALS	SILICONE / FLUOROSILICONE BLEND RUBBER PER AMS-R-25988 TYPE II, CLASS I, GRADE 40	N/A
INSERT COMPONENTS	POLYETHERIMIDE, 10% GLASS FILLED PER ASTM D 5205 or POLYETHERETHERKETONE 450G	N/A
SHELL BODY	POLYETHERIMIDE, 10% GLASS FILLED PER ASTM D 5205	ELECTROLESS NICKEL PLATED

NICKEL PLATED FINISH MAY VARY IN COSMETIC APPEARANCE. PLATING MAY BE DULL IN APPEARANCE WITH A ROUGH SURFACE, OR SHINY IN APPEARANCE WITH A SMOOTH SURFACE. THIS IN NO WAY AFFECTS THE FORM, FIT OR FUNCTION OF THE PRODUCT, OR THE ENVIRONMENTAL PERFORMANCE OF THE PLATED FINISH. IT SHOULD BE CONSIDERED A VISUAL VARIATION ONLY.

6. MAXIMUM WEIGHT (WITHOUT CONTACTS): 3.4g (PIN INSERT), 3.5(SKT INSERT).

7. EMI SHIELDING PERFORMANCE (MATED PAIR):

FREQUENCY (MHz)	150	200	300	400	800	1000	1500	2000	3000	4000	6000	10000
ATTENUATION (dB)	65	60	55	55	45	43	40	37	35	33	30	20

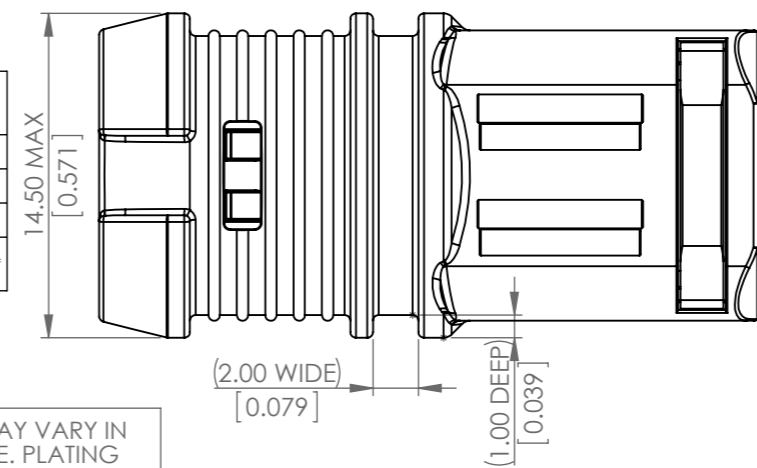
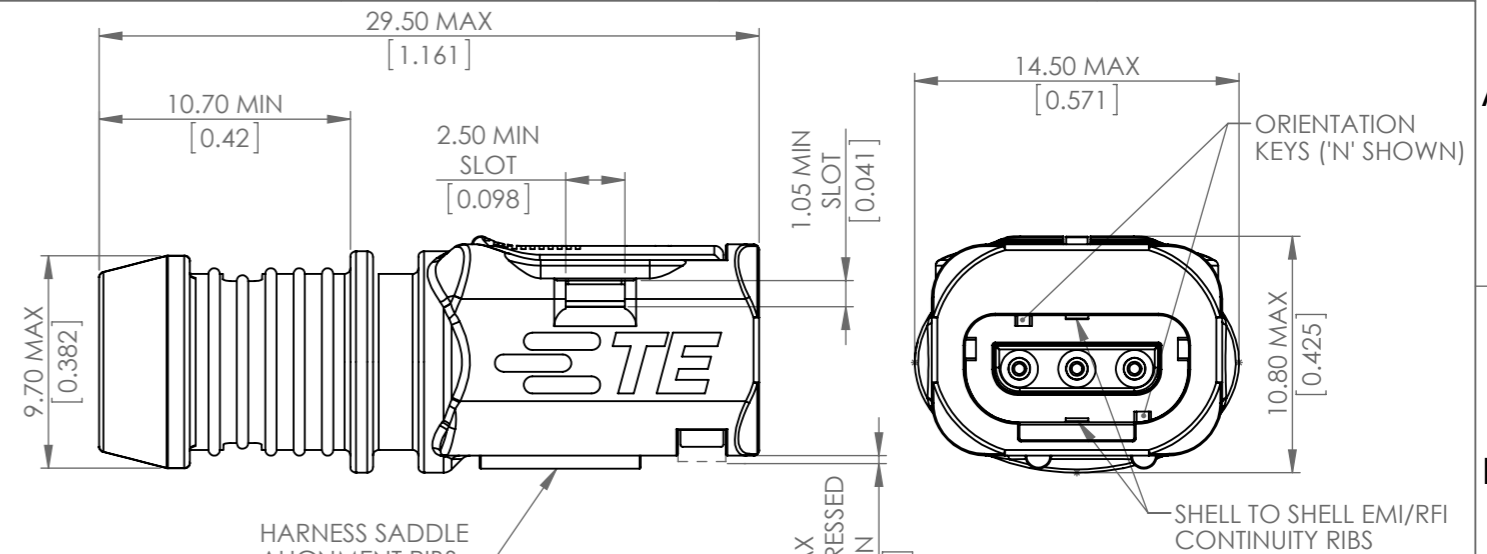

SHELL KEYING	
ORIENTATION	COLOUR CODING STRIPE
N	BLACK
A	DARK RED
B	DARK BLUE
C	DARK GREEN
D	YELLOW

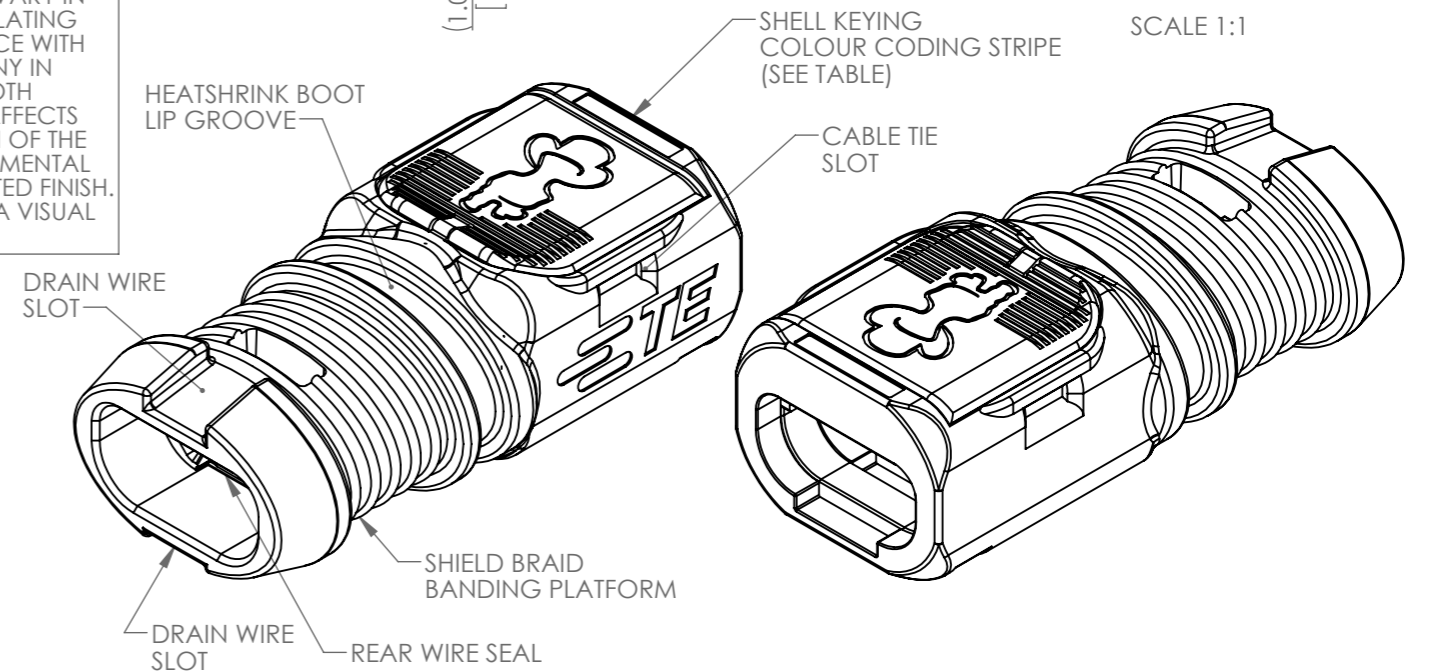
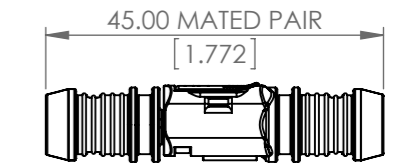

THE CONNECTOR DESCRIBED ON THIS DRAWING SHALL MEET THE QUALIFICATION REQUIREMENTS AS OUTLINED IN TE QTP 109-163002

BS8888 THIRD ANGLE PROJECTION	MATERIAL: SEE NOTE 5	FINISH: SEE NOTE 5	 DEUTSCH TE CONNECTIVITY UK LTD., ST. LEONARDS-ON-SEA, TN38 9RF, UK.
UNLESS OTHERWISE STATED: DIMENSIONS: mm [INCHES]	TITLE: SHIELDED D369 PLUG SHELL SIZE 3, 3 WAY TYPE: CUSTOMER DRAWING		
IF IN DOUBT, ASK	SIZE: A3	SCALE: 3:1	DRAWING NUMBER: 612081-3-ENV
			SHEET: 1 OF 2 ISSUE: AD

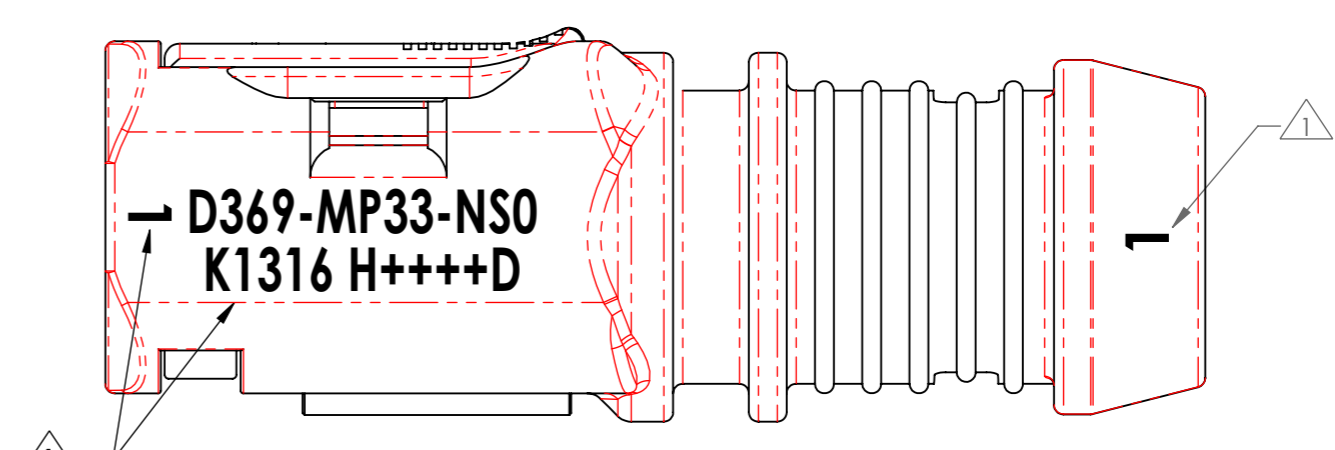
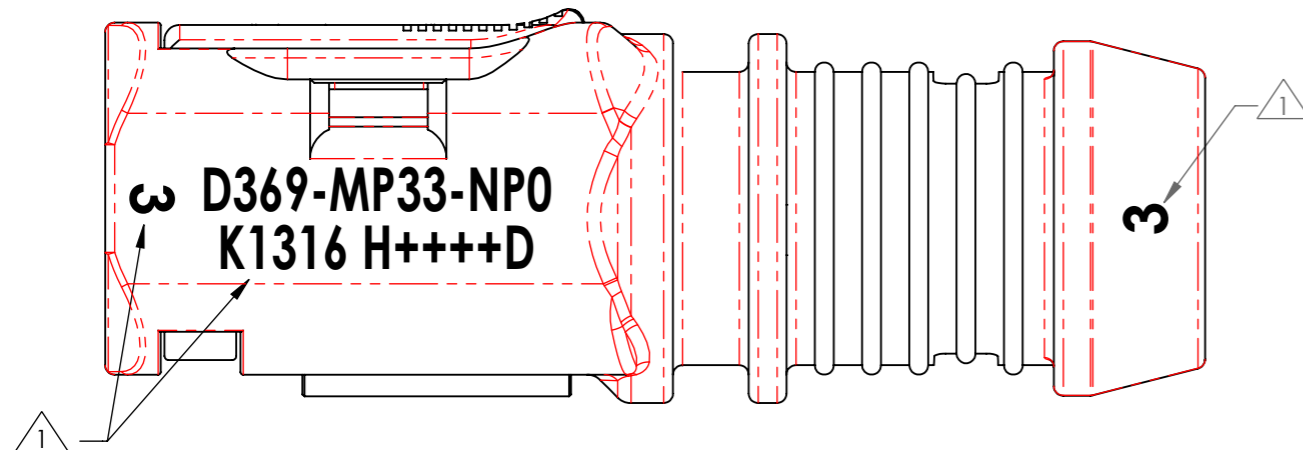
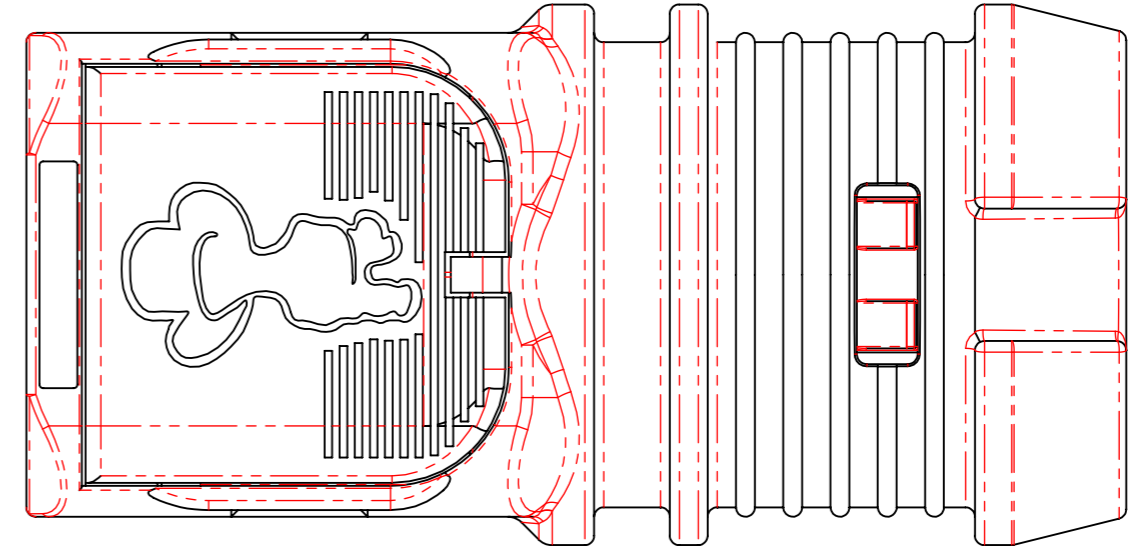
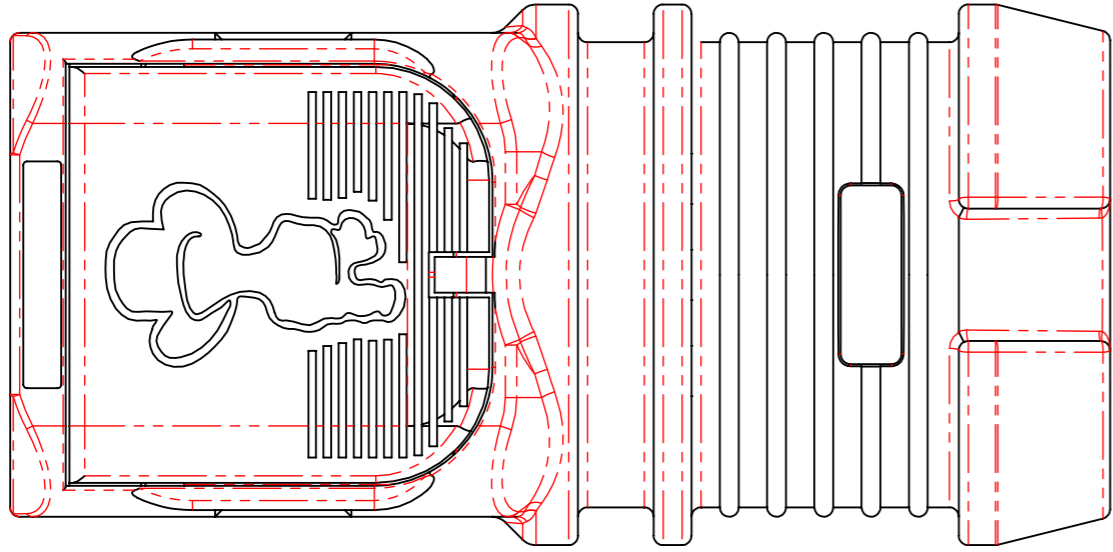

AD	DUK-68755	KSC	GDM	KJF	CEO	23/11/2017
ISSUE	CHANGE NOTE	DRAWN	CHECKED	APP. ENG.	APP. MARKETING	DATE



3 WAY PLUG (PIN/MALE CONTACTS)

3 WAY PLUG (SOCKET/FEMALE CONTACTS)

THE CONNECTOR DESCRIBED ON THIS DRAWING SHALL MEET THE QUALIFICATION REQUIREMENTS AS OUTLINED IN TE QTP 109-163002

BS8888 THIRD ANGLE PROJECTION 	MATERIAL: SEE NOTE 5	FINISH: SEE NOTE 5	 DEUTSCH TE CONNECTIVITY UK LTD., ST. LEONARDS-ON-SEA, TN38 9RF, UK.	
	TITLE: SHIELDED D369 PLUG SHELL SIZE 3, 3 WAY			
UNLESS OTHERWISE STATED: DIMENSIONS: mm [INCHES]	SIZE: A3	SCALE: 5:1	DRAWING NUMBER: 612081-3-ENV	SHEET: 2 OF 2
IF IN DOUBT, ASK				ISSUE: AD

THIS INFORMATION IS CONFIDENTIAL AND PROPRIETARY TO TYCO ELECTRONICS CORPORATION AND ITS WORLDWIDE SUBSIDIARIES AND AFFILIATES (TE). IT MAY NOT BE DISCLOSED TO ANYONE OTHER THAN TE PERSONNEL, WITHOUT AUTHORIZATION FROM TE (www.te.com).

Mouser Electronics

Authorized Distributor

Click to View Pricing, Inventory, Delivery & Lifecycle Information:

[TE Connectivity:](#)

[YD369-MP33-NP10000](#)