

THIS DRAWING IS UNPUBLISHED. RELEASED FOR PUBLICATION  
 © COPYRIGHT - By - ALL RIGHTS RESERVED.

LOC		DIST		REVISIONS			
P	LTR	DESCRIPTION	DATE	DWN	APVD		
FT	0	W	REVISED PER ECO-12-012316	05JUL12	KH	MZ	

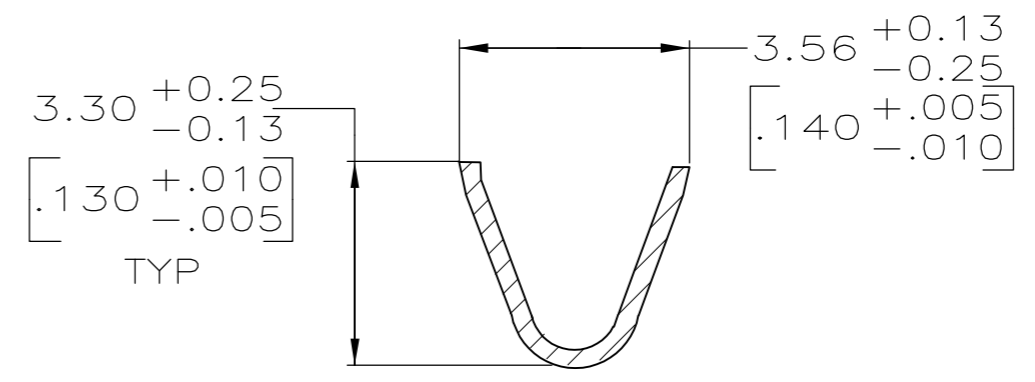
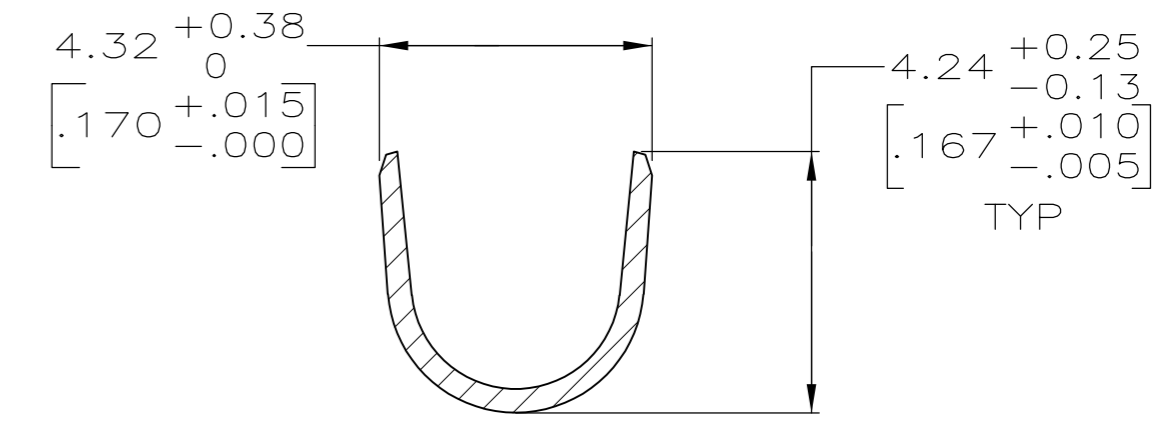
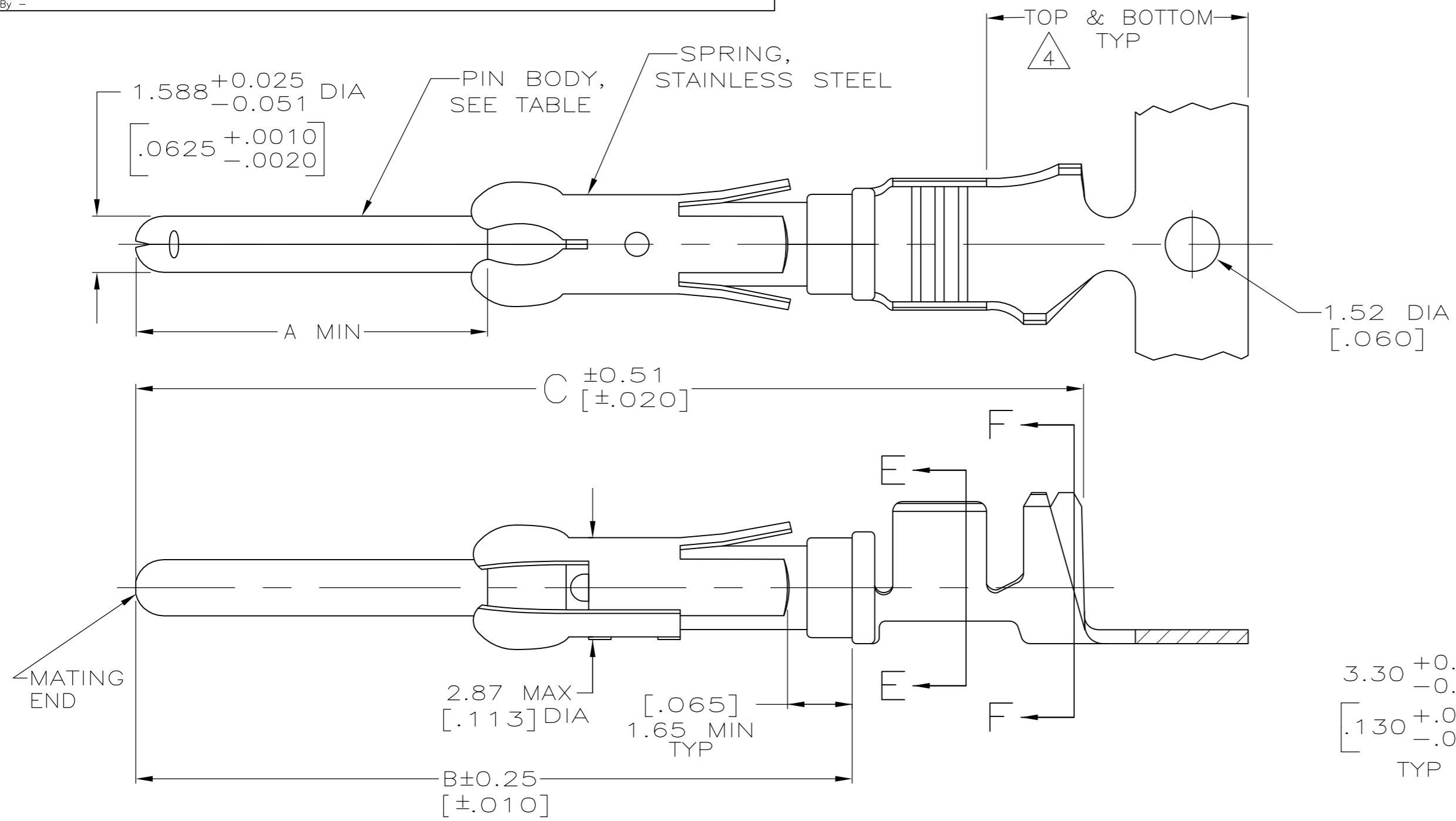

- 1 REELED FOR MINI-APPLICATOR.
- 2  $0.76\mu\text{m}$   $[\text{.000030}]$  MIN PRECIOUS METAL PLATE ON MATING END FOR A LENGTH OF  $5.08$   $[\text{.200}]$  MIN OVER  $1.27\mu\text{m}$   $[\text{.000050}]$  MIN NICKEL PLATE. GOLD FLASH ALL OVER. CONFORMS TO THE REQUIREMENTS OF TE CONNECTIVITY PRODUCT SPEC 108-10042, BASED ON EIA/ECA-364-1000.01A ( CONTROLLED ENVIRONMENT APPLICATIONS ).
- 3  $1.27\mu\text{m}$   $[\text{.000050}]$  MIN TIN-LEAD PER MIL-T-10727 OVER  $1.27\mu\text{m}$   $[\text{.000050}]$  MIN NICKEL PER QQ-N-290.
- 4 GOLD PLATING NEED NOT APPEAR IN THIS AREA.
- 5 BRASS
- 6 PHOSPHOR BRONZE
- 7 WIRE RANGE 14-18 AWG.
- 8 INSULATION RANGE  $2.79[\text{.110}]$ - $3.81[\text{.150}]$  DIA.
- 9  $0.38\mu\text{m}$   $[\text{.000015}]$  MIN GOLD PER MIL-G-45204 ON MATING END FOR A LENGTH OF  $5.08$   $[\text{.200}]$  MIN,  $1.27\mu\text{m}$   $[\text{.000050}]$  MIN TIN-LEAD PER MIL-T-10727 FOR A LENGTH OF  $5.69$   $[\text{.224}]$  MIN ON OPPOSITE END, BOTH OVER  $1.27\mu\text{m}$   $[\text{.000050}]$  MIN NICKEL PER QQ-N-290 ON ENTIRE CONTACT.
- 10 OBSOLETE PART NUMBER.
- 11  $1.27\mu\text{m}$   $[\text{.000050}]$  MIN TIN PER MIL-T-10727 OVER  $1.27\mu\text{m}$   $[\text{.000050}]$  MIN NICKEL PER Q-N-290.
- 12 COPPER NICKEL ALLOY.
- 13  $0.38\mu\text{m}$   $[\text{.000015}]$  MIN GOLD PER MIL-G-45204 ON MATING END FOR A LENGTH OF  $5.08$   $[\text{.200}]$  MIN. WITH GOLD FLASH ON THE REMAINDER, OVER  $1.27\mu\text{m}$   $[\text{.000050}]$  MIN NICKEL PER QQ-N-290.
- 14 PRELIMINARY - NOT FOR PRODUCTION.

- 15 OBSOLETE PARTS: OBSOLETE CIS STREAMLINING PER D.RENAUD/D.SINISI
- 16  $0.76\mu\text{m}$   $[\text{.000030}]$  MIN PRECIOUS METAL PLATE ON MATING END FOR A LENGTH OF  $5.08$   $[\text{.200}]$  MIN WITH  $1.27\mu\text{m}$   $[\text{.000050}]$  MIN MATTE TIN PLATE IN WIRE CRIMP AREA, BOTH OVER  $1.27\mu\text{m}$   $[\text{.000050}]$  MIN NICKEL PLATE. CONFORMS TO THE REQUIREMENTS OF TE CONNECTIVITY PRODUCT SPEC 108-10042, BASED ON EIA/ECA-364-1000.01A ( CONTROLLED ENVIRONMENT APPLICATIONS ).

	26.75[1.053]	20.24[.797]	9.91[.390]	1	13	12	-	14	1-66597-2
	26.75[1.053]	20.24[.797]	9.91[.390]	1	11	12	1-66602-0		1-66597-1
	26.75[1.053]	20.24[.797]	9.91[.390]	1	2	12	66602-9		1-66597-0
15 OBSOLETE	26.75[1.053]	20.24[.797]	9.91[.390]	1	11	6	-		<del>66597-9</del>
	26.75[1.053]	20.24[.797]	9.91[.390]	1	11	5	66602-8		66597-8
OBSOLETE	26.75[1.053]	20.24[.797]	9.91[.390]	1	9	5	<del>66602-5</del>		<del>66597-7</del>
OBSOLETE	30.43[1.198]	23.93[.942]	13.59[.535]	1	3	5	-		<del>66597-6</del>
OBSOLETE	26.75[1.053]	20.24[.797]	9.91[.390]	1	2	6	66602-4		66597-5
OBSOLETE	26.75[1.053]	20.24[.797]	9.91[.390]	1	3	6	66602-3		66597-4
	26.75[1.053]	20.24[.797]	9.91[.390]	1	16	5	66602-2		66597-2
	26.75[1.053]	20.24[.797]	9.91[.390]	1	3	5	66602-1		66597-1
	C	B	A	REELING	PIN BODY FINISH	PIN BODY	LOOSE PIECE REF		PART NO

THIS DRAWING IS A CONTROLLED DOCUMENT.

DIMENSIONS: mm [INCHES]	TOLERANCES UNLESS OTHERWISE SPECIFIED: 0 PLC ± - 1 PLC ± - 2 PLC ± 0.13[.005] 3 PLC ± - 4 PLC ± - ANGLES ± -	DWN R.SHIREY 7-22-91 CHK R.STONE 8-15-91 APVD J.WESTMAN 8-19-91 PRODUCT SPEC APPLICATION SPEC	NAME Renaud/Sinisi
MATERIAL SEE CALLOUTS	FINISH SEE TABLE	WEIGHT -	SIZE A2
CUSTOMER DRAWING		SCALE 8:1	SHEET 1 of 1

TE Connectivity  
 PIN ASSEMBLY, .062, TYPE III+  
 CAGE CODE 00779  
 DRAWING NO 66597  
 RESTRICTED TO  
 REV W

# Mouser Electronics

Authorized Distributor

Click to View Pricing, Inventory, Delivery & Lifecycle Information:

[TE Connectivity:](#)

[66597-5](#)