

REVISONS		DATE	BY	APPV
A3	REVISED PER ECO-13-005565	01APR13	KH	JO

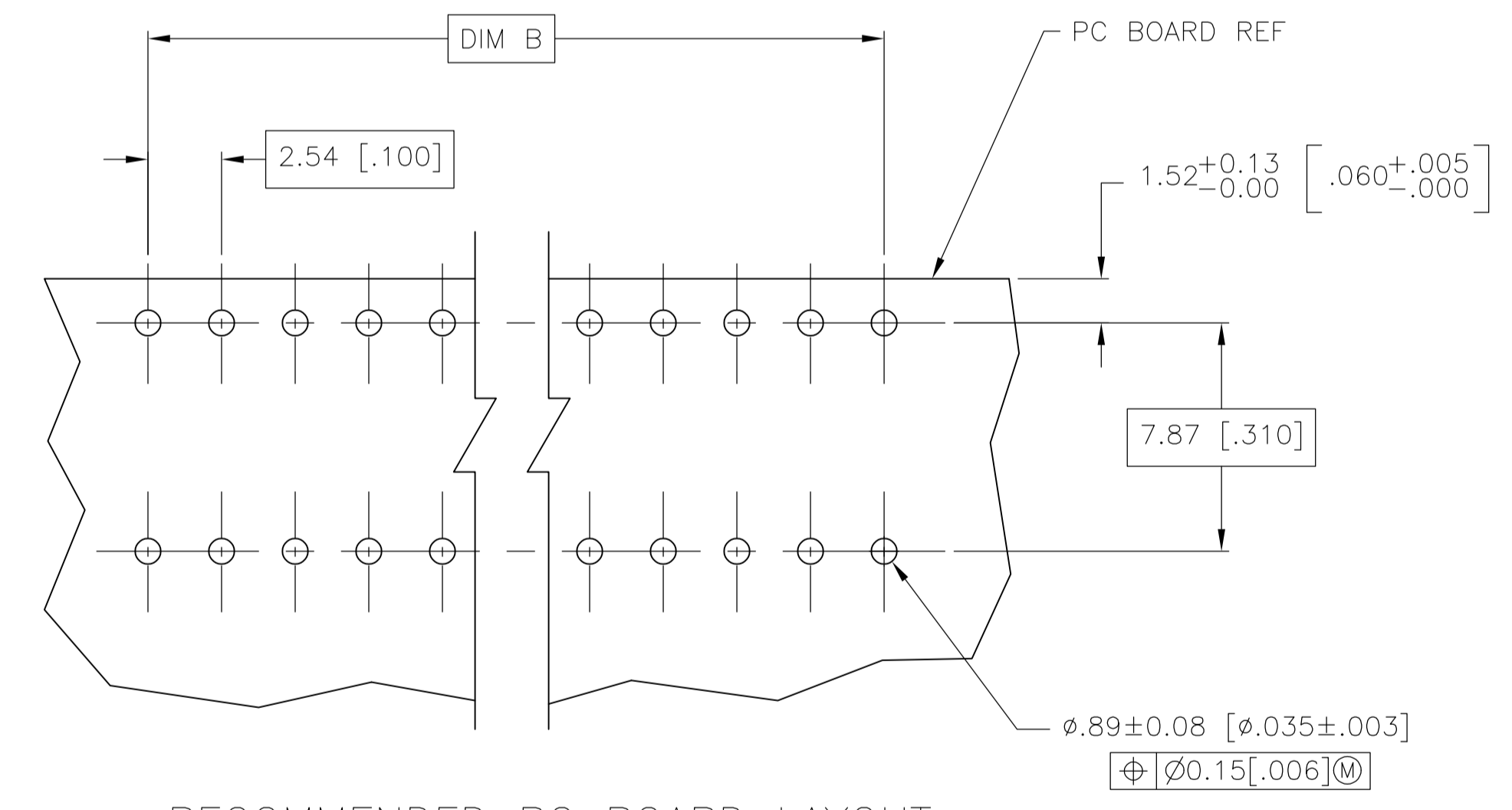
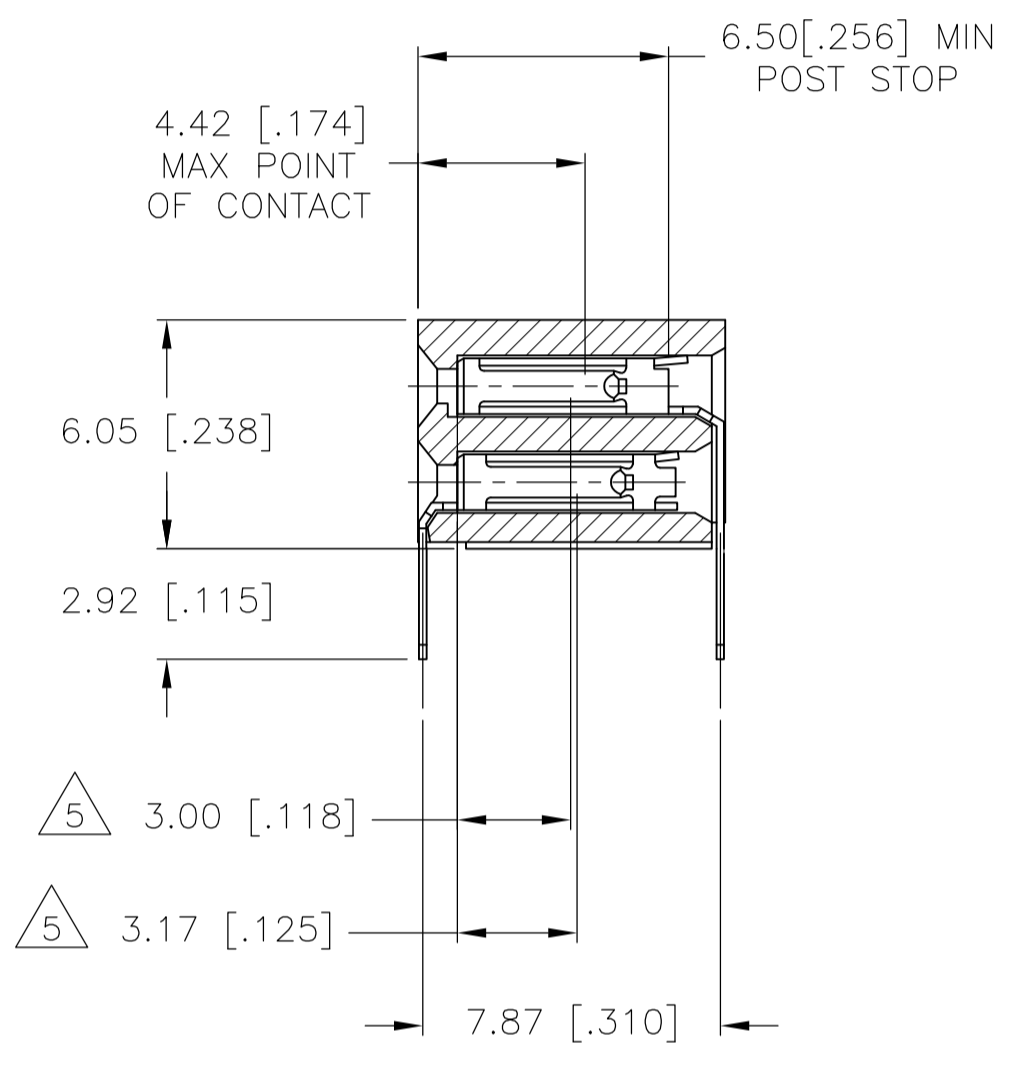
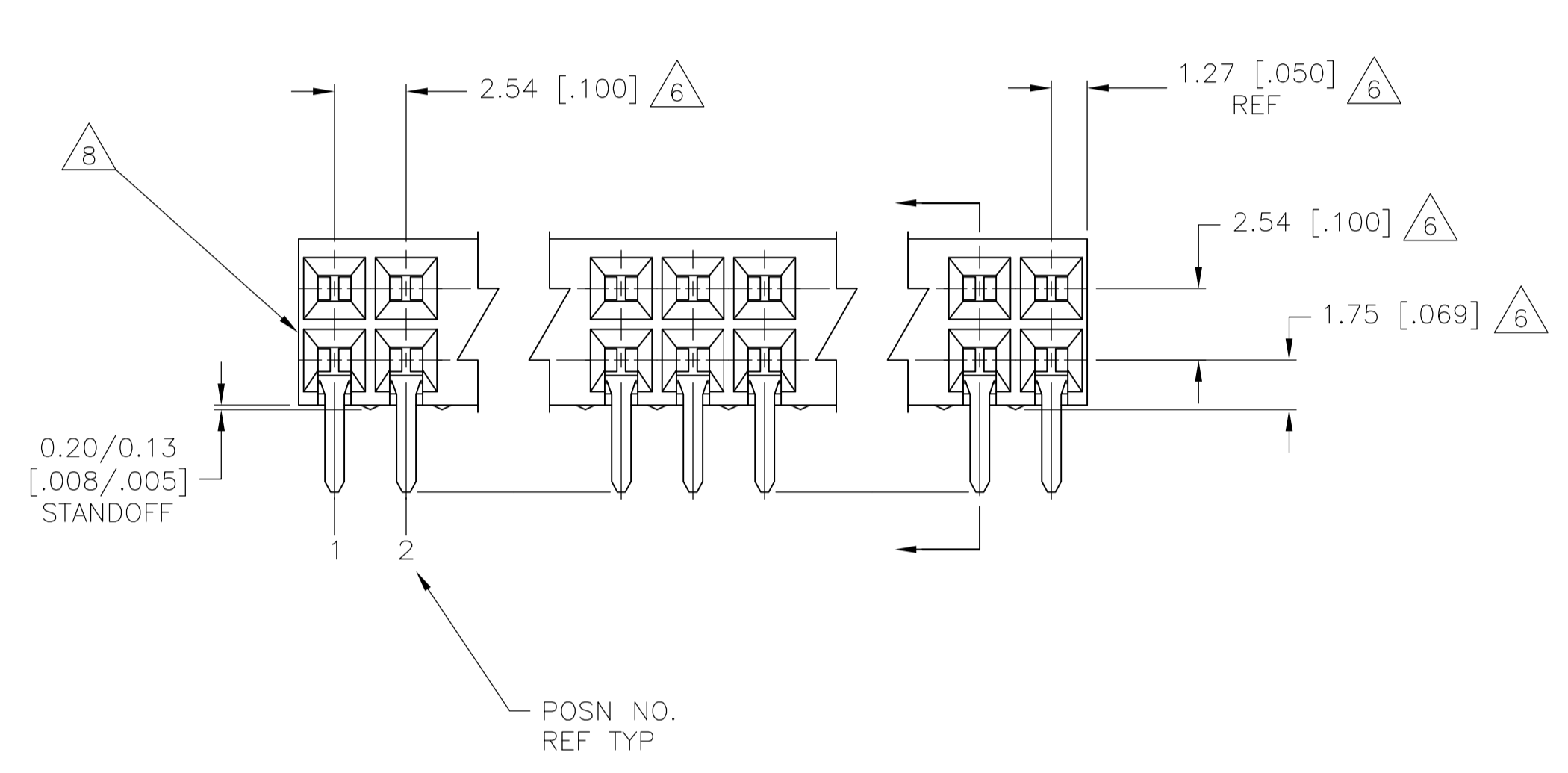
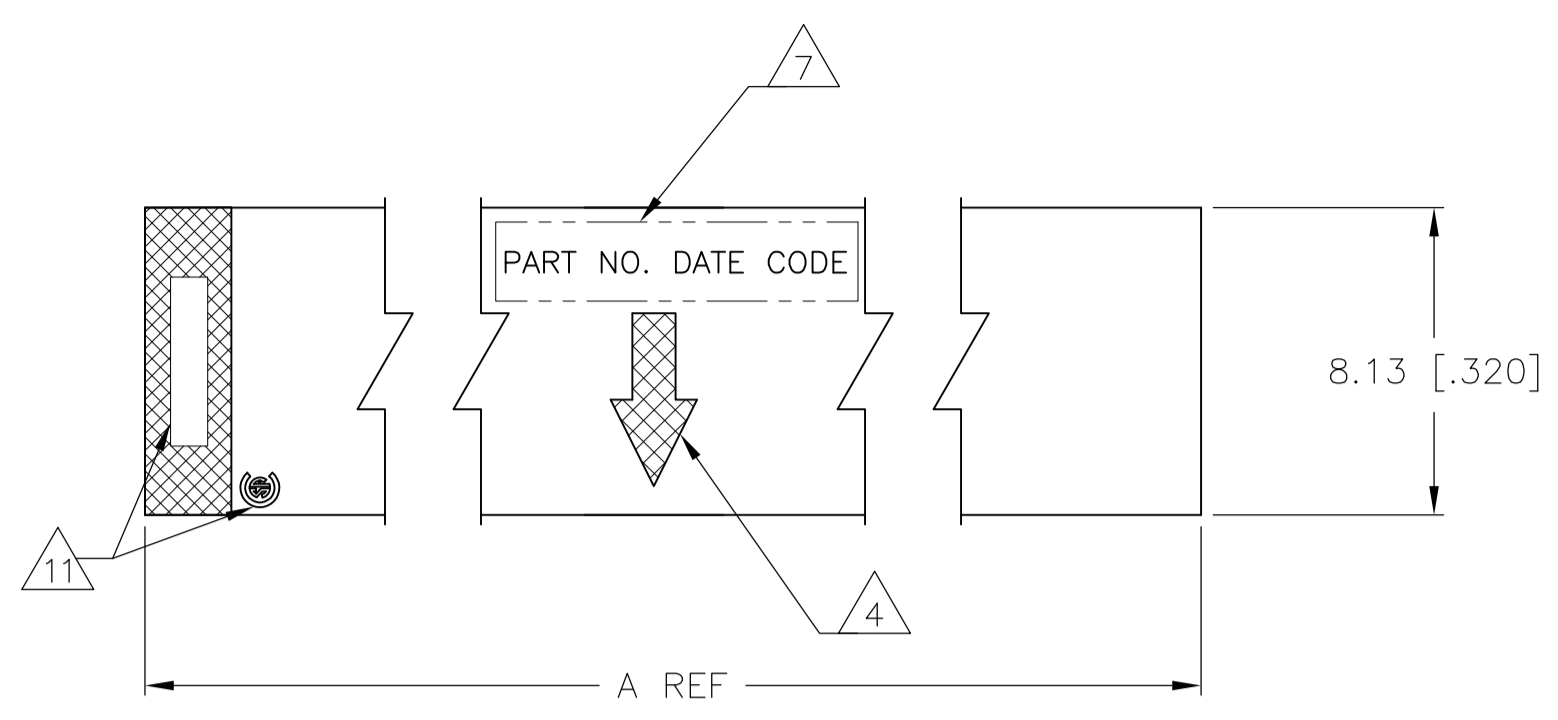

RECOMMENDED PC BOARD LAYOUT

- 1 HOUSING MATERIAL: GLASS FILLED POLYESTER, COLOR- BLACK
- 2 CONTACT MATERIAL: PHOSPHOR BRONZE
- 3 CONTACT FINISH: 0.00025[.000010] THK DUPLEX PLATED GOLD ON CONTACT AREA, 3.81-7.62(.000150-.000300) MATTE TIN ALL OVER 0.00127(.000050) NICKEL.
- 4 MOLDED IN ARROW DESIGNATES THE MATING FACE OF THE CONNECTOR
- 5 POINT OF MEASUREMENT FOR PLATING THICKNESS OF CONTACT AREA
- 6 DIMENSIONS PERTAIN TO HOUSING CAVITY CENTERLINES
- 7 MARK PART NUMBER AND DATE CODE MARKED IN APPROXIMATE LOCATION SHOWN, EITHER END.
- 8 ALTERNATE LOCATION FOR DATE CODE FOR 4 AND 6 POSITION.
- 9 NO PART NUMBER MARKING REQUIRED FOR THIS PART.
- 10 ROHS 2002/95/EC COMPLIANT.
- 11 TE LOGO AND CSA LOGO ARE MOLDED INTO HOUSING, THIS LOCATION.

162.56[6.400]	165.10[6.500]	130	6-5146140-4
160.02[6.300]	162.56[6.400]	128	6-5146140-3
157.48[6.200]	160.02[6.300]	126	6-5146140-2
154.94[6.100]	157.48[6.200]	124	6-5146140-1
152.40[6.000]	154.94[6.100]	122	6-5146140-0
149.86[5.900]	152.40[6.000]	120	5-5146140-9
147.32[5.800]	149.86[5.900]	118	5-5146140-8
144.78[5.700]	147.32[5.800]	116	5-5146140-7
139.70[5.500]	144.78[5.700]	114	5-5146140-6
139.70[5.500]	142.24[5.600]	112	5-5146140-5
137.16[5.400]	139.70[5.500]	110	5-5146140-4
134.62[5.300]	137.16[5.400]	108	5-5146140-3
132.08[5.200]	134.62[5.300]	106	5-5146140-2
129.54[5.100]	132.08[5.200]	104	5-5146140-1
127.00[5.000]	129.54[5.100]	102	5-5146140-0
124.46[4.900]	127.00[5.000]	100	4-5146140-9
121.92[4.800]	124.46[4.900]	98	4-5146140-8
119.38[4.700]	121.92[4.800]	96	4-5146140-7
116.84[4.600]	119.38[4.700]	94	4-5146140-6
114.30[4.500]	116.84[4.600]	92	4-5146140-5
111.76[4.400]	114.30[4.500]	90	4-5146140-4
109.22[4.300]	111.76[4.400]	88	4-5146140-3
106.68[4.200]	109.22[4.300]	86	4-5146140-2
104.14[4.100]	106.68[4.200]	84	4-5146140-1
101.16[4.000]	104.14[4.100]	82	4-5146140-0
99.06[3.900]	101.16[4.000]	80	3-5146140-9
96.52[3.800]	99.06[3.900]	78	3-5146140-8
93.98[3.700]	96.52[3.800]	76	3-5146140-7
91.44[3.600]	93.98[3.700]	74	3-5146140-6
88.90[3.500]	91.44[3.600]	72	3-5146140-5
86.36[3.400]	88.90[3.500]	70	3-5146140-4
83.82[3.300]	86.36[3.400]	68	3-5146140-3
81.28[3.200]	83.82[3.300]	66	3-5146140-2
78.74[3.100]	81.28[3.200]	64	3-5146140-1
76.20[3.000]	78.74[3.100]	62	3-5146140-0
71.12[2.800]	73.66[2.900]	58	2-5146140-9
66.04[2.600]	68.58[2.700]	54	2-5146140-8
63.50[2.500]	66.04[2.600]	52	2-5146140-7
58.42[2.300]	60.96[2.400]	48	2-5146140-6
55.88[2.200]	58.42[2.300]	46	2-5146140-5
53.34[2.100]	55.88[2.200]	44	2-5146140-4
50.8[2.000]	53.34[2.100]	42	2-5146140-3
68.58[2.700]	71.12[2.800]	56	2-5146140-2
73.66[2.900]	76.20[3.000]	60	2-5146140-1
60.96[2.400]	63.50[2.500]	50	2-5146140-0
48.26[1.900]	50.8[2.000]	40	1-5146140-9
45.72[1.800]	48.26[1.900]	38	1-5146140-8
43.18[1.700]	45.72[1.800]	36	1-5146140-7
40.64[1.600]	43.18[1.700]	34	1-5146140-6
38.10[1.500]	40.64[1.600]	32	1-5146140-5
35.56[1.400]	38.10[1.500]	30	1-5146140-4
33.02[1.300]	35.56[1.400]	28	1-5146140-3
30.48[1.200]	33.02[1.300]	26	1-5146140-2
27.94[1.100]	30.48[1.200]	24	1-5146140-1
25.40[1.000]	27.94[1.100]	22	1-5146140-0
22.86[.900]	25.40[1.000]	20	5146140-9
17.78[.700]	22.86[.900]	18	5146140-8
17.78[.700]	20.32[.800]	16	5146140-7
15.24[.600]	17.78[.700]	14	5146140-6
12.70[.500]	15.24[.600]	12	5146140-5
10.16[.400]	12.70[.500]	10	5146140-4
7.62[.300]	10.16[.400]	8	5146140-3
5.08[.200]	7.62[.300]	6	5146140-2
2.54[.100]	5.08[.200]	4	5146140-1

THIS DRAWING IS A CONTROLLED DOCUMENT.

DIMENSIONS: mm	TOLERANCES UNLESS OTHERWISE SPECIFIED:	0 PLC ± -	1 PLC ± -	2 PLC ± -	3 PLC ± 0.13[.005]	4 PLC ± -	ANGLES ± -
----------------	--	-----------	-----------	-----------	--------------------	-----------	------------

MATERIAL: 1 2 FINISH: 3

DRN: R BROWN 03JUN02	CHK: J OLSON 03JUN02	APVD: J OLSON 03JUN02	NAME: AMPMODU MOD II RECEPTACLE ASSEMBLY, HORIZONTAL, .100 CL, 2 ROW, CLOSED-ENTRY, SHORT POINT OF CONTACT, END-TO-END STACKABLE
SIZE: A1	SCALE: 5:1	CAGE CODE: 00779	DRAWING NO: 5146140
WEIGHT: -	CUSTOMER DRAWING	SHEET: 1 OF 1	REV: A3

STE TE Connectivity

Mouser Electronics

Authorized Distributor

Click to View Pricing, Inventory, Delivery & Lifecycle Information:

[TE Connectivity:](#)

[1-5146140-9](#)