

REVISIONS				
P	LTR	DESCRIPTION	DATE	APPRO
A2		ADDED 2-2337815-7 PN	23AUG2021	VK GL

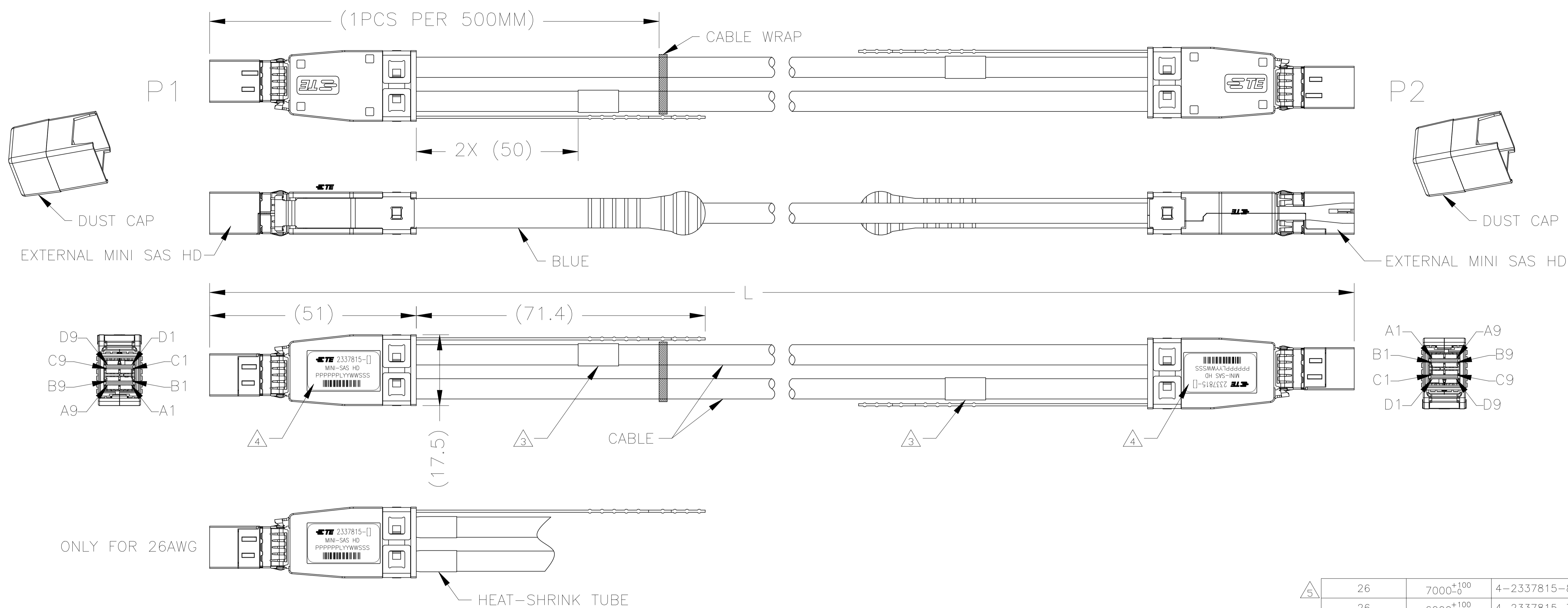

1. ASSEMBLY TESTED FOR CONTINUITY, OPENS, SHORTS, EEPROM PROGRAM AND SIGNAL INTEGRITY.
2. ROHS AND REACH COMPLIANCE: PRODUCT AND PROCESSING MUST MEET REQUIREMENTS OF TE SPECIFICATION TEC-138-702.

3 LABEL INFORMATION:

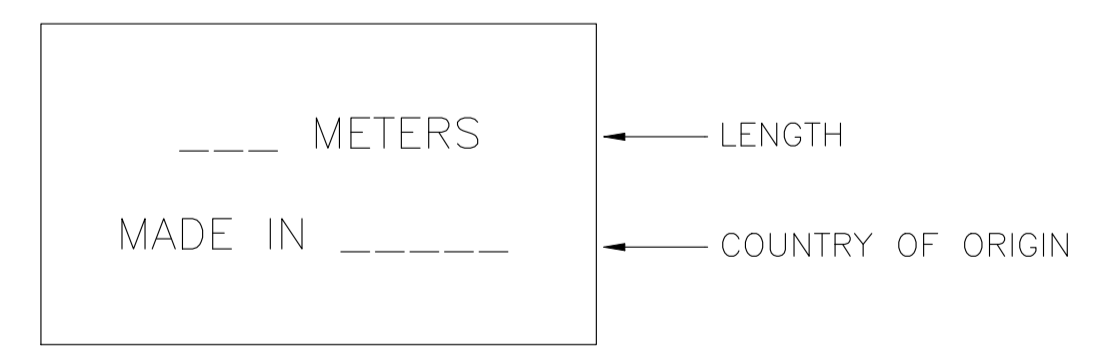

4 LABEL INFORMATION:



5 4-2337815-8 CAN NOT MEET SI SPECIFICATION OF SAS3.0.

AWG	L	PART NO.
26	7000 ⁺¹⁰⁰ ₋₀	4-2337815-8
26	6000 ⁺¹⁰⁰ ₋₀	4-2337815-7
26	5000 ⁺¹⁰⁰ ₋₀	4-2337815-6
26	4000 ⁺⁸⁰ ₋₀	4-2337815-5
26	3000 ⁺⁸⁰ ₋₀	4-2337815-4
26	2000 ⁺⁸⁰ ₋₀	4-2337815-3
26	1000 ⁺⁵⁰ ₋₀	4-2337815-2
26	500 ⁺⁵⁰ ₋₀	4-2337815-1
28	3500 ⁺⁸⁰ ₋₀	2-2337815-7
28	5000 ⁺¹⁰⁰ ₋₀	2-2337815-6
28	4000 ⁺⁸⁰ ₋₀	2-2337815-5
28	3000 ⁺⁸⁰ ₋₀	2-2337815-4
28	2000 ⁺⁸⁰ ₋₀	2-2337815-3
28	1000 ⁺⁵⁰ ₋₀	2-2337815-2
28	500 ⁺⁵⁰ ₋₀	2-2337815-1
30	3000 ⁺⁸⁰ ₋₀	2337815-4
30	2000 ⁺⁸⁰ ₋₀	2337815-3
30	1000 ⁺⁵⁰ ₋₀	2337815-2
30	500 ⁺⁵⁰ ₋₀	2337815-1
AWG	L	PART NO.

THIS DRAWING IS A CONTROLLED DOCUMENT.

DIMENSIONS:	TOLERANCES UNLESS OTHERWISE SPECIFIED:	DIN	05JUN2018	TE Connectivity Ltd.	
mm	0. PLC ± - 1. PLC ± - 2. PLC ± - 3. PLC ± - 4. PLC ± - ANGLES ± -	CHK	05JUN2018		
MATERIAL	FINISH	APPRO	05JUN2018	NAME	
		KYLIN YAO KYLIN YAO DAVID ZHANG		MINI SAS HD TO MINI SAS HD 4X PRODUCT SPEC	
		SIZE	CAGE CODE	DRAWING NO	RESTRICTED TO
		A1	00779	2337815	
		CUSTOMER DRAWING		SCALE	SHEET
				1:1	1 OF 2
				REV	A2

REVISIONS				
P	LTR	DESCRIPTION	DATE	APP'D
-	-	SEE SHEET 1	-	-

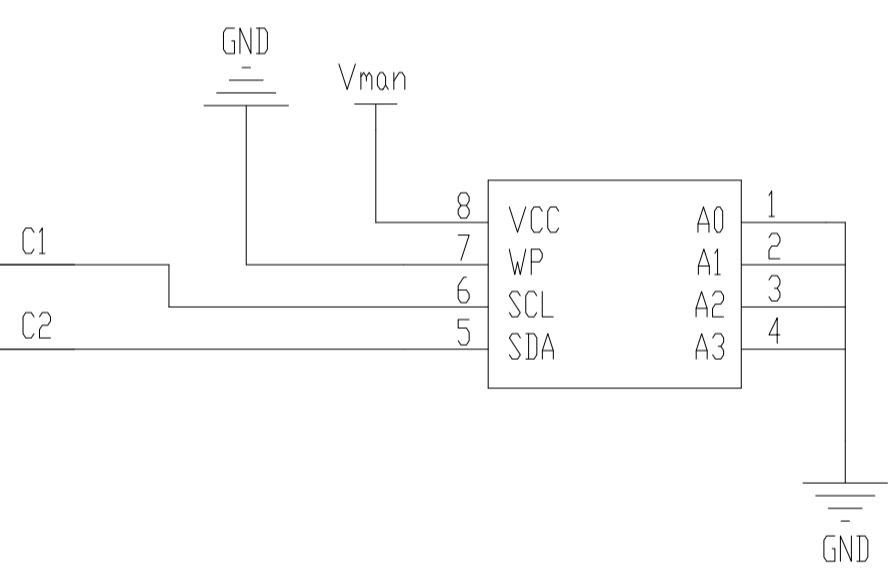
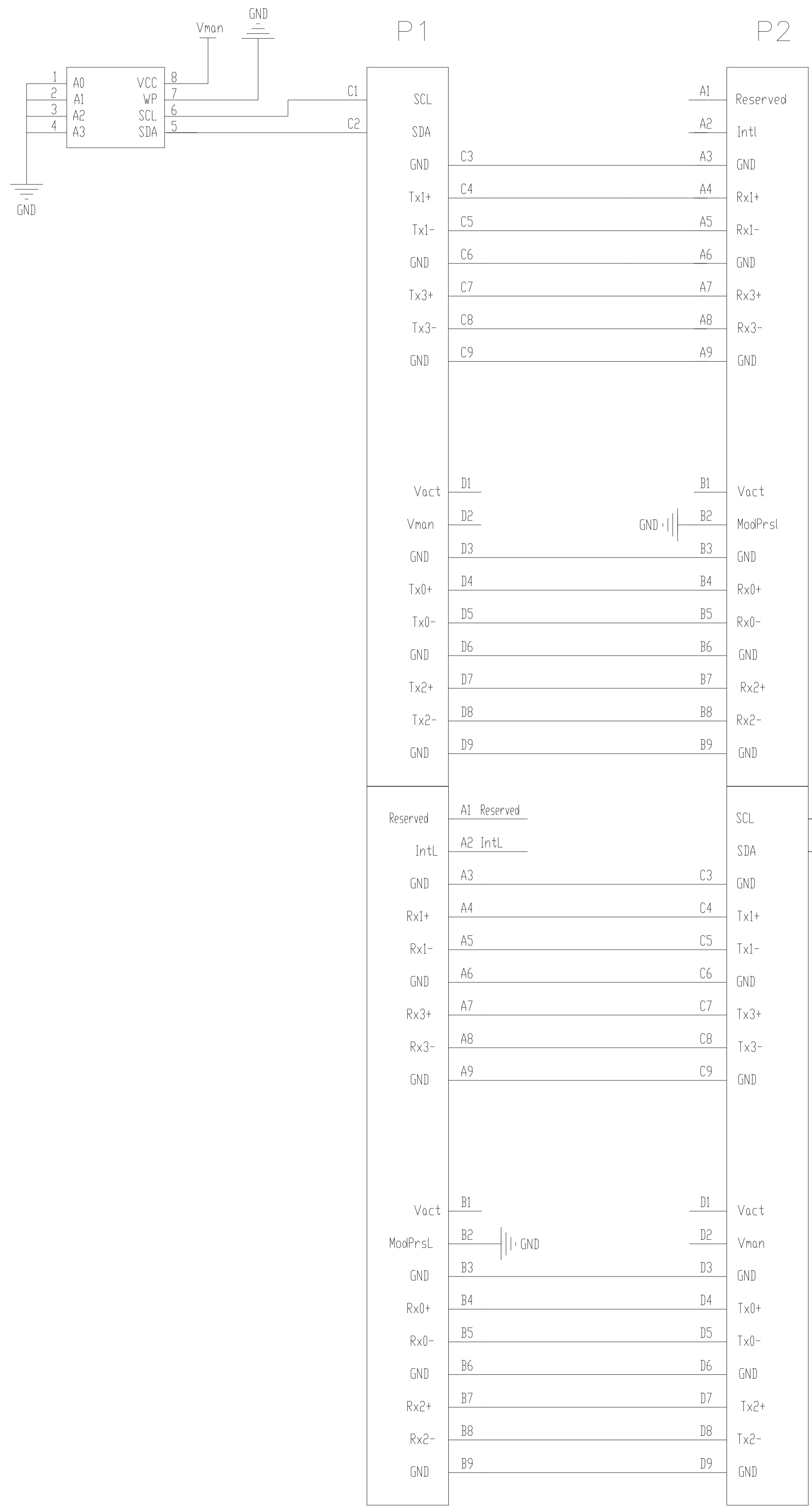

THIS DRAWING IS A CONTROLLED DOCUMENT.		DIN KYLIN YAO 05JUN2018		TE Connectivity Ltd.	
DIMENSIONS: mm		CHK KYLIN YAO 5JUN2018			
TOLERANCES UNLESS OTHERWISE SPECIFIED:		APP'D DAVID ZHANG 5JUN2018		NAME	
0. PLC ± -		PRODUCT SPEC		MINI SAS HD TO MINI SAS HD	
1. PLC ± -		APPLICATION SPEC		4X	
2. PLC ± -		SIZE		A1	
3. PLC ± -		CAGE CODE		00779	
4. PLC ± -		DRAWING NO		C=2337815	
ANGLES ± -		WEIGHT		CUSTOMER DRAWING	
MATERIAL		SCALE		1:1	
FINISH		SHEET		2 of 2	
		REV		A2	

Mouser Electronics

Authorized Distributor

Click to View Pricing, Inventory, Delivery & Lifecycle Information:

[TE Connectivity:](#)

[4-2337815-8](#)