

LOC	DIST	REVISIONS			
P	LTN	DESCRIPTION	DATE	DWN	APVD
A		RELEASED TO PRODUCTION	24MAR2017	JPS	JLM
A1		REVISED PER ECO-19-003870	13MAR2019	AP	PH

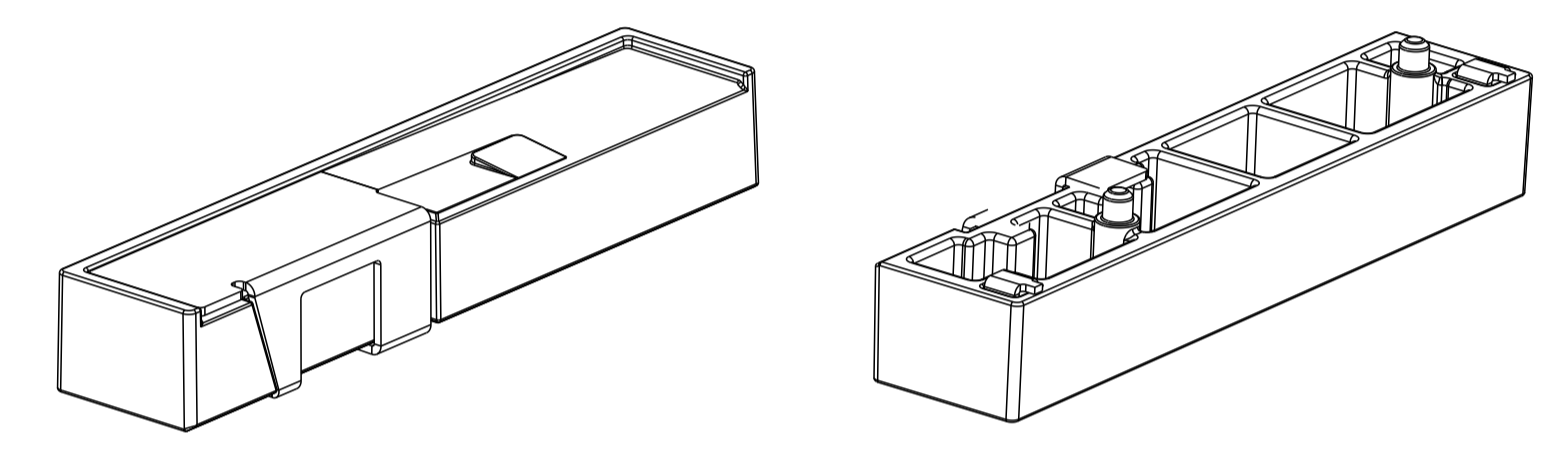

SCALE 4:1

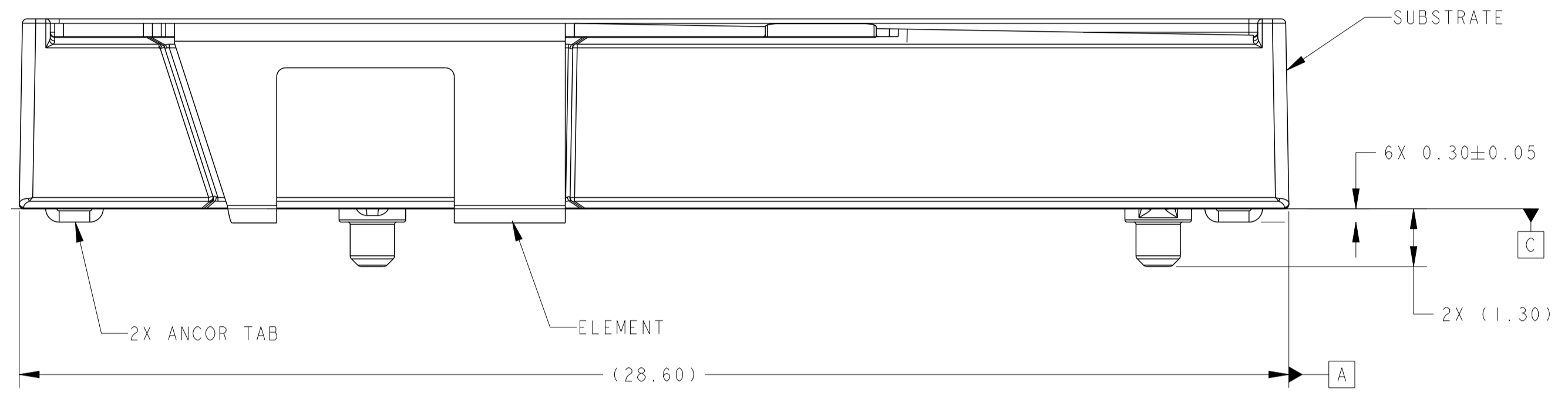
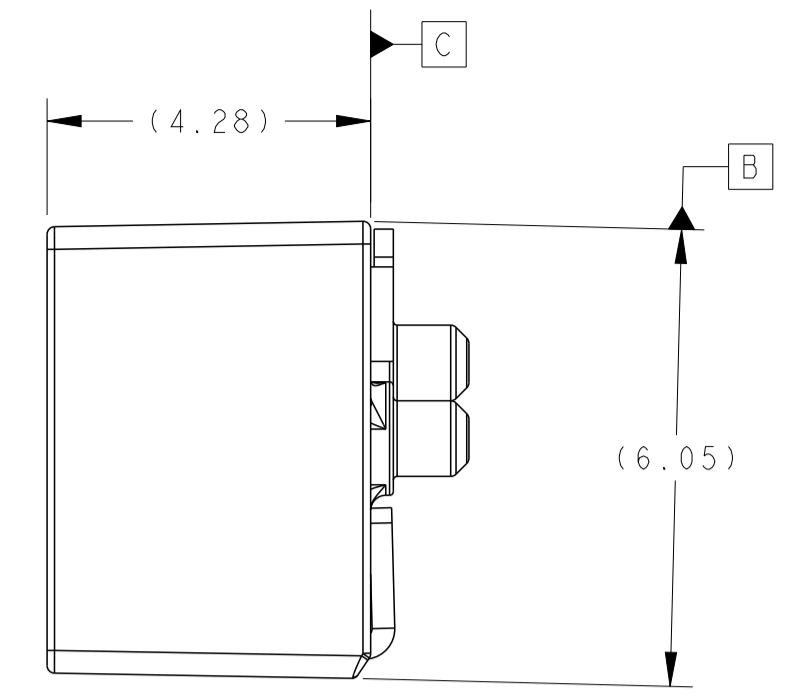
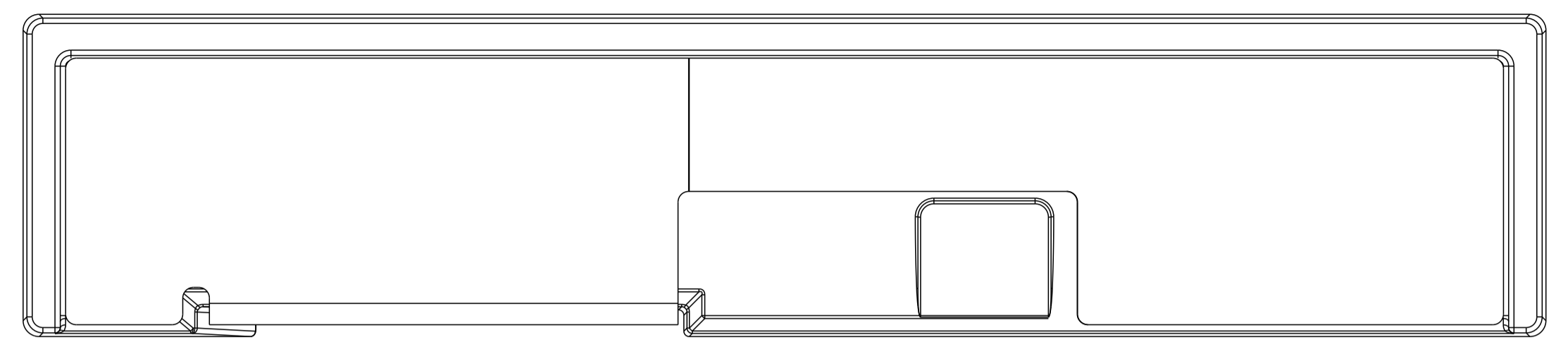
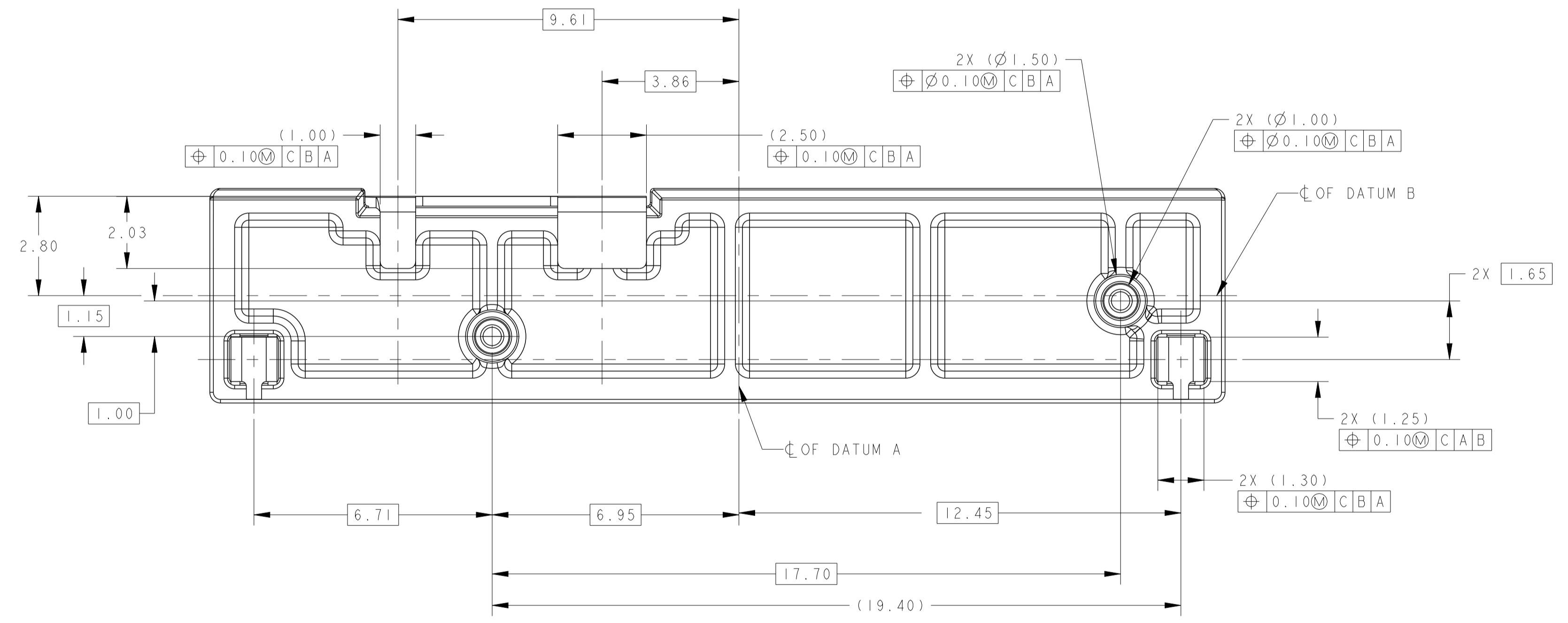

- PRODUCT AND PROCESSING MEETS REQUIREMENTS OF TE CONNECTIVITY ENVIRONMENTAL STANDARD TEC-138-702.
  - MATERIAL:  
 SUBSTRATE: THERMOPLASTIC, BLACK.  
 ELEMENT: COLD ROLLED STEEL.  
 PLATING: TIN OVER NICKEL.
- 3 DIMENSIONS AND DATUMS ESTABLISHED BY CUSTOMER.  
 4 TAPE AND REEL PACKAGING, REFERENCE PACKAGING DETAIL ON SHEET 2.  
 5 TRAY PACKAGING, REFERENCE PACKAGING DETAIL ON SHEET 3.

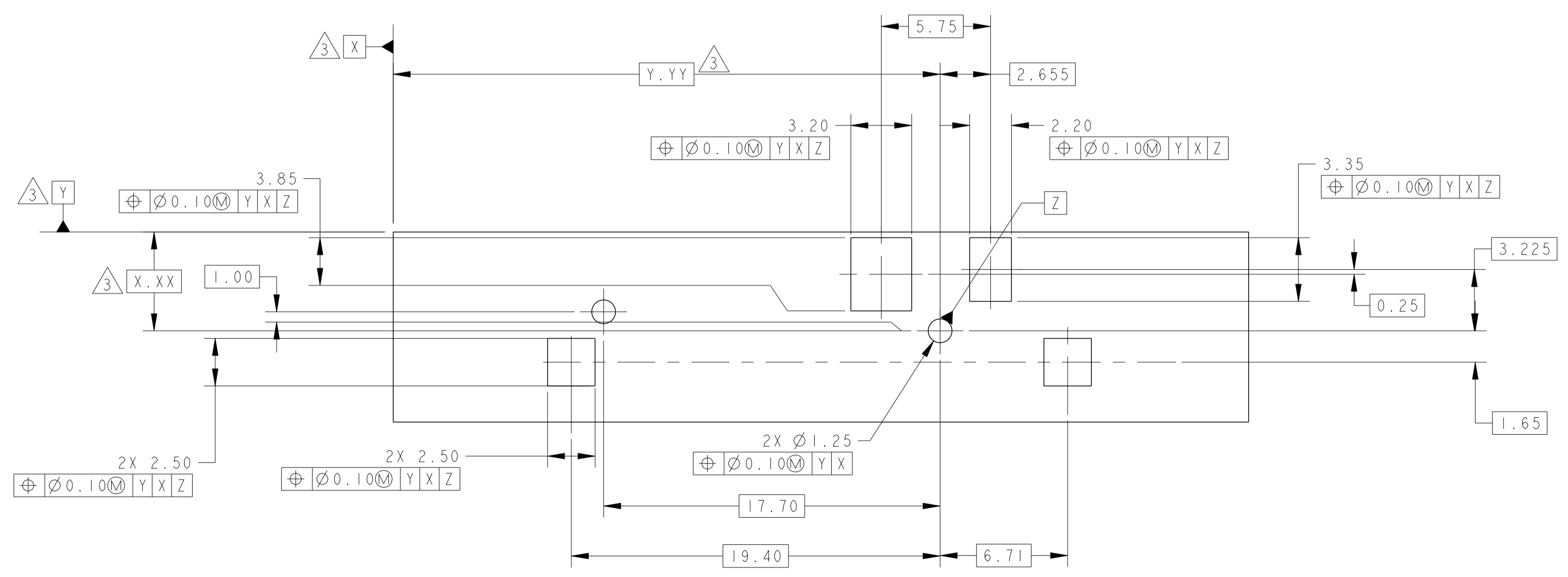

RECOMMENDED PCB LAYOUT  
 SCALE 5:1

5	2118788-2
4	2118788-1
PACKAGING	PART NUMBER

THIS DRAWING IS A CONTROLLED DOCUMENT.

DIMENSIONS:	TOLERANCES UNLESS OTHERWISE SPECIFIED:	DWN J. SCHOLZ 10OCT2016	NAME
mm	0 PLC ±	CHK J. SCHOLZ 10OCT2016	DUAL BAND, WiFi, PIFA 5 GHz, GROUND PLANE DEPENDENT
	1 PLC ±0.10	APVD J. MOORE 10OCT2016	PRODUCT SPEC
	2 PLC ±		APPLICATION SPEC
	3 PLC ±		ANGLE
	4 PLC ±		FINISH
	ANGLES ±1°		WEIGHT
MATERIAL SEE NOTES	FINISH SEE NOTES	CUSTOMER DRAWING	SCALE 10:1 SHEET 1 OF 3 REV A1

SIZE: A100779 C=2118788  
 RESTRICTED TO: -  
 CUSTOMER DRAWING

LOC		DIST		REVISIONS			
P	LTN	DESCRIPTION	DATE	DMN	APVD		
-	-	SEE SHEET 1	-	-	-		

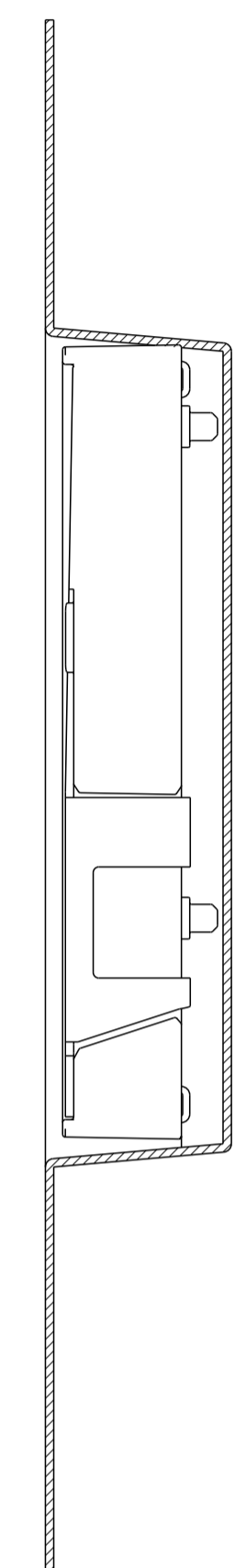
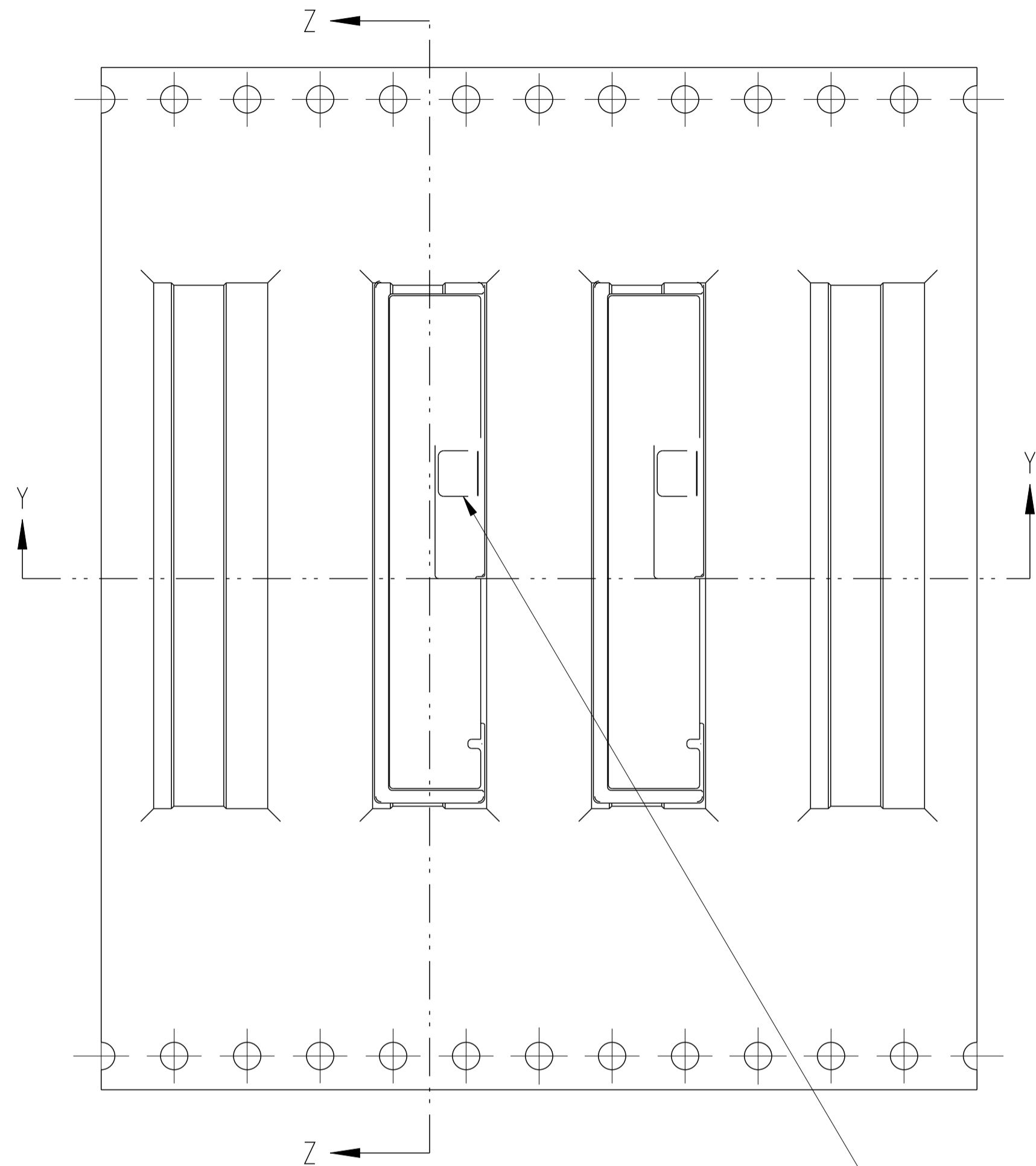

SECTION Z-Z

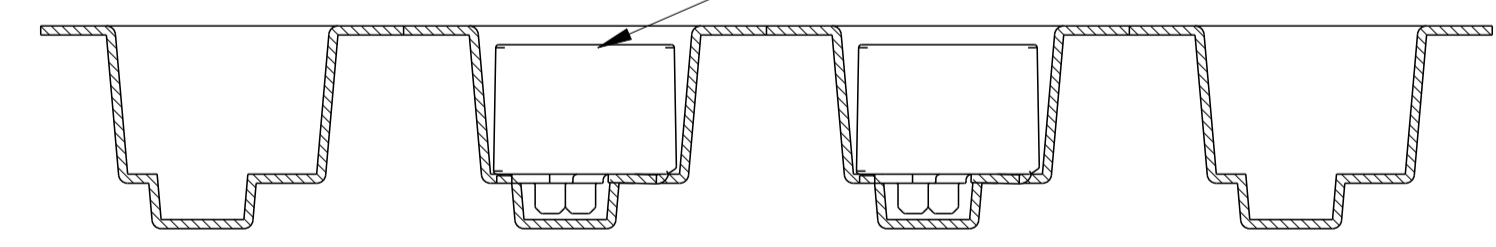

SECTION Y-Y

△ PARTS ORIENTED AS SHOWN.

TAPE AND REEL  
 PACKAGING SHOWN FOR REFERENCE ONLY  
 SEE TEC PN DRAWING 2078292  
 SCALE 4:1

THIS DRAWING IS A CONTROLLED DOCUMENT.		DMN	J. SCHOLZ	10OCT2016	TE Connectivity NAME DUAL BAND, WiFi, PIFA 5 GHz, GROUND PLANE DEPENDENT
DIMENSIONS:		CHK	J. SCHOLZ	10OCT2016	
TOLERANCES UNLESS OTHERWISE SPECIFIED:		APVD	J. MOORE	10OCT2016	
mm 0 PLC ± 1 PLC ± 2 PLC ±0.10 3 PLC ± 4 PLC ± ANGLES ±1°		PRODUCT SPEC			
MATERIAL SEE NOTES		APPLICATION SPEC			SIZE
		FINISH SEE NOTES			CAGE CODE
		WEIGHT			DRAWING NO
		CUSTOMER DRAWING			A100779
		SCALE	10:1	SHEET	2
				OF	3
				REV	A1

LOC	DIST	REVISIONS			
P	LTN	DESCRIPTION	DATE	DMN	APVD
-	-	SEE SHEET 1	-	-	-

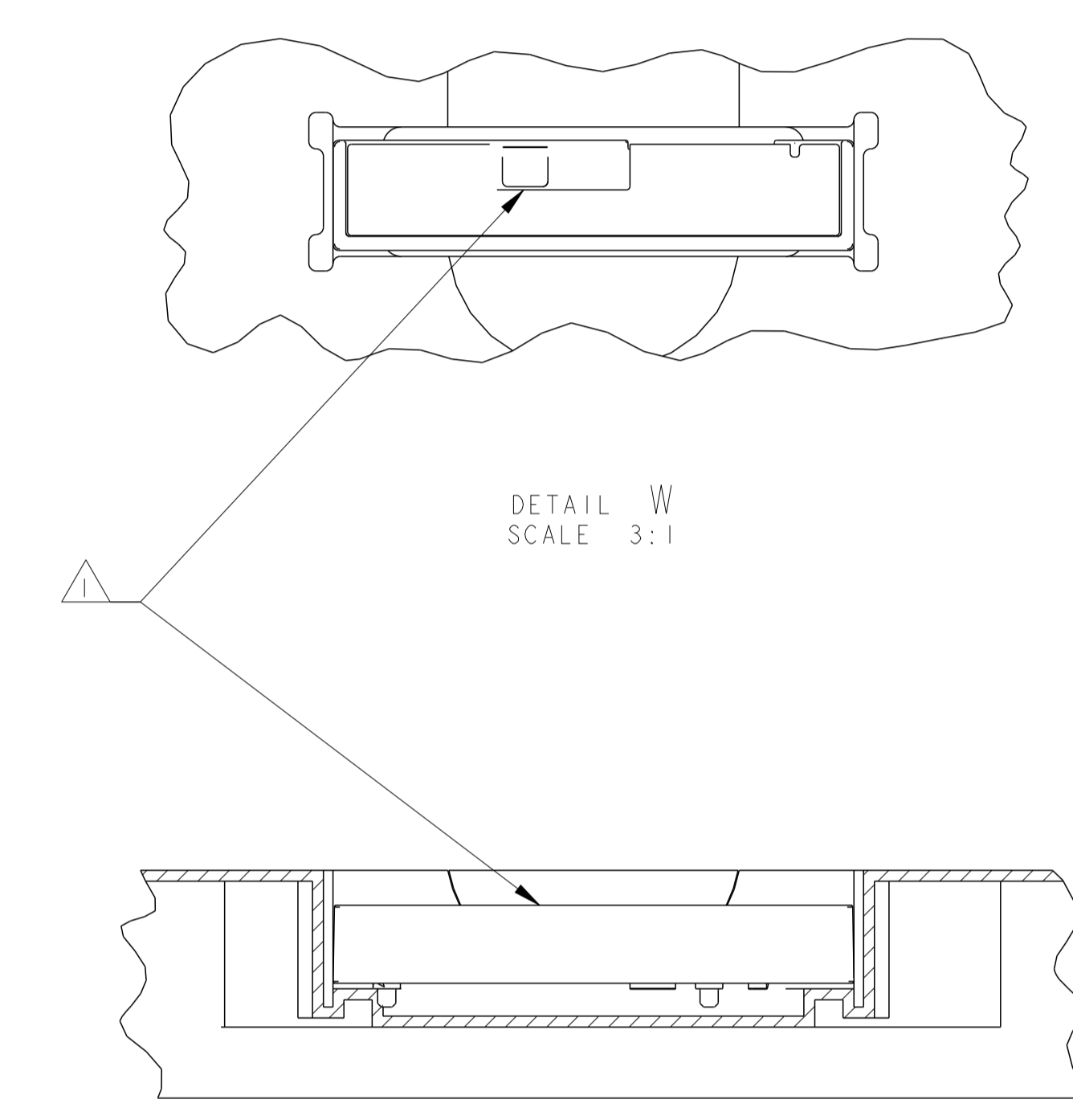
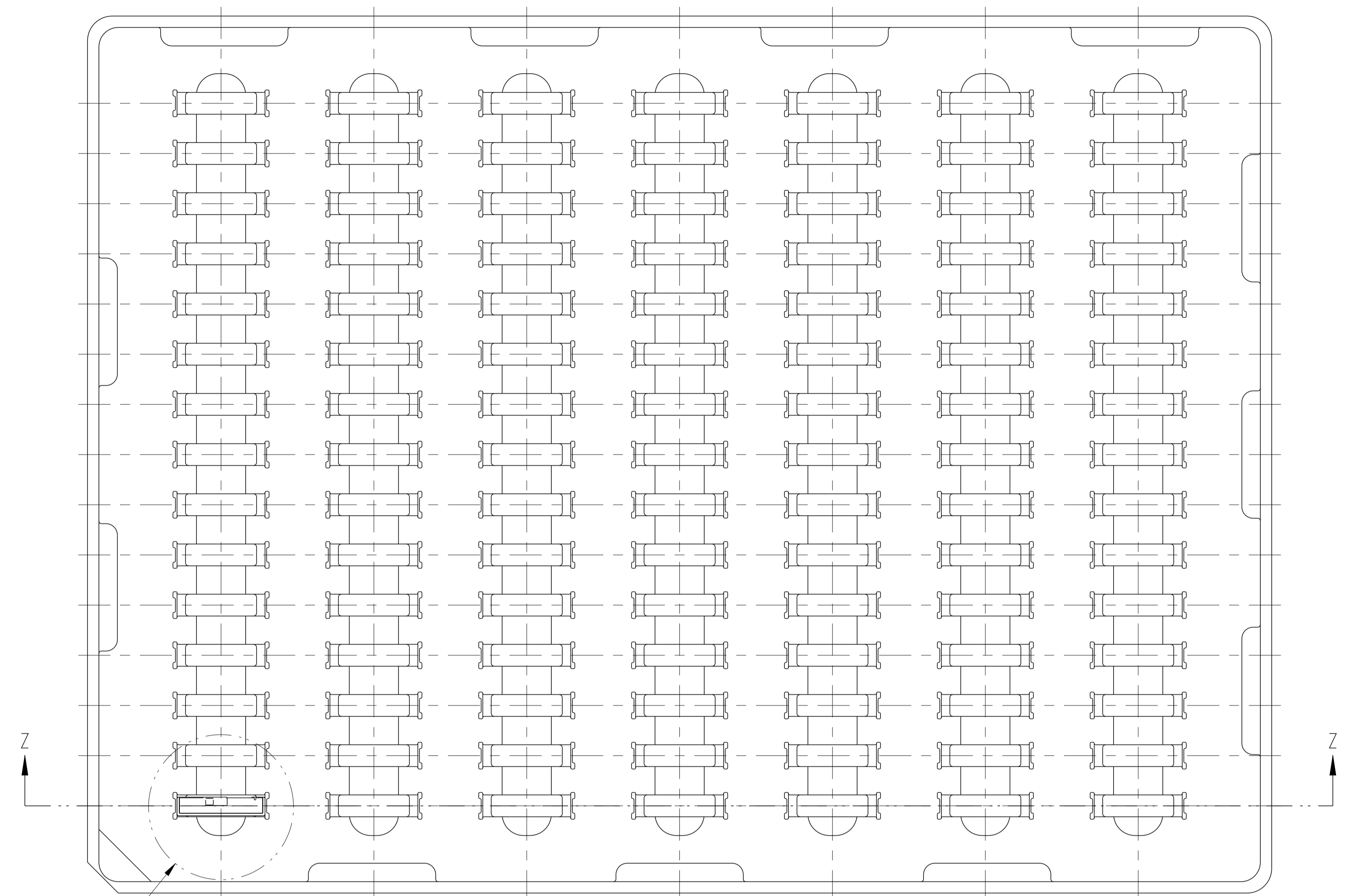

SEE DETAIL W

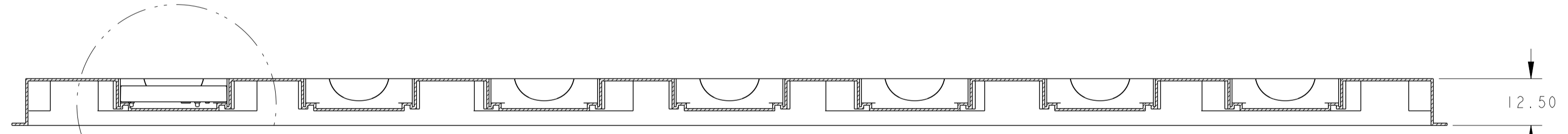

SECTION Z-Z

SEE DETAIL Y

TRAY PACKAGING SHOWN AS REFERENCE ONLY  
 SEE TEC DRAWING 2078293  
 15 PARTS/ROW, 8 ROWS  
 SCALE 1:1

⚠ PARTS ORIENTED AS SHOWN.

THIS DRAWING IS A CONTROLLED DOCUMENT.		DMN J. SCHOLZ 10OCT2016	TE Connectivity DUAL BAND, WiFi, PIFA 5 GHz, GROUND PLANE DEPENDENT
DIMENSIONS:		CHK J. SCHOLZ 10OCT2016	
TOLERANCES UNLESS OTHERWISE SPECIFIED:		APVD J. MOORE 10OCT2016	
mm 0 PLC ± 1 PLC ± 2 PLC ±0.10 3 PLC ± 4 PLC ± ANGLES ±1° FINISH SEE NOTES		NAME PRODUCT SPEC APPLICATION SPEC WEIGHT CUSTOMER DRAWING	
MATERIAL SEE NOTES		SIZE CAGE CODE DRAWING NO A100779C=2118788 SCALE 10:1 SHEET 3 OF 3 REV A1	RESTRICTED TO

# Mouser Electronics

Authorized Distributor

Click to View Pricing, Inventory, Delivery & Lifecycle Information:

[TE Connectivity:](#)

[2118788-2](#)