

LOC		DIST		REVISIONS			
P	LTN	DESCRIPTION	DATE	DWN	APVD		
A		RELEASED TO PRODUCTION	24MAR2017	JPS	JLM		
A1		REVISED PER ECO-19-003870	13MAR2019	AP	PH		

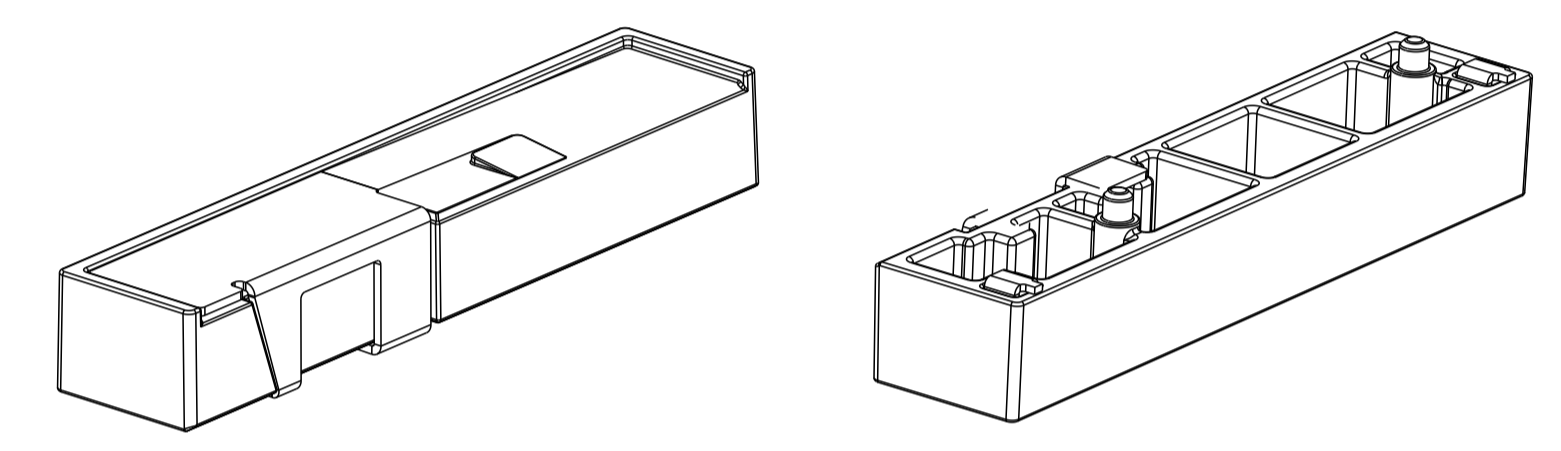

SCALE 4:1

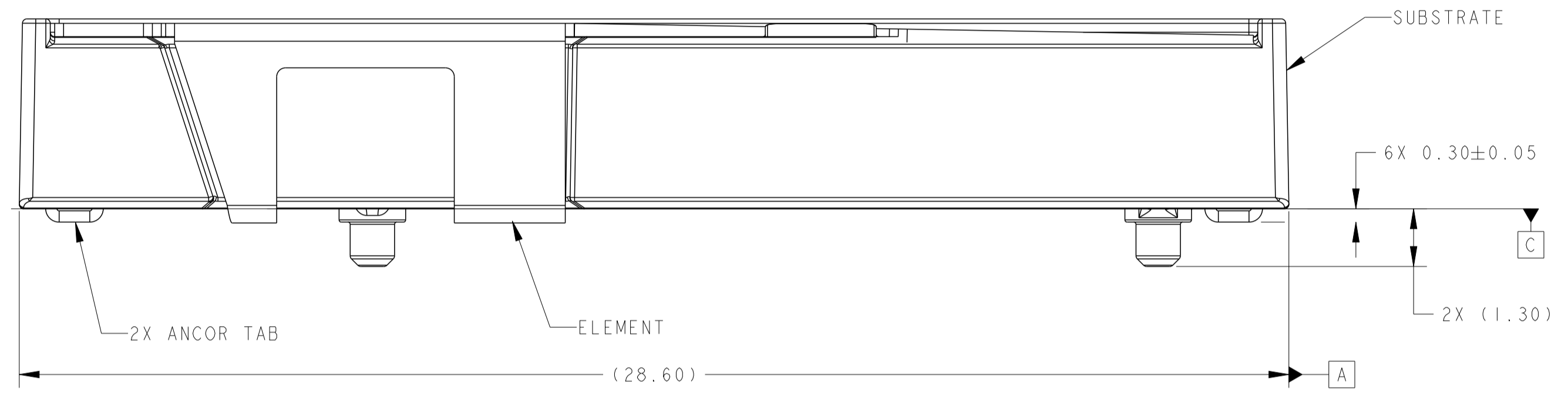
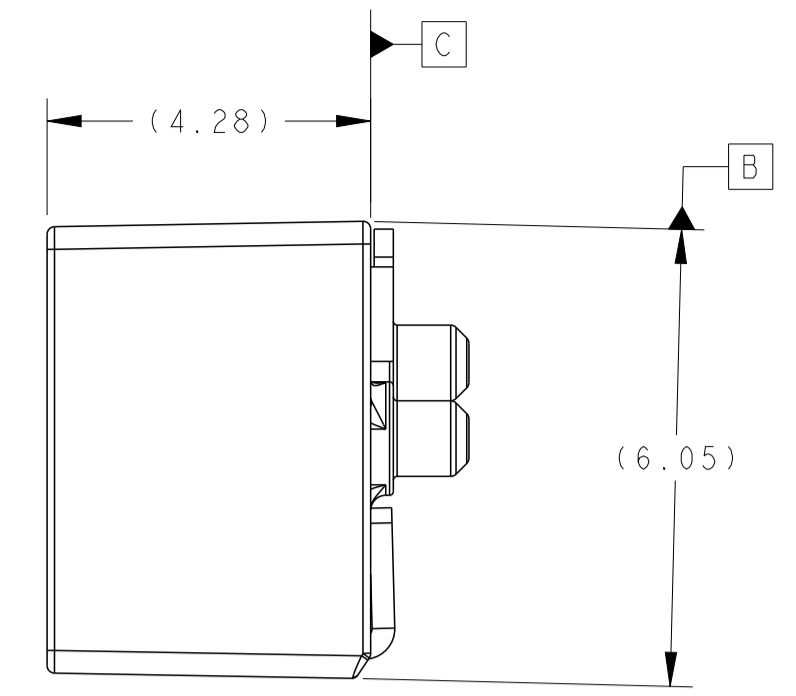
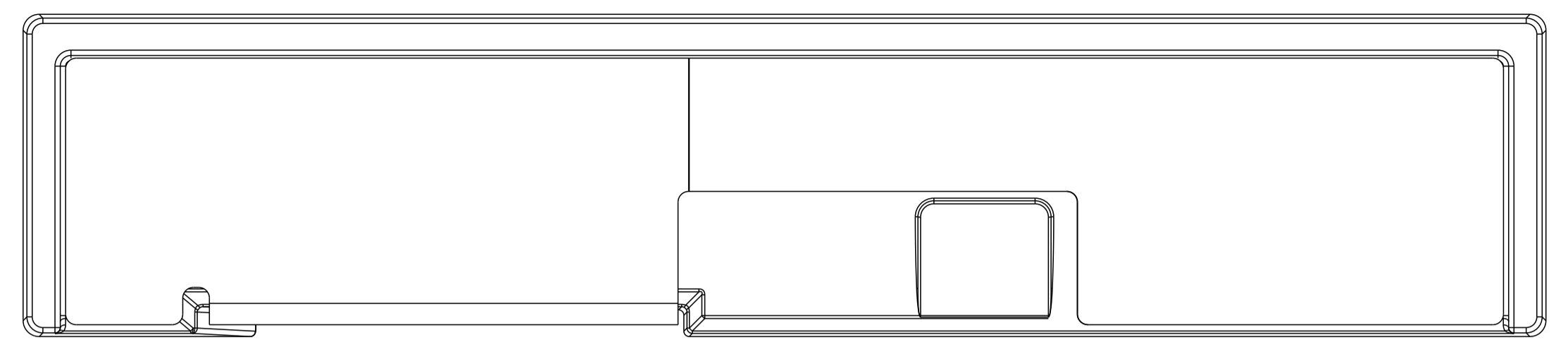
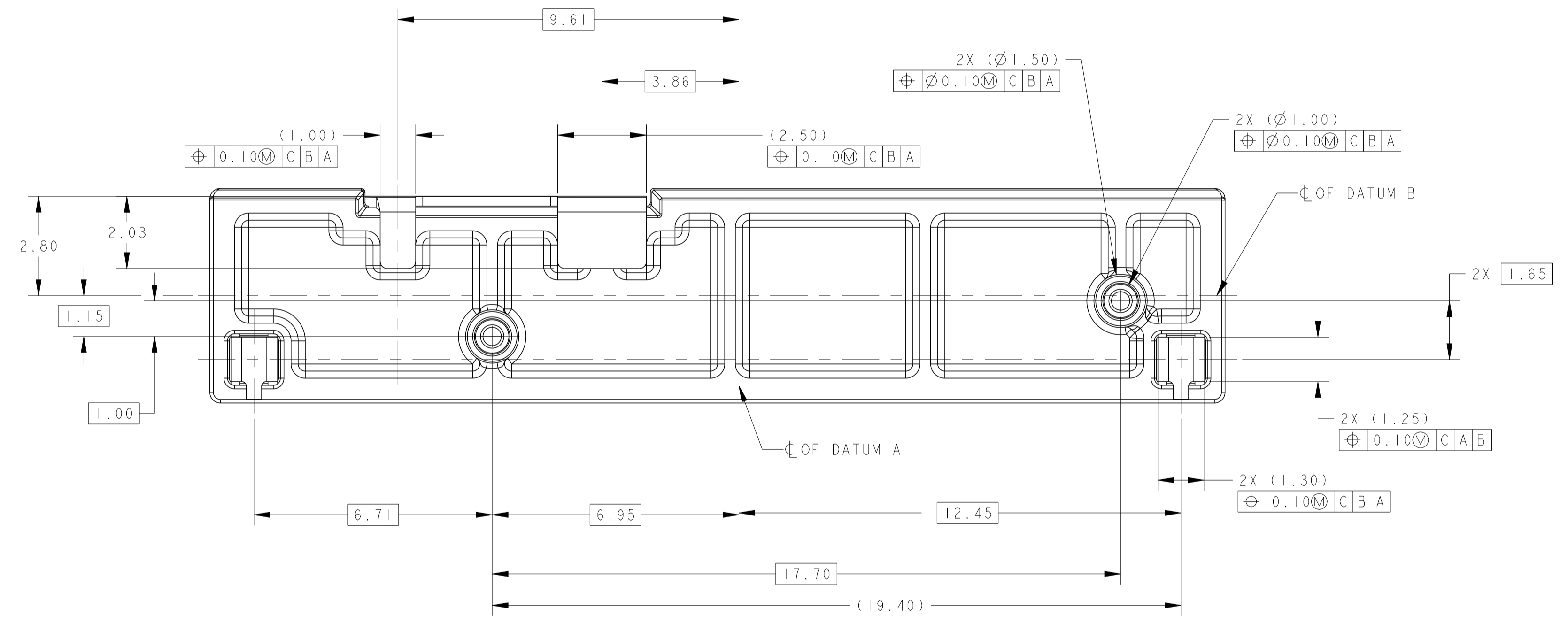

- PRODUCT AND PROCESSING MEETS REQUIREMENTS OF TE CONNECTIVITY ENVIRONMENTAL STANDARD TEC-138-702.
 - MATERIAL:
 SUBSTRATE: THERMOPLASTIC, BLACK.
 ELEMENT: COLD ROLLED STEEL.
 PLATING: TIN OVER NICKEL.
- 3 DIMENSIONS AND DATUMS ESTABLISHED BY CUSTOMER.
 4 TAPE AND REEL PACKAGING, REFERENCE PACKAGING DETAIL ON SHEET 2.
 5 TRAY PACKAGING, REFERENCE PACKAGING DETAIL ON SHEET 3.

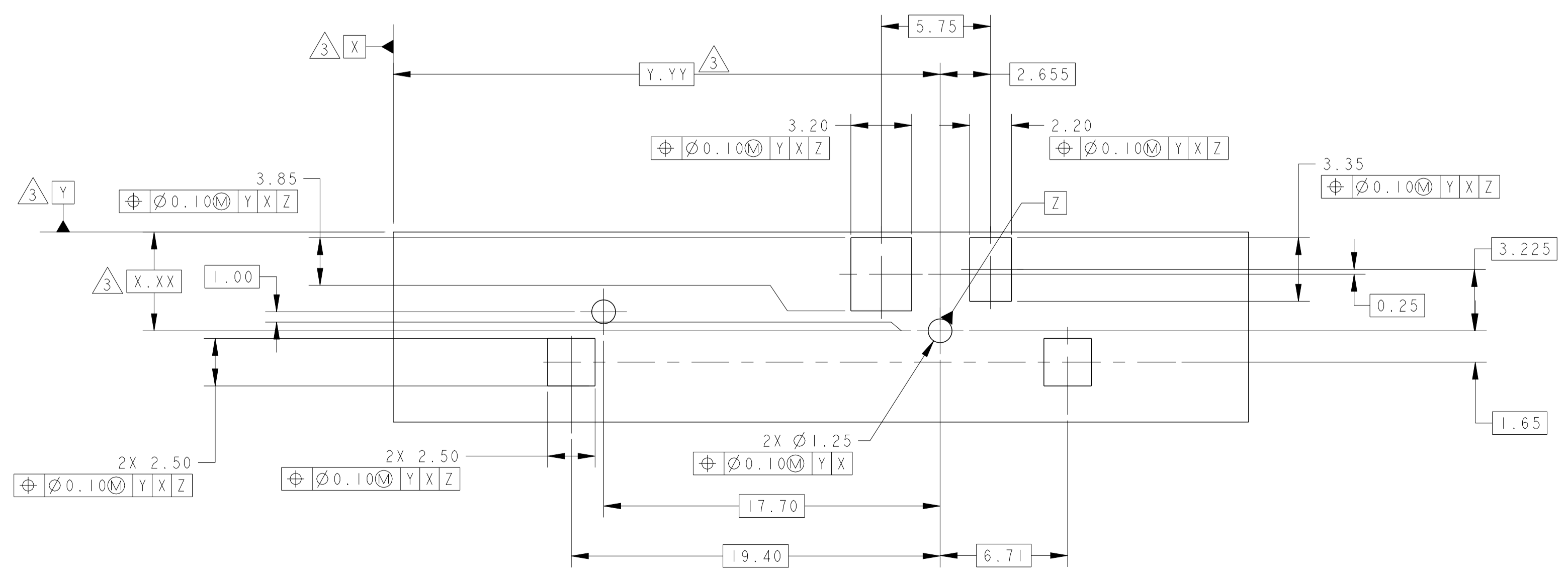

RECOMMENDED PCB LAYOUT
 SCALE 5:1

5	2118788-2
4	2118788-1
PACKAGING	PART NUMBER

THIS DRAWING IS A CONTROLLED DOCUMENT.

DIMENSIONS:	TOLERANCES UNLESS OTHERWISE SPECIFIED:	DWN J. SCHOLZ 10OCT2016	NAME
mm	0 PLC ±	CHK J. SCHOLZ 10OCT2016	DUAL BAND, WiFi, PIFA 5 GHz, GROUND PLANE DEPENDENT
	1 PLC ±0.10	APVD J. MOORE 10OCT2016	SIZE CAGE CODE DRAWING NO
	2 PLC ±	PRODUCT SPEC	RESTRICTED TO
	3 PLC ±	APPLICATION SPEC	A100779C=2118788
	4 PLC ±	WEIGHT	SCALE 10:1 SHEET 1 OF 3 REV A1
	ANGLES ±1°	CUSTOMER DRAWING	
MATERIAL SEE NOTES	FINISH SEE NOTES		

LOC		DIST		REVISIONS			
P	LTN	DESCRIPTION	DATE	DMN	APVD		
-	-	SEE SHEET 1	-	-	-		

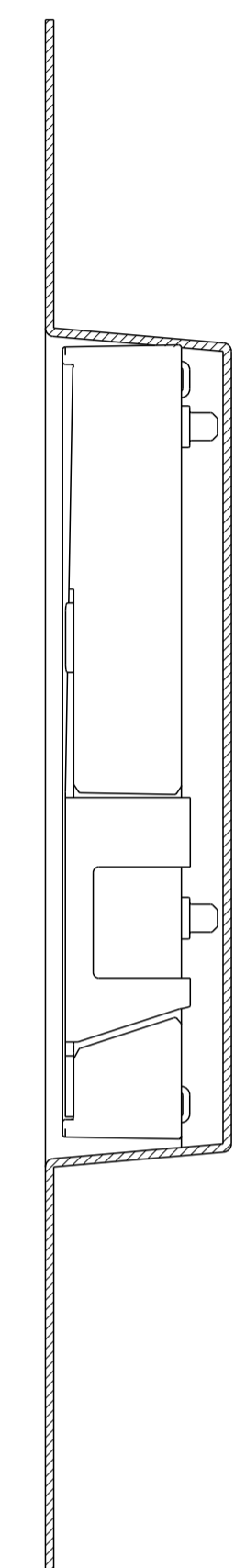
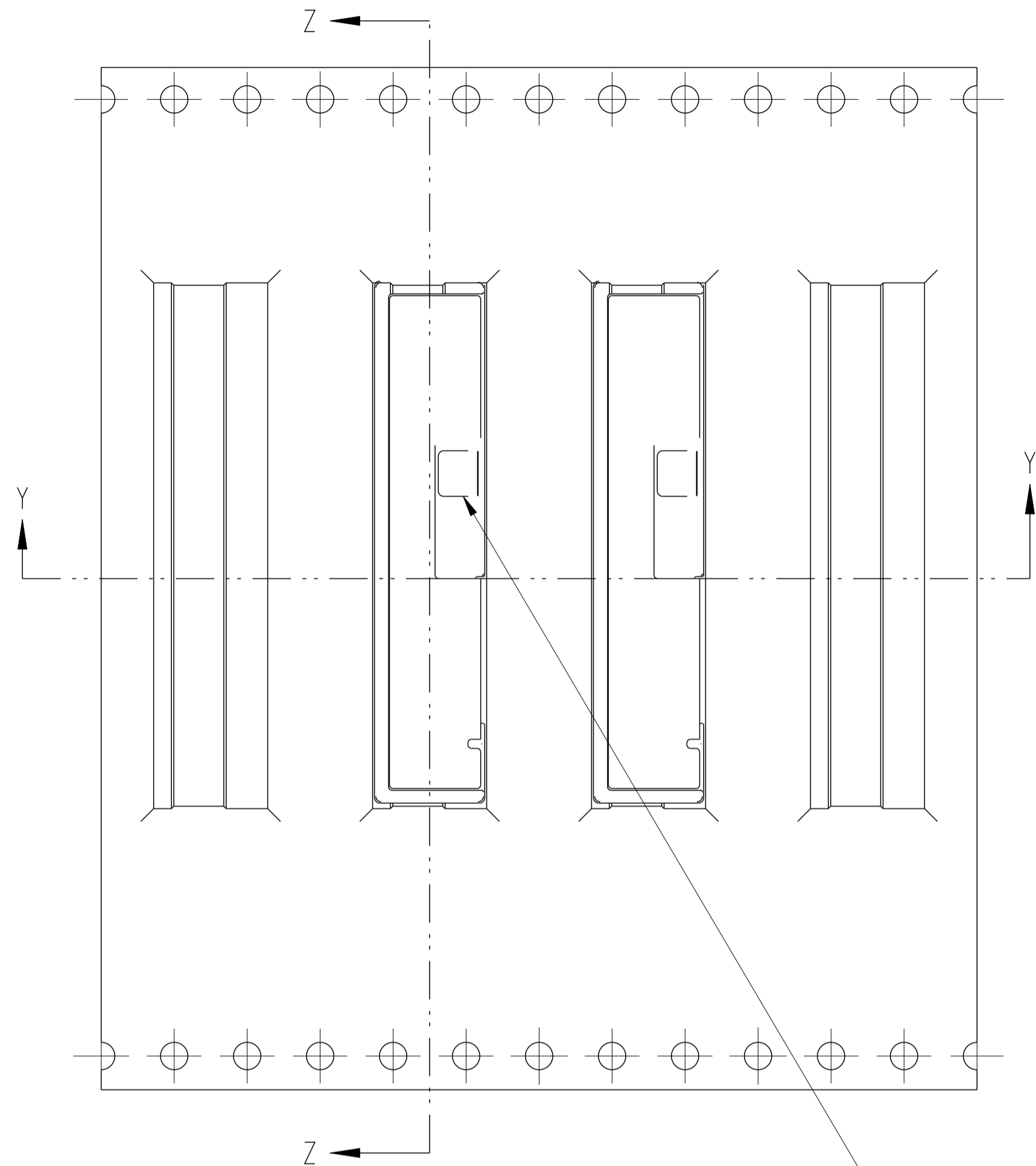

SECTION Z-Z

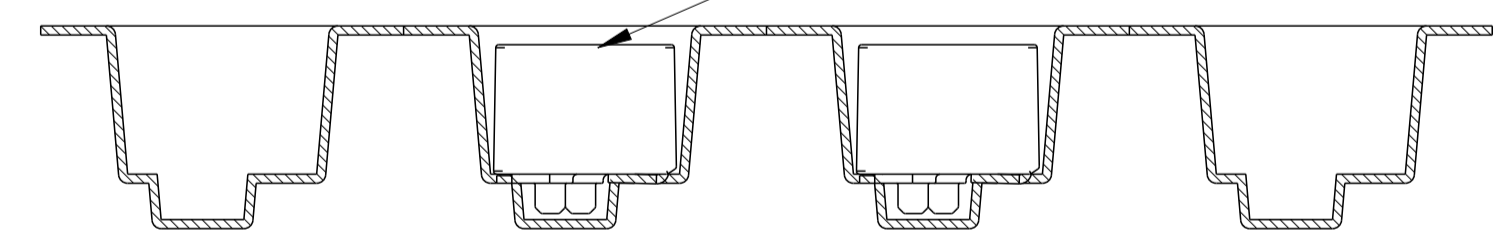

SECTION Y-Y

△ PARTS ORIENTED AS SHOWN.

TAPE AND REEL
 PACKAGING SHOWN FOR REFERENCE ONLY
 SEE TEC PN DRAWING 2078292
 SCALE 4:1

THIS DRAWING IS A CONTROLLED DOCUMENT.		DMN	J. SCHOLZ	10OCT2016	 TE Connectivity	NAME DUAL BAND, WiFi, PIFA 5 GHz, GROUND PLANE DEPENDENT		
DIMENSIONS:		CHK	J. SCHOLZ	10OCT2016				
TOLERANCES UNLESS OTHERWISE SPECIFIED:		APVD	J. MOORE	10OCT2016				
mm		PRODUCT SPEC						
0 PLC	±	APPLICATION SPEC			SIZE	CAGE CODE	DRAWING NO	RESTRICTED TO
1 PLC	±				A1	00779	C=2118788	
2 PLC	±0.10							
3 PLC	±							
4 PLC	±							
ANGLES	±1°							
MATERIAL SEE NOTES		FINISH	SEE NOTES		WEIGHT	-		
					CUSTOMER DRAWING		SCALE	10:1
							SHEET	2 OF 3
							REV	A1

LOC	DIST	REVISIONS			
P	LTN	DESCRIPTION	DATE	DMN	APVD
-	-	SEE SHEET 1	-	-	-

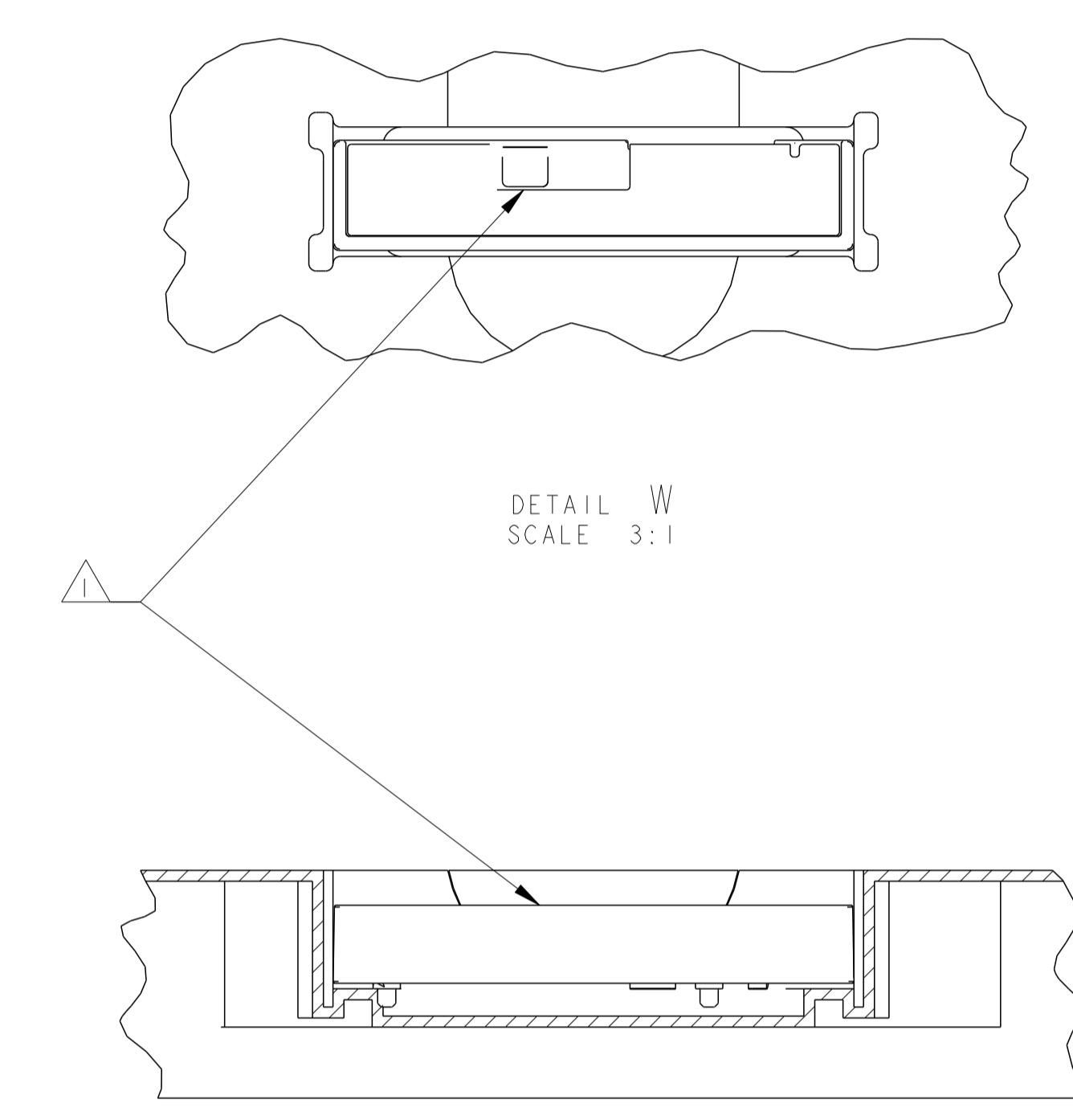
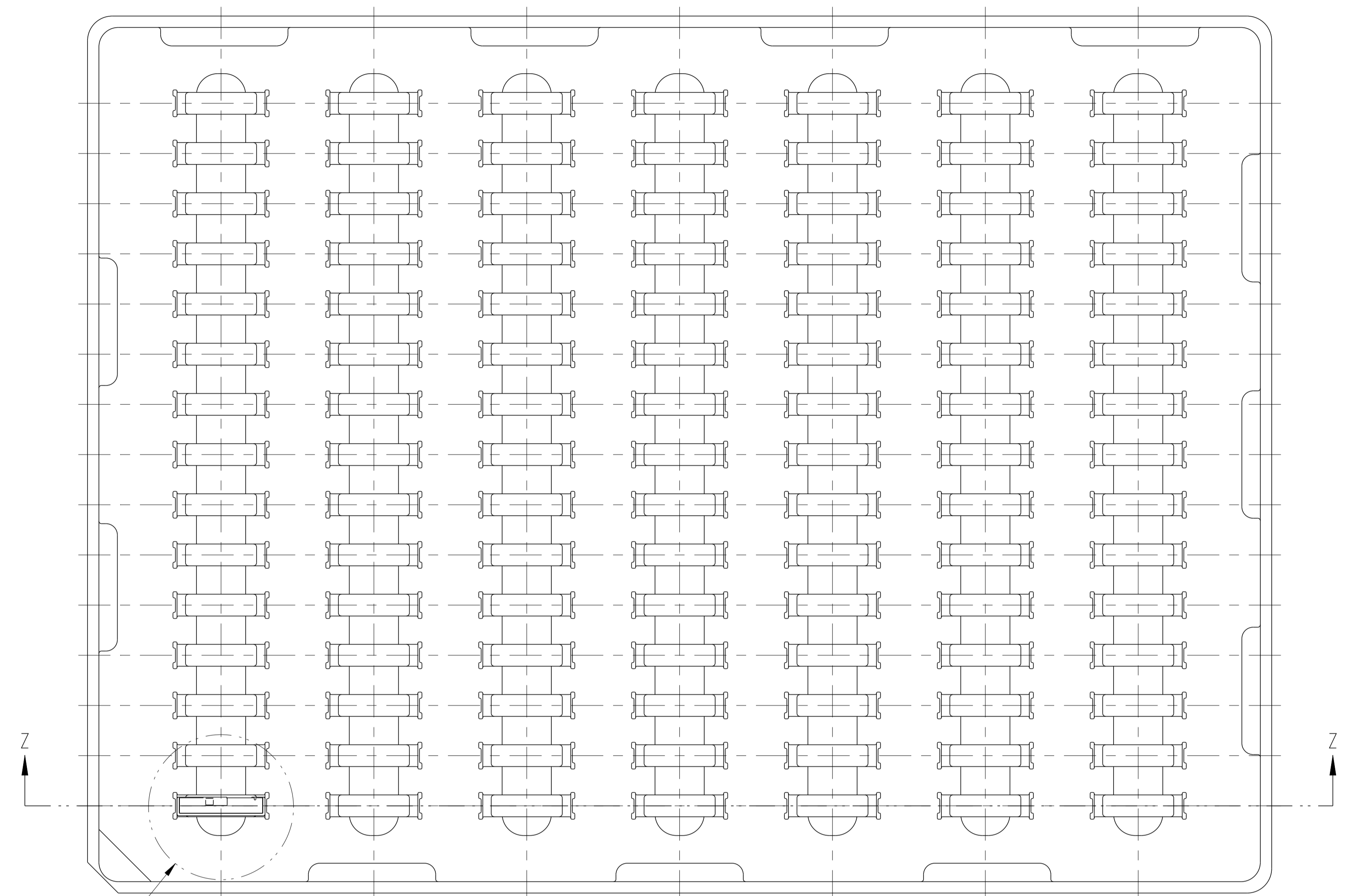

SEE DETAIL W

SEE DETAIL Y

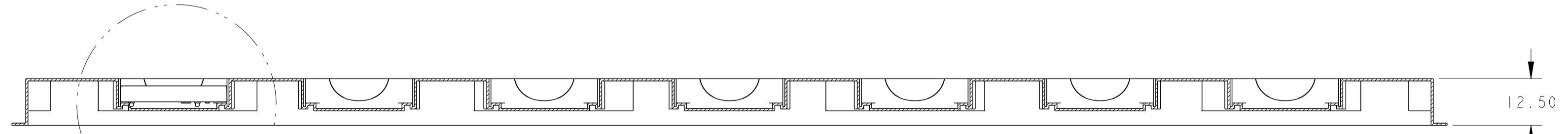

SECTION Z-Z

TRAY PACKAGING SHOWN AS REFERENCE ONLY
 SEE TEC DRAWING 2078293
 15 PARTS/ROW, 8 ROWS
 SCALE 1:1

▲ PARTS ORIENTED AS SHOWN.

THIS DRAWING IS A CONTROLLED DOCUMENT.		DMN J. SCHOLZ 10OCT2016	TE Connectivity DUAL BAND, WiFi, PIFA 5 GHz, GROUND PLANE DEPENDENT
DIMENSIONS:		CHK J. SCHOLZ 10OCT2016	
TOLERANCES UNLESS OTHERWISE SPECIFIED:		APVD J. MOORE 10OCT2016	
mm 0 PLC ± 1 PLC ± 2 PLC ±0.10 3 PLC ± 4 PLC ± ANGLES ±1° FINISH SEE NOTES		NAME PRODUCT SPEC APPLICATION SPEC WEIGHT CUSTOMER DRAWING	
MATERIAL SEE NOTES		SIZE CAGE CODE DRAWING NO A100779C=2118788	RESTRICTED TO
		SCALE 10:1	SHEET 3 OF 3
		REV A1	

Mouser Electronics

Authorized Distributor

Click to View Pricing, Inventory, Delivery & Lifecycle Information:

[TE Connectivity:](#)

[2118788-1](#)