

© 2021 TE Connectivity. All Rights Reserved.

MATED WITH:  
PASSEND ZU:  
SEE NOTE 9

PROJEKT NR.:  
EGATN09123

REVISIONS  
ÄNDERUNGEN

P	LTR	DESCRIPTION BESCHREIBUNG	DATE	DWN	APVD
A1		PART REWORKED	18SEP2009	VD	Ch E
A2		DRAWING REWORKED	04FEB2010	NP	Ch E
A3		NEW VERSION ADDED SEE PCN: E-10-020863	08OCT2010	NP	Ch E
A4		NEW VERSION ADDED	27JAN2021	NP	AW

1-2112045-1 AS SHOWN  
1-2112045-1 wie gezeigt

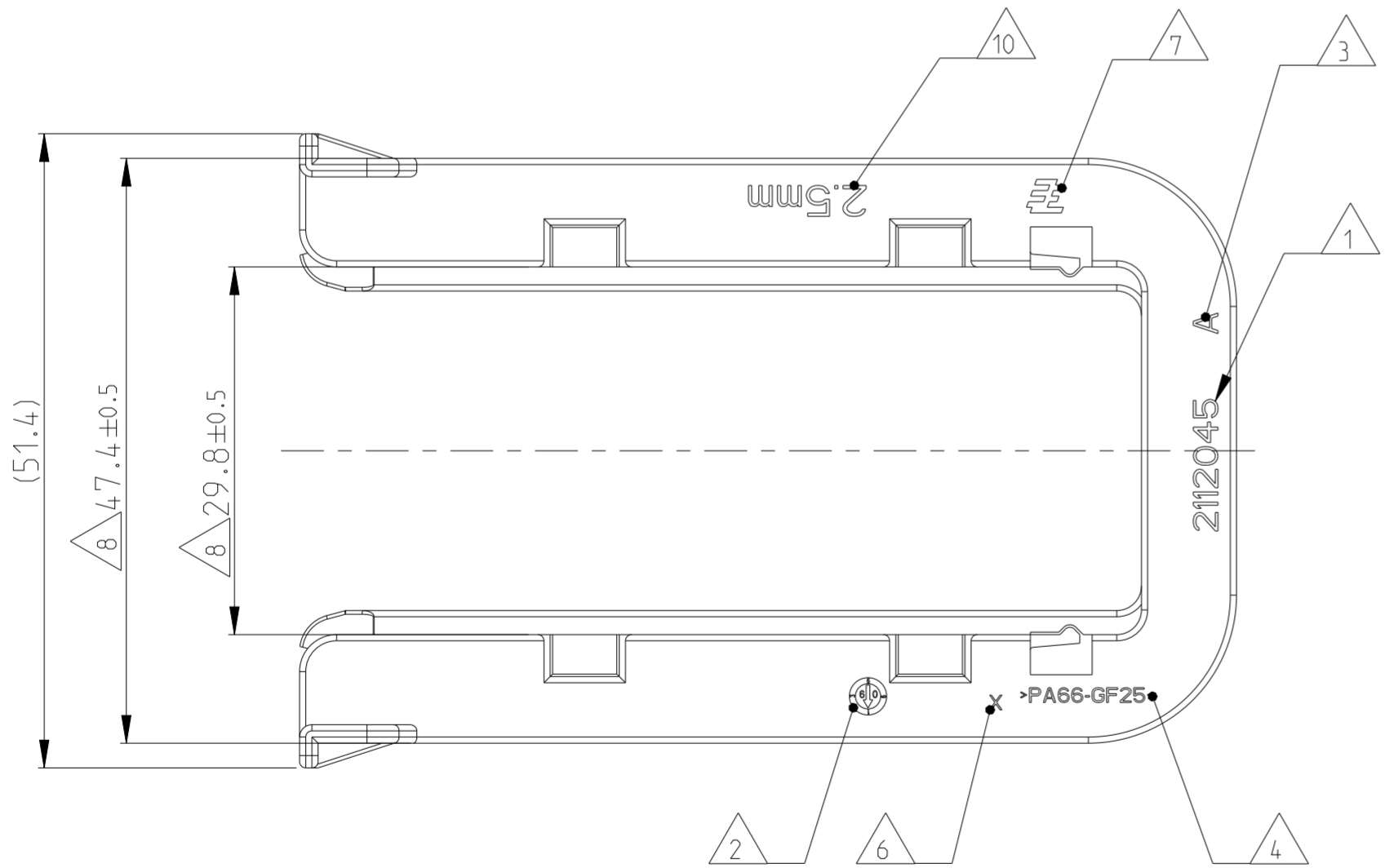
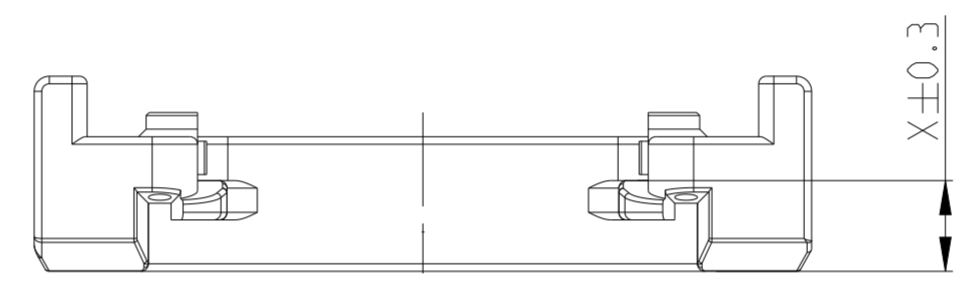
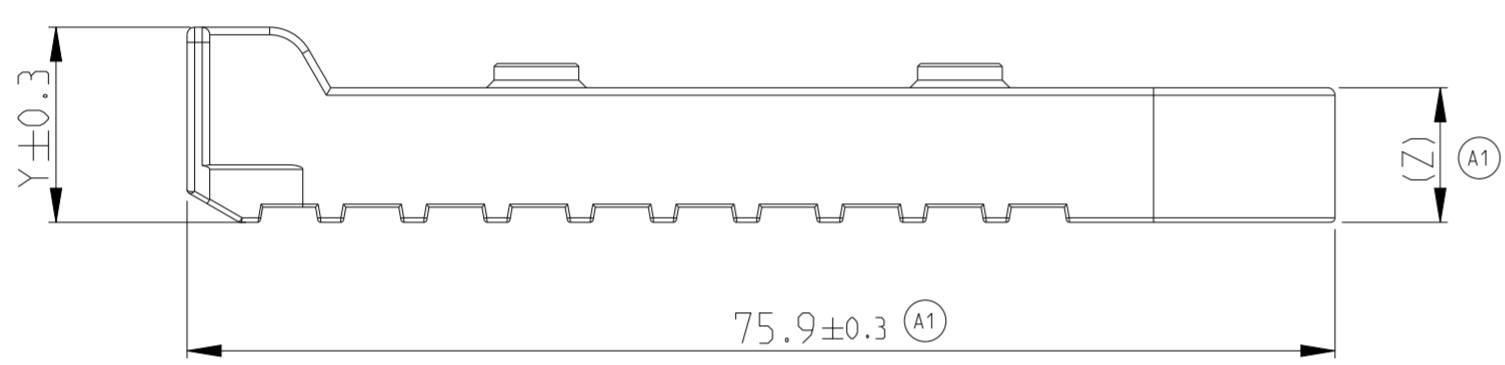
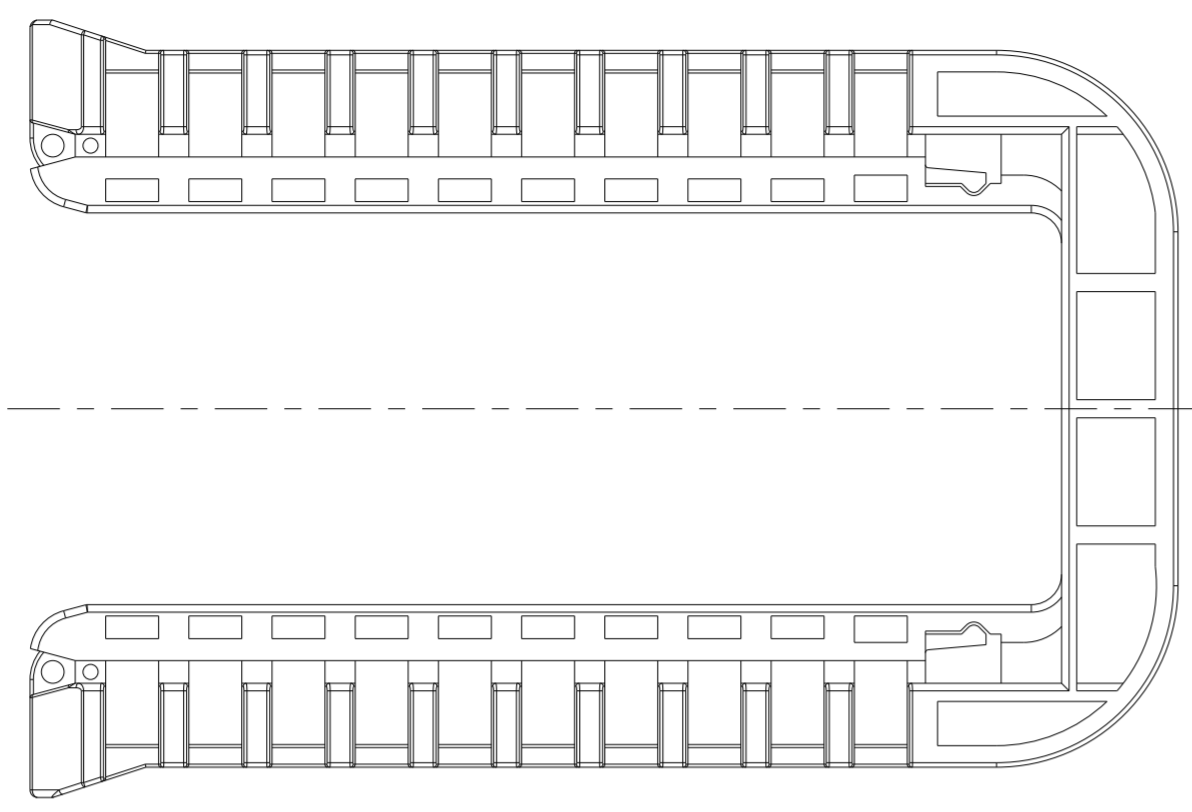

NOTES

Bemerkungen

- 1 TE ORDER-NO.  
TE Bestell-Nr.
- 2 PRODUCTION DATE  
Produktionsdatum
- 3 LETTER-INSERT FOR THE REVISION STATUS OF THE MOULD  
Schriftsatz fuer Aenderungszustand des Werkzeuges
- 4 MATERIAL MARKING ACCORDING TO VDA 260  
Werkstoffkennzeichnung nach VDA 260
- 5 BULK PACKAGING IN CORRUGATED BOX  
Schuettgut im Versandkarton
- 6 MOULD CAVITY MARKING  
Nestmarkierung
- 7 TE LOGO  
TE Logo
- 8 WARPAGE PERMITTED UP TO -2mm FROM NOMINAL SIZE  
Verzug zulaessig bis -2mm vom Nennmass
- 9 SUITABLE FOR TAB HOUSING WITH FLANGE  
SEE 2112041  
Passend zu Flachsteckergehaeusen mit Flansch  
siehe 2112041
- 10 MARKING FOR SUITABLE SHEET METAL THICKNESS (NOMINAL SIZE)  
Kennzeichnung fuer passende Blechstaerke (Nennmass)

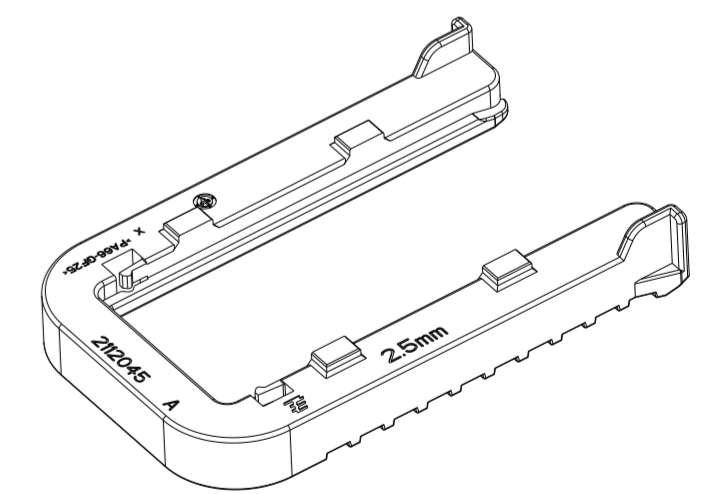

1:1

TE ORDER-NO. TE Bestell-Nr.	REV.	SHEET METAL THICKNESS Blechdicke	DIM X	DIM Y	DIM Z	MAT.	COLOUR Farbe	DESCRIPTION Beschreibung	ITEM
-	-	-	-	-	-	-	-	SLIDE, FOR 1.5mm SHEET METAL Schieber, fuer Blech 1.5mm Dicke	6
-	-	-	-	-	-	-	-	SLIDE, FOR 1mm SHEET METAL Schieber, fuer Blech 1mm Dicke	5
-	-	-	-	-	-	-	-	SLIDE, FOR 4mm SHEET METAL Schieber, fuer Blech 4mm Dicke	4
2112045-3	A	3.5 ± 0.1mm	5	11.9	7.9	PA66-GF25/V-0	GREY grau	SLIDE, FOR 3.5mm SHEET METAL Schieber, fuer Blech 3.5mm Dicke	3
2112045-2	A	3 ± 0.1mm	5.5	12.4	8.4	PA66-GF25/V-0	YELLOW gelb	SLIDE, FOR 3mm SHEET METAL Schieber, fuer Blech 3mm Dicke	2
2112045-1	A	2.5 ± 0.1mm	6.1	13	8.9	PA66-GF25/V-0	RED rot	SLIDE, FOR 2.5mm SHEET METAL Schieber, fuer Blech 2.5mm Dicke	1

THIS DRAWING IS A CONTROLLED DOCUMENT.  
DIESES ZEICHNUNGSDOKUMENT WIRD DURCH AMP INCORPORATED KONTROLLIERT.  
ÄNDERUNGEN, DIE DEM TECHNISCHEN FORTSCHRITT GÜNTIG SIND, VORBEHALTEN.  
DEN JEWEILS LETZTIGELTEN ÄNDERUNGSSTAND ERFAHREN SIE AUF ANFRAGE.

DIMENSIONS: MASSEINHEITEN: mm	TOLERANCES UNLESS OTHERWISE SPECIFIED: ACC. TO DIN ISO 8015 ACC. TO DIN 16901-140
MATERIAL SEE TABLE	VERARBEITUNGSSPEZ. 114-94010

1 PLC ±0.5	2 PLC ±0.13	3 PLC ±0.013	4 PLC ±0.0001	ANGLES/WINKEL ±2°
FINISH/OBERFLÄCHE/FARBE				

DWN V.Deas	07AUG2009
CHK F.Eltrop	10AUG2009
APVD Ch.Eberwein	11AUG2009
PRODUCT SPEC 108-94214	
APPLICATION SPEC 114-94010	
WEIGHT GEWICHT	11.3g
CUSTOMER DRAWING	/KUNDENZEICHNUNG

		NAME		RESTRICTED TO NUR FÜR
		SLIDE, TAB HOUSING 26POS. Schieber, Flachsteckergehaeuse 26pol.		
SIZE	CAGE CODE	DRAWING NO. ZEICHNUNGS-NR.		
A2	00779	C-2112045		
SCALE MASSSTAB	2:1	SHEET BLATT	1 OF VON 1	REV A4

# Mouser Electronics

Authorized Distributor

Click to View Pricing, Inventory, Delivery & Lifecycle Information:

[TE Connectivity:](#)

[2112045-2](#)