

LOC	DIST	REVISIONS			
P	LTR	DESCRIPTION	DATE	DWN	APVD
B	-	BA	ECO-21-006957	25JUN2021	RK MZ

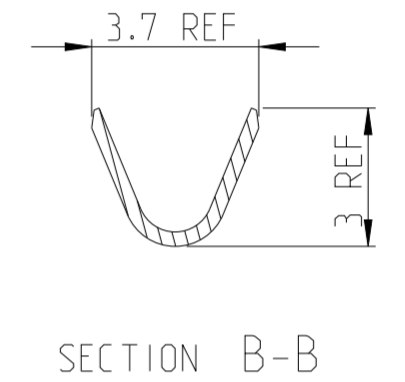

- 1 1.27 MICRON MIN NICKEL PLATE OVER ZONE 3.  
0.76 MICRON MIN PRECIOUS METAL PLATE OVER ZONE 1.  
1 MICRON MIN TIN PLATE OVER ZONE 2.  
CONFORMS TO THE REQUIREMENTS OF TE CONNECTIVITY PRODUCT SPEC 108-10042  
BASED ON EIA/ECA-364-1000.01A (CONTROLLED ENVIRONMENT APPLICATIONS)
- 2 1.27 MICRON MIN NICKEL PLATE OVER ZONE 3.  
0.69 MICRON MIN PRECIOUS METAL PLATE OVER ZONE 1.  
0.076 MICRON MIN GOLD FLASH PLATE OVER THE REMAINDER OF ZONE 3.  
CONFORMS TO THE REQUIREMENTS OF TE CONNECTIVITY PRODUCT SPEC 108-10042  
BASED ON EIA/ECA-364-1000.01A (CONTROLLED ENVIRONMENT APPLICATIONS)
- 3 1.54 - 2.54 MICRON SILVER PLATE OVER ZONE 3.  
0.76 MICRON MIN NICKEL PLATE OVER ZONE 3.
- 4 1.27 MICRON MIN NICKEL PLATE OVER ZONE 3.  
0.76 MICRON MIN GOLD PLATE OVER ZONE 1.  
0.076 MICRON MIN GOLDFLASH PLATE OVER THE REMAINDER OF ZONE 3.
- 5 1.27 MICRON MIN NICKEL PLATE OVER ZONE 3.  
0.76 MICRON MIN GOLD PLATE OVER ZONE 1.  
1 MICRON MIN TIN PLATE OVER ZONE 2.
- 6 HOT-DIPPED PRETIN
- 7 1.27 MICRONS MIN NICKEL PLATE OVER ZONE 3.  
5 MICRON ELECTRO-TIN PLATE OVER ZONE 3.
- 8 0.76 MICRON MIN NICKEL PLATE OVER ZONE 3 PER QQ-N-290  
1.5 - 2.54 MICRON SILVER PLATE OVER ZONE 3.
- 9 SERRATIONS CAN BE MULTILOCK OR TWO SLOTS
- 10. WIRE RANGE: 0.75 - 1.50 mm<sup>2</sup> (18-16 AWG)
- 11. INSULATION RANGE: 2.0 - 2.5 mm (.080-.100) DIA
- 12 SPECIAL REEL WITH 200 PCS FOR REEL-FED HANDTOOL
- 13. OMISSION OF 6 CONTACTS MAX PER REEL OF 5000PCS
- 14 OBSOLETE

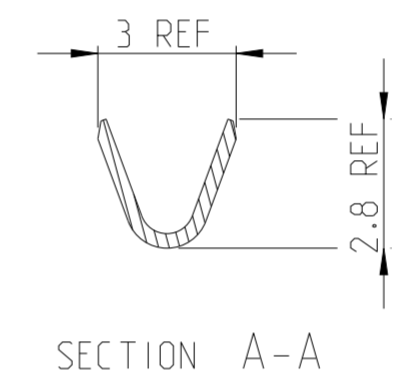
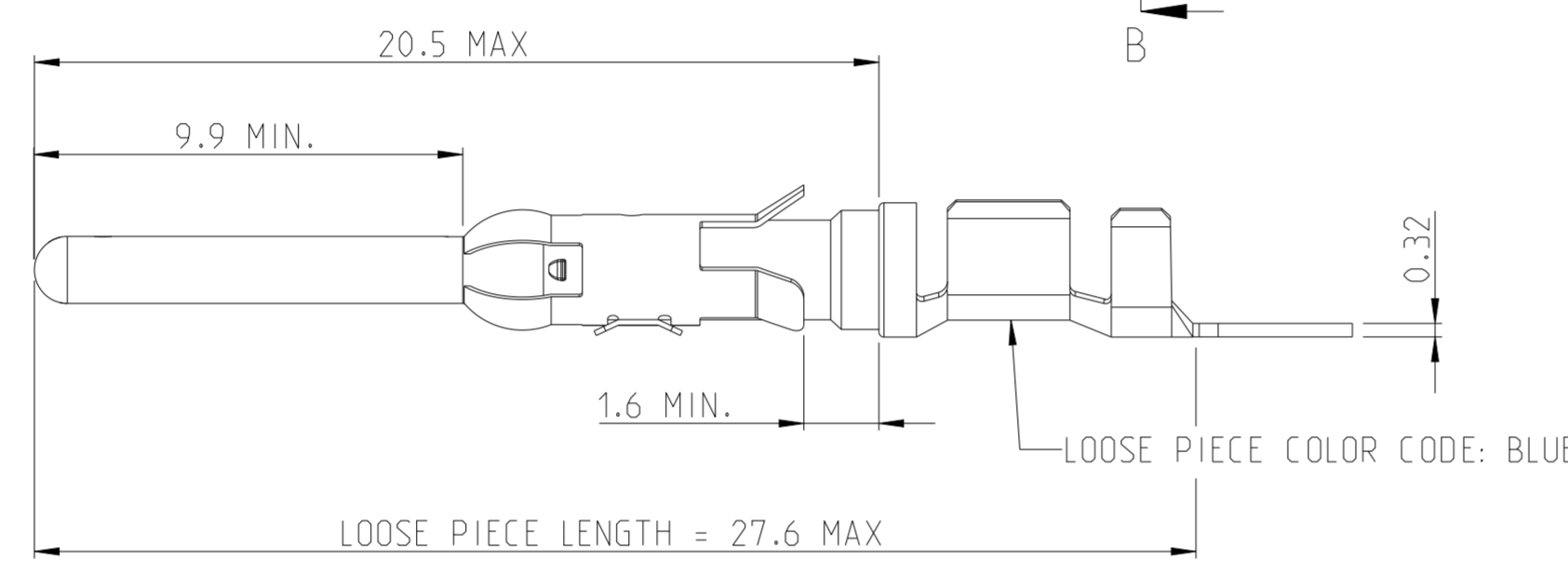
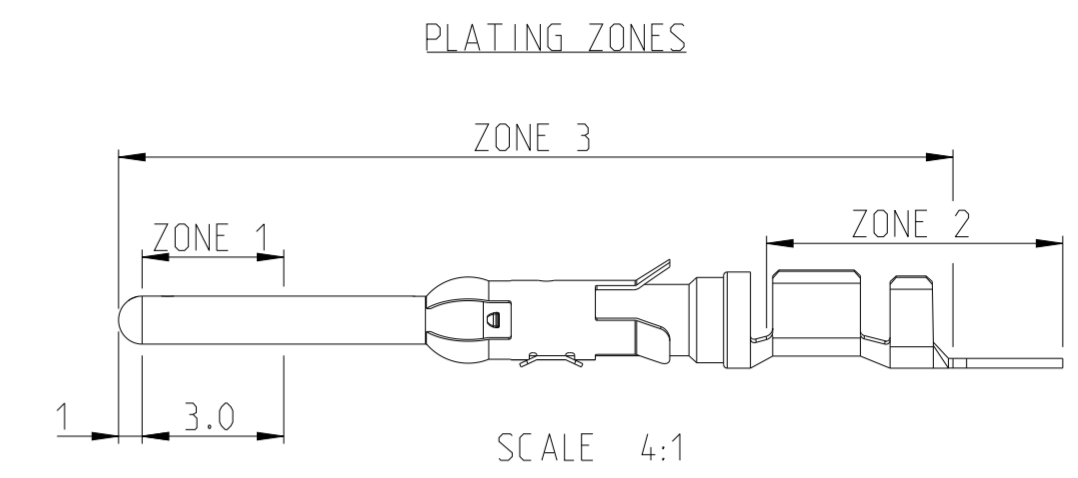
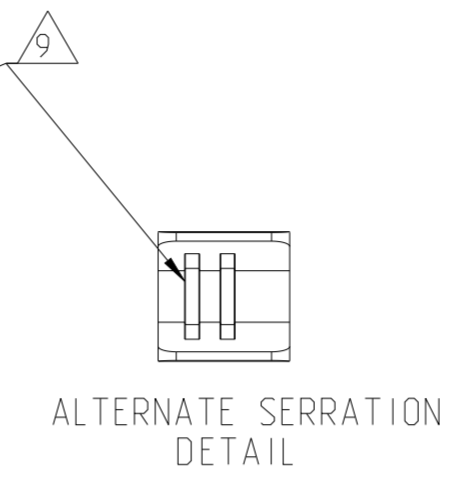
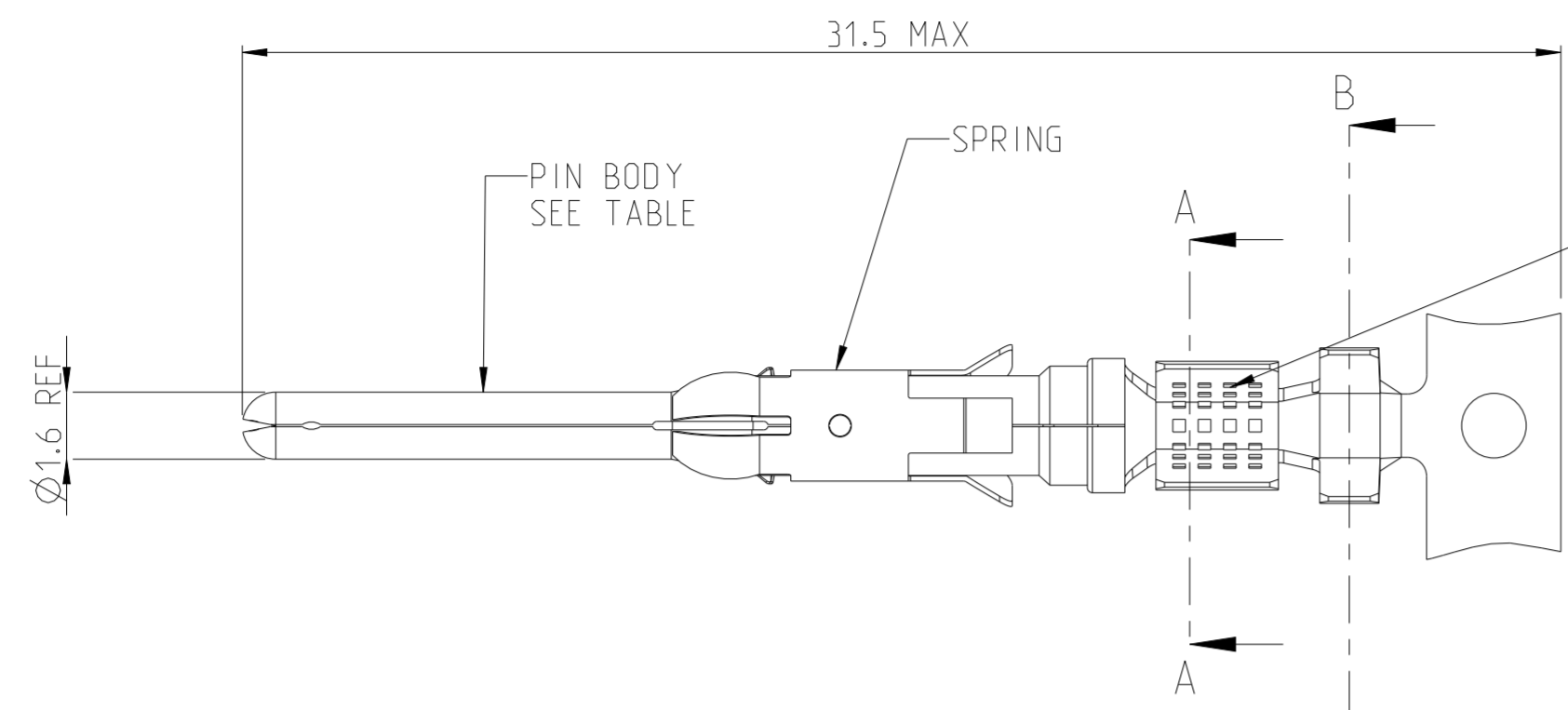
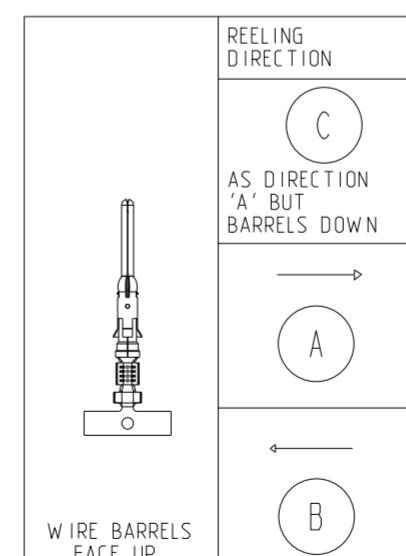

REELING	FINISH	SPRING MATERIAL	PIN BODY	LOOSE PIECE	PART NUMBER
12	7	STAINLESS STEEL	BRASS		5-163081-1
A	3	STAINLESS STEEL	BRASS	1-163082-6	1-163081-7
A	7	STAINLESS STEEL	PH. BRONZE		1-163081-5
B	6	STAINLESS STEEL	PH. BRONZE		1-163081-4
A	6	STAINLESS STEEL	BRASS		1-163081-3
B	6	STAINLESS STEEL	BRASS		1-163081-2
A	1	STAINLESS STEEL	BRASS	1-163082-0	1-163081-1
A	7	STAINLESS STEEL	BRASS	163082-1	163081-8
A	1	STAINLESS STEEL	BRASS	163082-2	163081-7
B	1	STAINLESS STEEL	BRASS		163081-2
B	7	STAINLESS STEEL	BRASS		163081-1

THIS DRAWING IS A CONTROLLED DOCUMENT.

DWN J. BRIGHT 24/10/11  
CHK M. GREENER 24/10/11  
APVD D. PENNINGTON 11/06/12

STE TE Connectivity

NAME TYPE III+, SIZE 16, PIN ASS'Y  
18-16 AWG, 2.0-2.5mm DIA INSULATION

PRODUCT SPEC 108-10042  
APPLICATION SPEC 114-10004

SIZE A2 CAGE CODE 00779 DRAWING NO C-163081 RESTRICTED TO

MATERIAL SEE TABLE TOLERANCES UNLESS OTHERWISE SPECIFIED: SEE TABLE

WEIGHT CUSTOMER DRAWING SCALE NTS SHEET 1 OF 1 REV BA

# Mouser Electronics

Authorized Distributor

Click to View Pricing, Inventory, Delivery & Lifecycle Information:

[TE Connectivity:](#)

[163081-7 \(Cut Strip\)](#)